



STORM|AUDIO

Multi-Channel Power Amplifiers

## Installer Guide

Read Me First...

**PA 8 ELITE**

**PA 8 ULTRA ELITE & MK2**

**PA 16 ELITE & MK2**

If you need  
help...

1. Check the online help of the Web Installer Interface.
2. Check our website support page.
3. Contact our support team:  
**[support@stormaudio.com](mailto:support@stormaudio.com)**

# Welcome

Thank you for choosing a StormAudio Multi-Channel Amplifier. This guide provides step-by-step instructions for setting up your PA ELITE or MK2.

The PA range is based on a common Class D technology delivering high grade performance and sonical quality.

This guide will describe the connectivity of each model.

# What's In the Box

Installer Guide	Multi-Channel Amplifier
Safety Instructions	Power cord *

\* depending on the region, the power cord will be delivered with Fuse to be installed

# Before You Begin

1. In case the AC cord is delivered with Fuses attached, make sure to install them before connecting the unit.
2. Ensure your electrical circuit has a good ground connection with all audio equipment connected to the same ground node to avoid ground loop.
3.  The PA gets cooled down thanks to a regulated FAN control system. With the ELITE versions, 1/2 RU space on sides and free air flow on front and back panel is required. With MK2 versions, 1/2 RU space should be added to the bottom area, air being pulled from the bottom of the front plate.
4. Required equipment:

Multi-Channel Amplifier	XLR cables	Speakers with cables
Audio Processor	Mono Jack 3.5mm cables	LAN router with Cat5/6 RJ45 cable *

\* the PA needs a DHCP server to be part of the network to get an IP address allocated. Make sure to check your Internet Provider box or LAN/Switch box for router function.

# Installation Flow

The installation of the PA shall be made following below steps that will be described along this guide.

<b>1</b>	Audio inputs and control connectivity .....	4
<b>2</b>	Audio outputs connectivity .....	7
<b>3</b>	Trigger control .....	10
<b>4</b>	Power Up and function description .....	11
<b>5</b>	Connectors description .....	14
<b>6</b>	Specifications .....	15

- 1.1) The PA 8 ELITE is made of 2 Master Modules and 2 Slave Modules with the Power Supplies located in the Master Modules. We recommend that most consuming speakers such as LCR and Subwoofers should be connected to the Master Modules, that is to say: Input/Output 1, 2, 5 and 6.
- 1.2) Connect the unit as shown below.

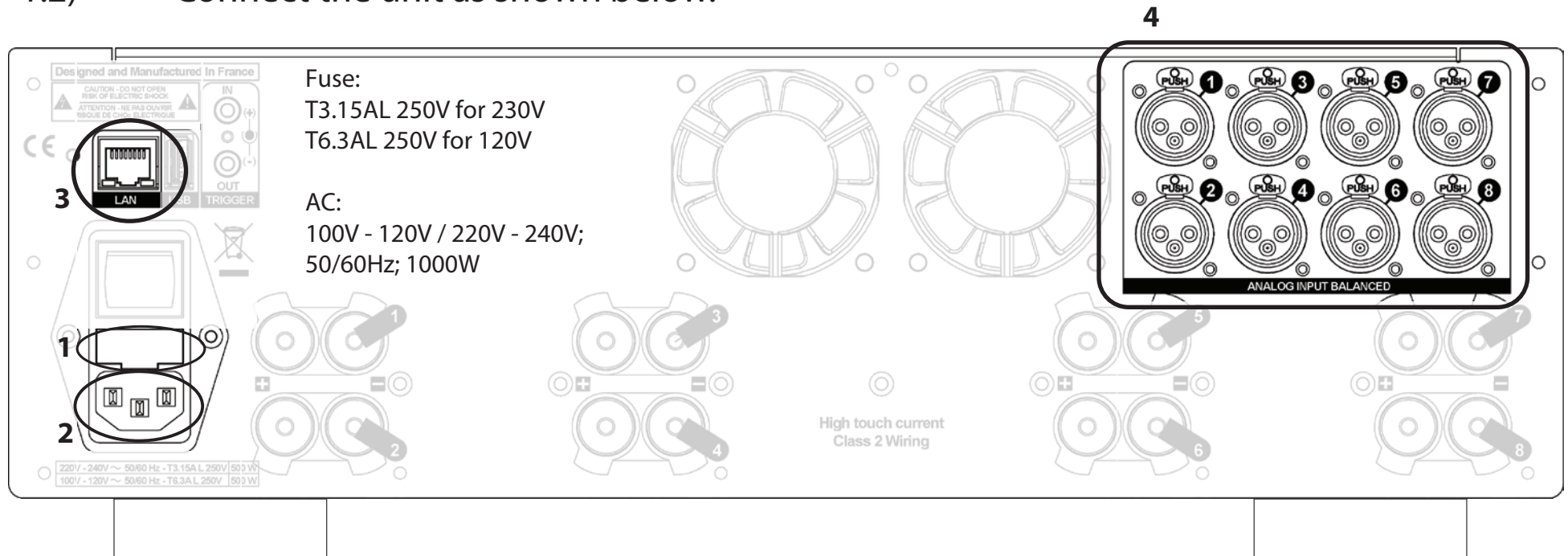

1. Check Fuse and install the proper Fuse if required.
2. Connect AC cord to Power Outlet (do not turn ON now)
3. Connect the RJ45 LAN Network cable to the router/switch
4. Connect your Analog inputs via XLR (see part 5 for connectors description)

- 1.3) The PA 8 ULTRA ELITE or MK2 offers the possibility to provide more power by bridging its outputs. On a per pair basis, you can decide to bridge them.

When Bridging is required, change the position of the Switch (4) to Bridge and make use of the inputs 1, 3, 5 and 7 (shown in orange below).

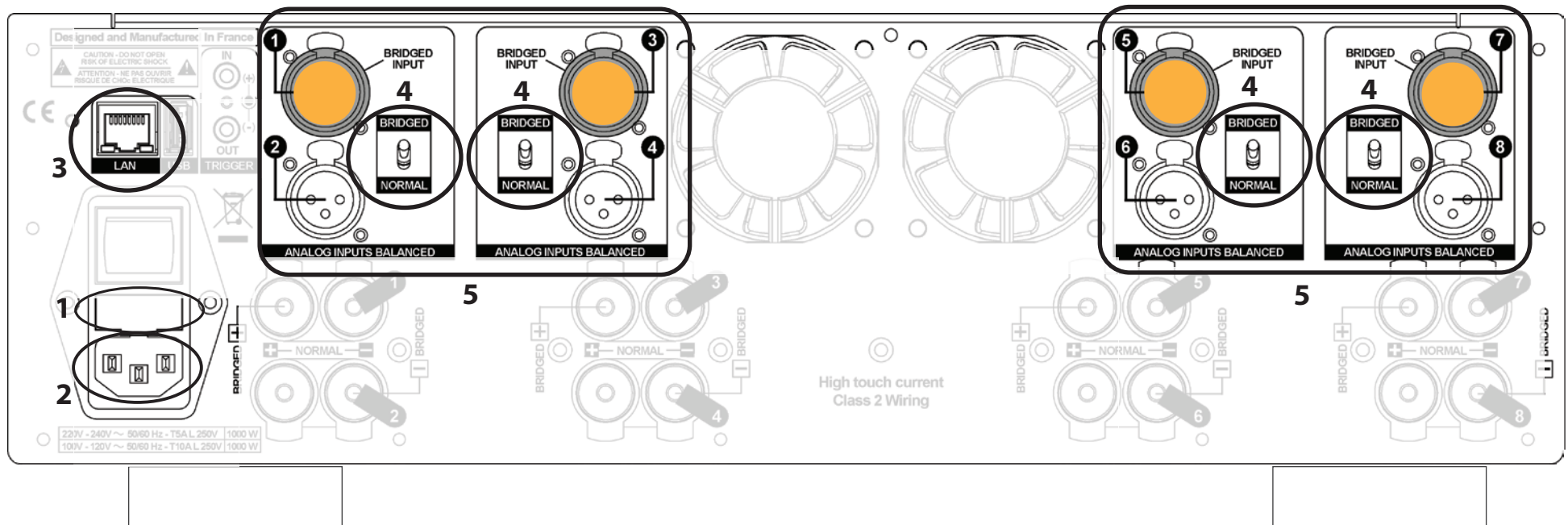

1. Check Fuse and install the proper Fuse if required.
2. Connect AC cord to Power Outlet (do not turn ON now)
3. Connect the RJ45 LAN Network cable to the router/switch
4. Position the switch according to the required output mode: Normal or Bridged
5. Connect your Analog inputs via XLR (see part 5 for connectors description)

1.4) The PA 16 ELITE or MK2 is made of 4 Master Modules and 4 Slave Modules with the Power Supplies located in the Master Modules. We recommend that most consuming speakers such as LCR and Subwoofers should be connected to the Master Modules, that is to say: Input/Output 1, 2, 5, 6, 9, 10, 13 and 14.

1.5) Connect the unit as shown below.

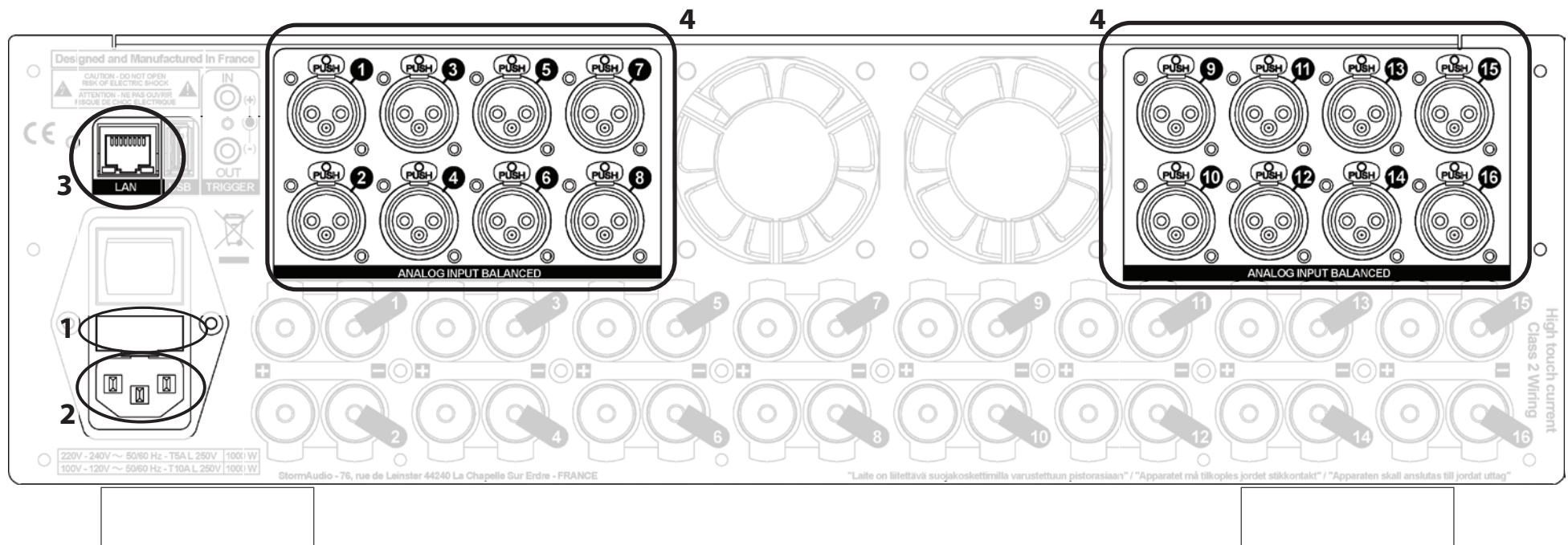

1. Check Fuse and install the proper Fuse if required.
2. Connect AC cord to Power Outlet (do not turn ON now)
3. Connect the RJ45 LAN Network cable to the router/switch
4. Connect your Analog inputs via XLR (see part 5 for connectors description)

- 2.1) Connect the unit as shown below. Make sure to follow the recommendation made on part 1.1 about splitting the most consuming speakers in channels 1, 2, 5 and 6.

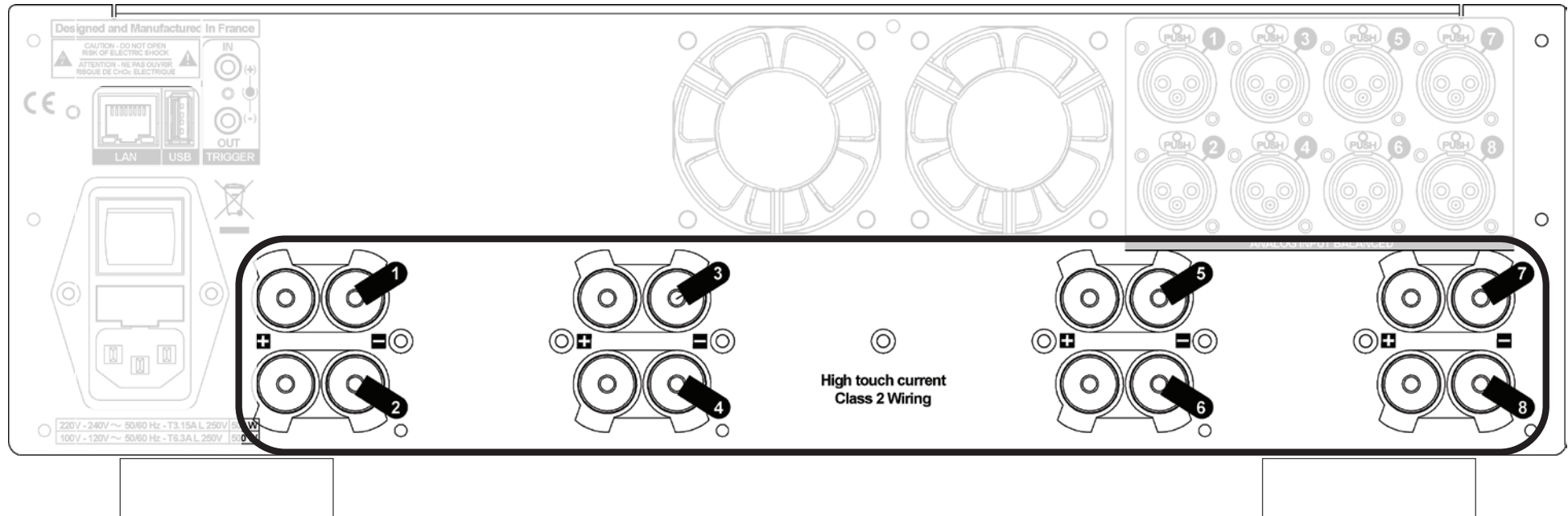

Connect your Analog outputs. We have used high quality binding posts supporting «banana plug», wire up to 4.5mm<sup>2</sup> and fork. The connector is isolated to limit risk of short between outputs.



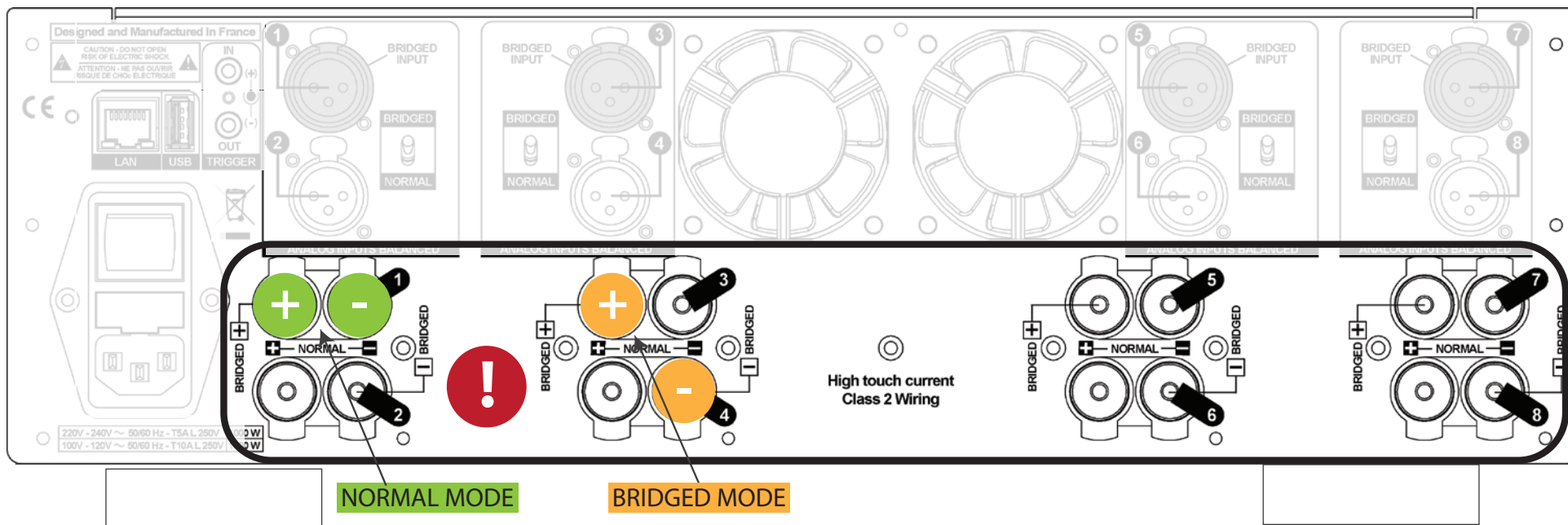

2.2) Connect the unit as shown below.



Connect your Analog outputs.

We warn you to be careful with the connection at this stage. Depending on the Output mode selected in 1.3, you must wire the outputs according to above description:

-  - in green is shown a Normal (Single Ended) connection,
-  - in orange is shown the wiring you must follow for the Bridged mode.

**Note:** when in Bridged mode, the output channel number is the one with the «+» connection. In above illustration, the corresponding input is channel 3.

- 2.3) Connect the unit as shown below. Make sure to follow the recommendation made on part 1.4 about splitting the most consuming speakers in channels 1, 2, 5, 6, 9, 10, 13 and 14.

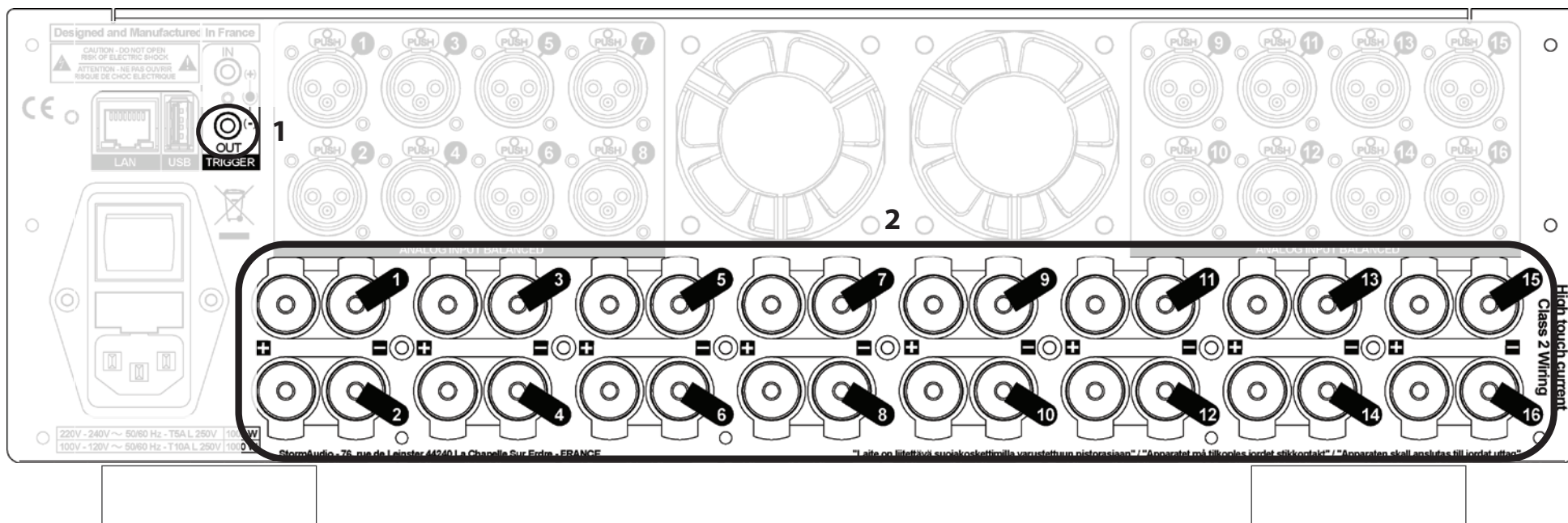

Connect your Analog outputs. We have used high quality binding posts supporting «banana plug», wire up to 4.5mm<sup>2</sup> and fork. The connector is isolated to limit risk of short between outputs.

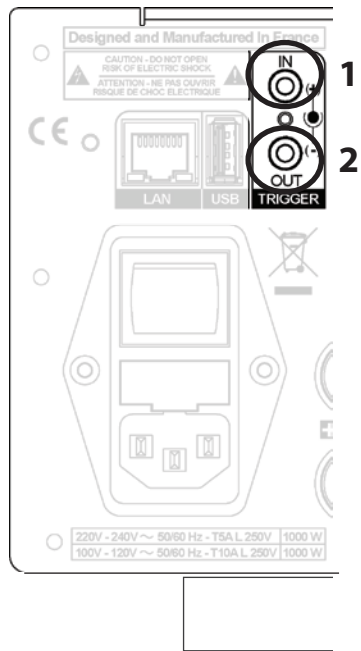

1. The PA can be controlled remotely by the StormAudio ISP (Immersive Sound Processor) or an external controller via its Trigger Input.  
You must setup your controller Trigger output to 12V Active Status. The PA will react to a rising edge to power up.
2. If you need to control several amplifier units, you can daisy chain the Trigger control. It is internally delayed by 2s between Input and Output.

The Trigger interfaces use a standard 3.5mm mono jack connector. A wire as shown herewith is recommended.



## 4.1) Power up sequence.

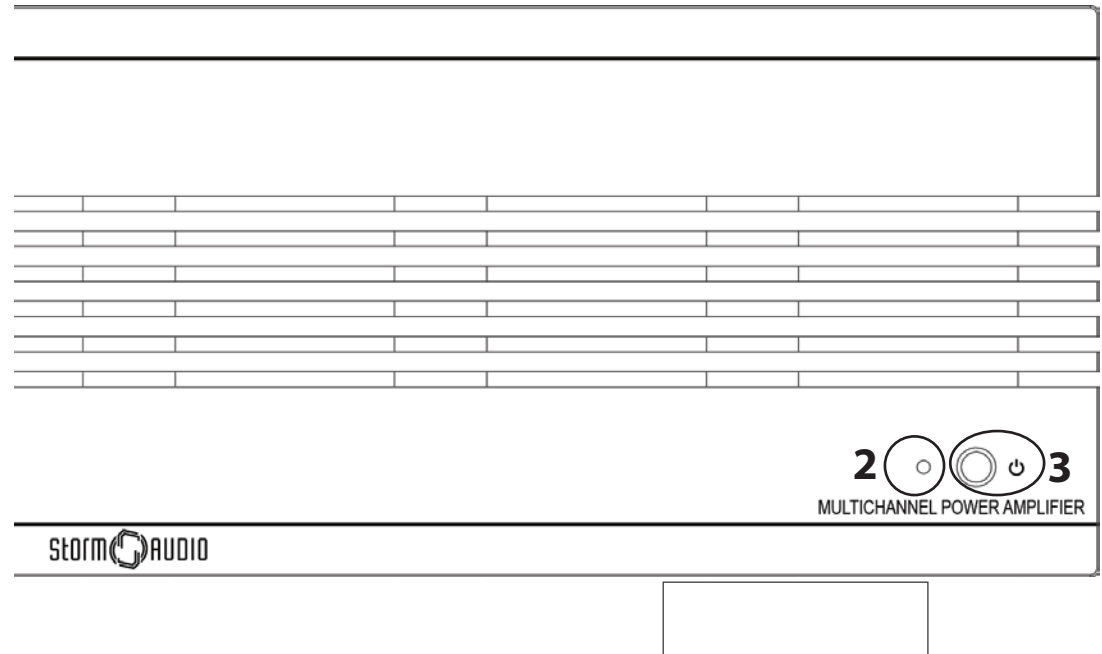
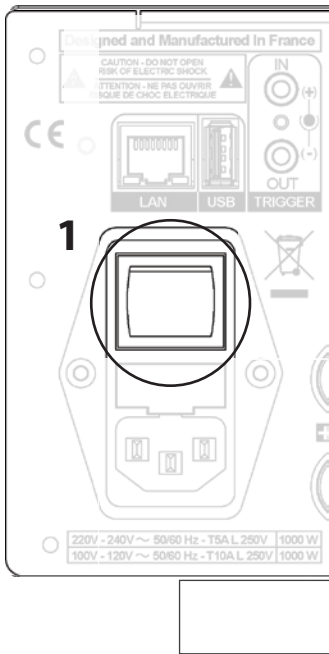

1. Turn the Main Switch to ON (I) on the back panel.
2. Front panel LED will blink red few seconds and will then remain red, unit is in Sleep Mode.
3. When in Sleep Mode, press the Power Button or activate the Trigger in your controller. Unit will start blinking red for a few seconds before turning to green.

- 4.2) The front panel LED is used to indicate statutory informations as well as protection feedback.
- 4.3) The statutory informations are described in the table below :

Unit is in Sleep Mode	In this mode the unit is turned off. It can be activated via the Triggers or the the Network.	RED Fixed
Unit is Initializing	From the Sleep Mode to On Mode and vice versa, the unit has to be initialized and properly turned off. This only lasts for a few seconds with no sound.	RED Blinking
Unit is Upgrading	The PA firmware can be upgraded over the Network. When this occurs, the unit falls in a specific mode with no other activity possible.	GREEN Blinking
Unit is in On Mode	The PA is in its normal playback mode with no failure detected.	GREEN Fixed

- 4.4) The PA range includes a set of protection mechanisms to ensure its best reliability. The system will react to the following event:
- Fan Failure : An active cooling regulation is integrated powered by no less than 6 low noise high speed capable fans. Although extremely reliable over the product's life cycle, we continuously monitor the fans for proper functioning.
  - Overheat : In very extreme conditions such as high power demand in an extreme high temperature environment, the heat dissipation can reach temperatures that can harm the unit if not managed properly.
  - Overcurrent : To prevent shortage at the output that can damage the amplifier stages, the output current is monitored continuously.
  - Overvoltage : Amplifier stages can be damaged in a few occasions. Overvoltage at the power supply level is one of them. To prevent from failure to occur in such event, we are monitoring the supply rails.

- 4.5) The Protection Mechanism is described in the table below.

Unit Overheat	An ambient temperature sensor measures the internal temperature. If $>60^{\circ}\text{C}$ , the unit will go to Sleep Mode. In case PA is controlled via Trigger, unit will restart with $T < 55^{\circ}\text{C}$ .	YELLOW/RED Chaser
Overcurrent / Overvoltage Module malfunction	The unit will MUTE the channels that are showing the problem. This will be released automatically.	YELLOW Blinking
Module Overheat	Each amplifier module is monitored for temperature. The unit will MUTE the channels automatically when threshold is reached. This will be released automatically.	YELLOW/RED Chaser
FAN failure	A FAN failure will not prevent the unit from working correctly. Overheat protection might nevertheless be triggered more easily.	YELLOW Fixed

Special care must be taken of for the cables, wires and connectors to be used with the PA. Here is a description of the connectors pin out and recommendation for the wiring.

- 5.1) To connect the PA to an ISP or a processor, you must use male to female XLR cables. The connector in the ISP is a Female XLR. We recommend cables up to 3m.

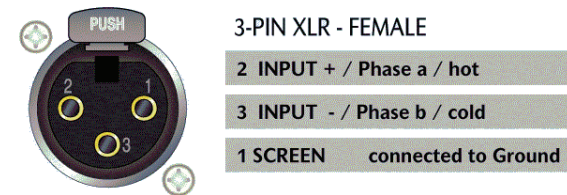

- 5.2) In some cases, it might be required to connect to processors with unbalanced outputs. In such case, the wiring should be done as shown.

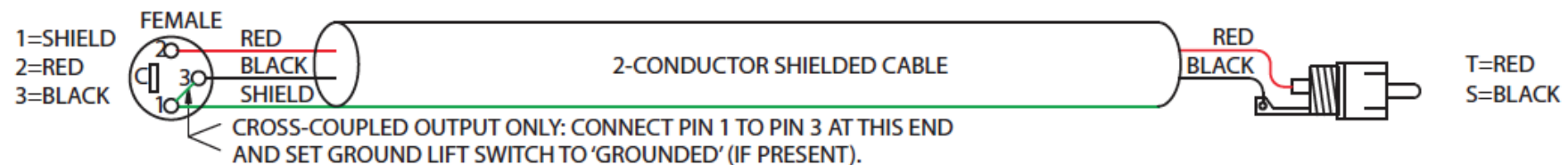

		PA 8 ELITE	PA 16 ELITE & MK2	PA 8 ULTRA ELITE & MK2	
Amplifier Class		Class D	Class D	Class D	
Channel configuration	SE = Single Ended, BTL = Bridged Tied Load	SE - 8	SE - 16	SE - 8 (Normal)	BTL - 4 (Bridged)
Output power 2 channels driven	RMS 8 $\Omega$ : 1 kHz 0.2% distortion	200 W	200 W	200 W	800 W
	RMS 8 $\Omega$ : 1 kHz 1% distortion	250 W	250 W	250 W	1000 W
Output power All channels driven	RMS 8 $\Omega$ : 20 Hz - 20 kHz 0.2% distortion	200 W	200 W	200 W	800 W
Frequency response	High : -3 dB CEM	50 kHz	50 kHz	50 kHz	50 kHz
	Low : -3 dB CEM	10 Hz	10 Hz	10 Hz	10 Hz
Signal / Noise Ratio (A-Weighted)	Referred to P-rated	> 115 dB	> 115 dB	> 115 dB	> 115 dB
THD (20Hz-20kHz), 1 Watt to -1dB max. power		< 0,03%	< 0,03%	< 0,03%	< 0,03%
Gain	Standard	26 dB	26 dB	26 dB	32 dB
Damping factor		> 400	> 400	> 400	
Power Supply	Voltage range	110V to 240V	110V to 240V	110V to 240V	
	Type	SWITCHING MODE	SWITCHING MODE	SWITCHING MODE	
	Range selection	Universal	Universal	Universal	
Casing	Home / Rack (removable ears)	✓	✓	✓	
	Size	3RU	3RU	3RU	

Note: Specifications are subject to change without notice