

ASCENDO

ELEVATE YOUR SOUND

**THE 18-2 SUB
PRO-PASSIVE
SEALED SHALLOW**

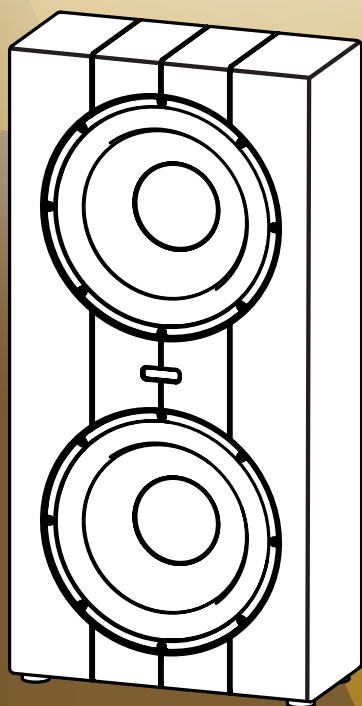

OPERATION MANUAL

THE 18-2 SUB PRO-PASSIVE SEALED SHALLOW

Contents

1 IMPORTANT SAFETY INSTRUCTIONS	2
2 PACKAGE CONTENTS	3
3 PLACEMENT	4
4 CONNECTIONS	5
5 CARING FOR YOUR PRODUCT	6
6 SPECIFICATIONS	6
7 JBL SSW-1 DIMENSIONS.....	7
8 DOCUMENTS / RESOURCES.....	7

IMPORTANT SAFETY INSTRUCTIONS

1. Read these instructions.
2. Keep these instructions.
3. Heed all warnings.
4. Follow all instructions.
5. Clean only with a dry cloth.
6. Install this apparatus in accordance with the manufacturer's instructions.
7. Do not install this apparatus near any heat sources such as radiators, heat registers, stoves or other apparatus.
8. Refer all servicing to qualified service personnel. Servicing is required when the apparatus has been damaged in any way, or the apparatus has been exposed to rain or moisture, does not operate normally or has been dropped.

DISPOSAL

Correct disposal of this product (Waste Electrical & Electronic Equipment) This symbol means the product must not be discarded as household waste and should be delivered to an appropriate collection facility for recycling. Proper disposal and recycling help protect natural resources, human health, and the environment. For more information on disposal and recycling of this product, contact your local municipality, disposal service, or the shop where you bought this product.

RoHS

This product is RoHS compliant. This product is in compliance with Directive 2011/65/EU, and its amendments, on the restriction of the use of certain hazardous substances in electrical and electronic equipment.

REACH

REACH (Regulation No 1907/2006) addresses the production and use of chemical substances and their potential impacts on human health and the environment. Article 33(1) of REACH Regulation requires suppliers to inform the recipients if an article contains more than 0.1 % (per weight per article) of any substance(s) on the Substances of

Very High Concern (SVHC) Candidate List ('REACH candidate list'). At the time of release of this product, no substances of REACH candidate list are contained in a concentration of more than 0.1% per weight in this product.

THANK YOU FOR CHOOSING ASCENDO IMMERSIVE AUDIO.

For more than 23 Years, ASCENDO has been involved in music reproduction. We are confident that the PRO product you have chosen will provide every note of enjoyment that you expect.

Please take a moment to register your product on our website at www.aia-cinema.com. This enables us to keep you posted on our latest advancements and helps us to better understand our customers and build products that meet their needs and expectations. All features and specifications are subject to change without notice.

PACKAGE CONTENTS

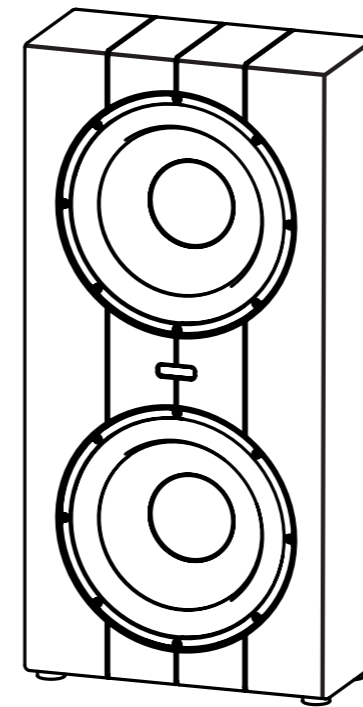

1 x Subwoofer

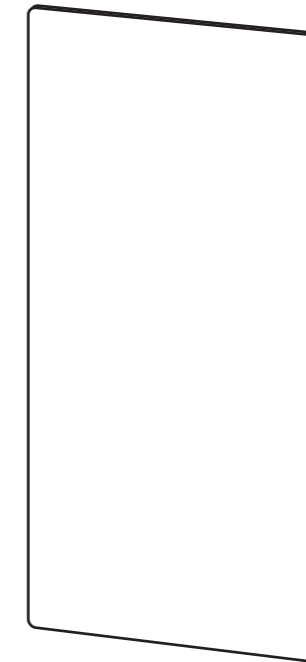

1 x Grille



1 x Quick Start Guide

PLACEMENT

When using subwoofers within the limited confines of a typical home theater room, the boundary reflections, standing waves, and resonant absorbers within the room will create peaks and dips in the bass response that can vary greatly depending on where the listeners are seated in the room. A listener located in one place may hear an overabundance of several bass frequencies created by a response peak at the location, while another listener only a few feet away may hear far less bass at those frequencies but have other peaking or dipping frequencies at that location.

The locations of subwoofers within the room (along with the room's dimensions) also have a profound effect on the creation of these bass response peaks and dips. Careful subwoofer placement alone cannot compensate for all bass response peaks and dips throughout a room, but careful subwoofer placement can eliminate or significantly reduce the largest response dips. It is important to reduce response peaks and dips throughout the room as much as possible via proper subwoofer placement because equalization cannot be used to compensate for large response dips, only peaks. For example, using equalization to restore a 13dB response dip requires that the subwoofer amplifier deliver 20 times the power at that frequency if it solves the problem at all, which it does not in most cases. This can quickly overdrive the subwoofer amplifier into clipping, which will significantly degrade audio quality and reduce the overall output capability. In almost any room, placing the subwoofers in corners will produce the fewest large bass response dips and will also produce the largest bass response peaks. We strongly recommend that you install multiple subwoofers regardless of the room size. A single subwoofer will result in the least consistent bass performance throughout the room. Using multiple subwoofers can reduce some room modes at the various listening locations, resulting in much more consistent low frequency throughout the listening area. It is often impossible to place a single subwoofer in a way that large response dips, which cannot be corrected via equalization, are not present. The use of two or more properly placed subwoofers almost always reduces or eliminates such response dips. Common placement formulas such as placing the subwoofers at 1/4 points rarely work in practice. The best solution is to make high-resolution measurements from the primary listening area while experimenting with speaker placement. Placing a subwoofer at the listening position and measuring it from the potential installation positions around the room – using acoustic reciprocity – can help speed finding the best position(s). Measurement at the best positions in this manner will produce the measurements with the fewest and smallest peaks and dips in the response.

Single Subwoofer

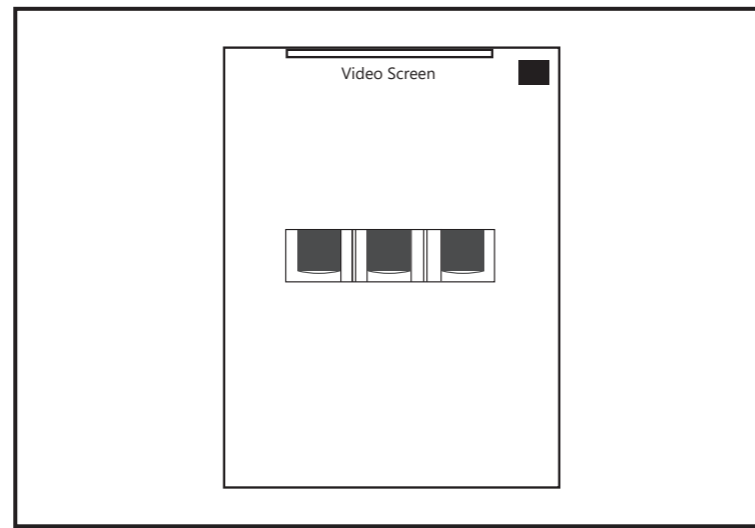

Double Subwoofer

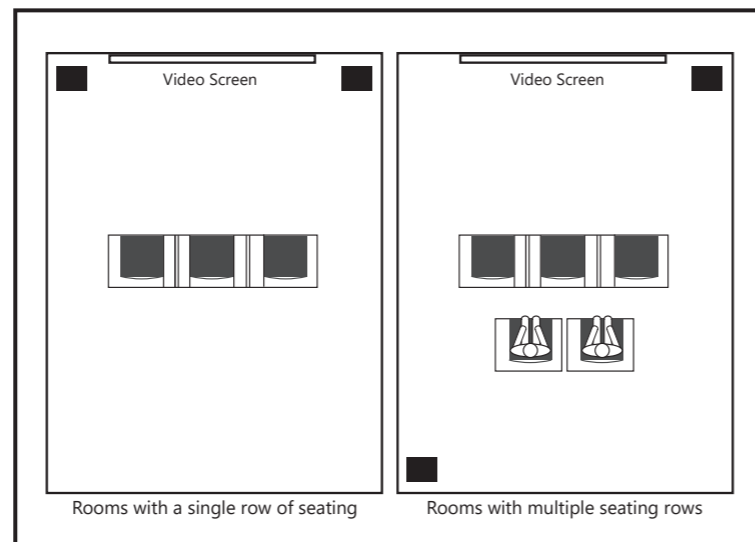

Four Subwoofers

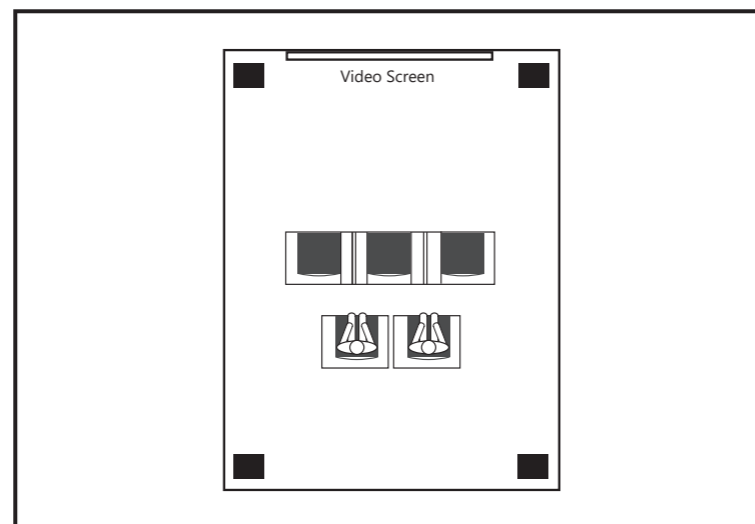

CONNECTIONS

Speakers and electronics have corresponding (+) and (-) terminals. Most manufacturers of speakers and electronics, use red to denote the (+) terminal and black for the (-) terminal. It is important to connect both terminals identically: (+) on the speaker to (+) on the amplifier, and (-) on the speaker to (-) on the amplifier.

This connection ensures, that all speakers work in unison and make a forward movement if a positive signal is applied and move backward when a negative signal is applied.

Wiring "out of phase" results in thin sound, weak bass, and a poor stereo image. With the advent of multichannel surround sound systems, connecting all the speakers in your system with the correct polarity remains equally important to preserve the proper ambience and directionality of the program material.

The AIA "The 18-2 SUB Pro Passive Sealed Shallow" subwoofer has dual inputs, with one input for each woofer. For driving the 18-2 from a single amplifier channel, the (+) terminal of the amplifier should connect to both (+) input terminals of the The 18-2. The (-) terminal of the amplifier should be connected to both (-) terminals. (Figure 2) In this wiring configuration, the amplifier will be presented with a 2 Ohm load. Alternatively, (Figure 1) two equal amplifier channels can be used, one for each woofer.

Each amplifier (+) terminal should connect to one of the woofer input (+) terminals. Each amplifier (-) terminal should connect to the (-) terminal of the terminal set that is connected to the same amplifier channel's (+) terminal.

If the bass response seems low, there may be a polarity or phase problem between the two drivers, with the sound waves from the two woofers canceling each other out. Double-check your wiring and DSP settings to make sure both woofers in a single 18-2 have their (+) terminal connected to the appropriate amplifier (+) terminal and their (-) terminal connected to the appropriate amplifier (-) terminal.

If two 18-2 subwoofers are used, the wires for both speakers should be similar in length. If the bass response seems low, there may be a phase problem between the subwoofers, with the sound waves from the two subwoofers canceling each other out. If the bass response seems low, check the correct polarity of all wiring including Speaker wires, XLR signal cables, DSP settings etc.

To use the speaker terminals on the terminal cup located behind the 18-2 unplug the phoenix connector for easier termination. Insert the bare end of the wires making sure to observe the correct polarity. The wire from the amplifier's negative (-) terminal is to be connected to the negative (-) terminal on the terminal cup, and the amplifier's positive (+) terminal is to be connected the positive (+) terminal on the terminal cup.

The 18-2 subwoofer is specifically designed for use in conjunction with the AIA DSP amplifiers. It is optimized to offer the best dynamics and frequency response which is specially designed to use the proprietary 18-2 tuning file. When using a different amplifier with the 18-2, contact your certified AIA installer or calibrator for correct adjustment and loading of the tuning file. Connect your main receiver or processor's LFE subwoofer output to the line-level input on your subwoofer amplifier. When using two or more subwoofers, use the correct number of amplifier channels (these can be mono or multi-channel amplifiers) each connected to the appropriate output on your processor or receiver. Then connect the positive and negative terminals for each amplifier channel to a single 18-2 subwoofer system.

USING ONE The 18-2 SUB Pro Passive Sealed Shallow SUBWOOFER WITH TWO AMPLIFIER CHANNELS

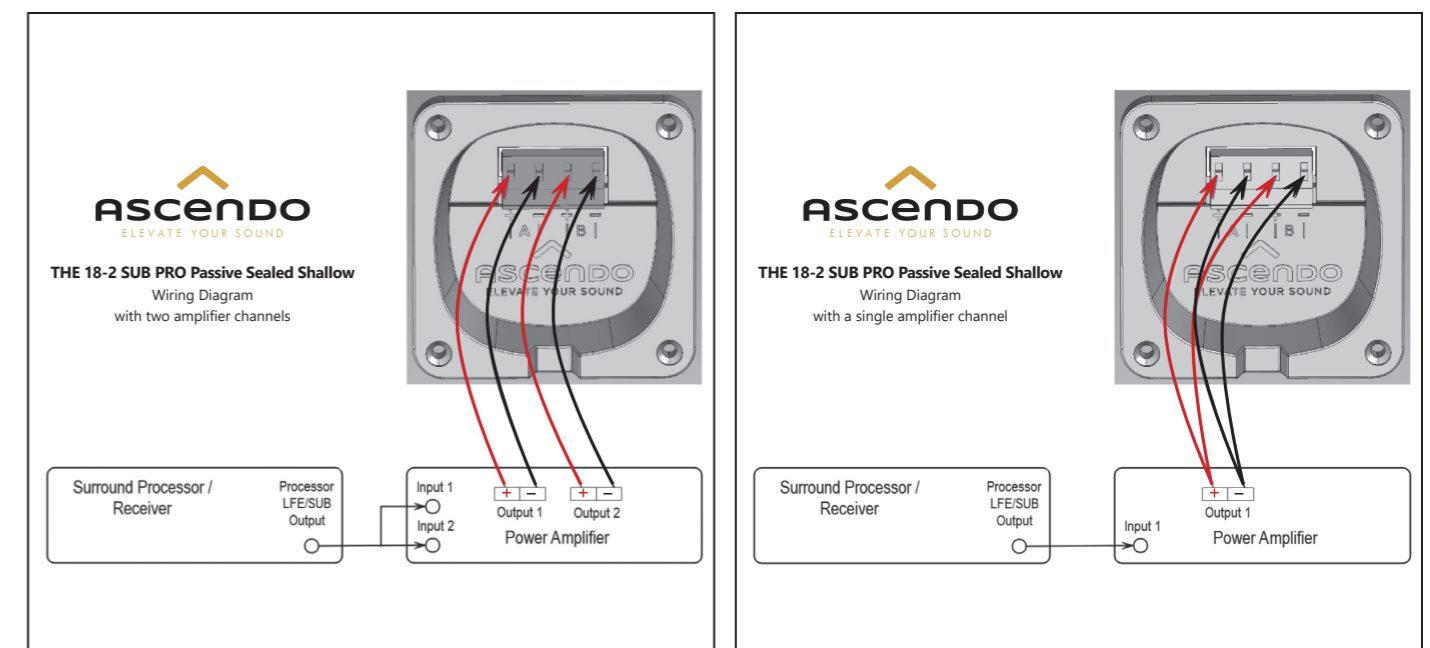

CARING FOR YOUR PRODUCT

Wipe the cabinet with a clean, dry cloth to remove dust. A damp cloth may dull the cabinet's finish. Do not use volatile liquids such as benzene, paint thinner or alcohol on the cabinet.

Do not spray insecticide near the cabinet.

To remove dust from the grille fabric, use a vacuum cleaner, soft brush and set to low suction.

Do not wash the grille in water, as water may fade the grille's color or make it uneven.

If the surface of the woofer cone becomes dusty you can carefully sweep it clean with a soft, dry calligraphy brush or paint brush or low air pressure. Do not use a damp cloth.

SPECIFICATIONS

Modell	The18-2 SUB PRO PASSIVE SEALED SHALLOW
Speaker type	2 x 18" forward-firing, advanced carbon rohacell composite sandwich cones, neodymium motor with 4" ultra-high-temperature Voice-coil
Xmax	23mm excursion each direction (46 mm linear) voice coil remain ing in homogeneous magnetic field, linear and lowest distortion
Passive Active	Passive
Recommended amplifiers	1Ch DSP + 1 or 2Ch Amplifier are required. Min. recommended amplifier: 89 Vrms, 126 Vpk, 45 A; equivalent to4000W@4Ohms, with correct RMS & Peak limiting & compression settings
Recommended ASCENDO amplifiers	(With additional external 1CH DSP: AIA2-6004), DSP4-10K2
Enclosure design	Sealed
SPL (Peak / half space 2pi)	Measured Data, 138 dB @ 63 Hz peak and up, 120 dB @23 Hz
Frequency Range	Measurement Data (without ext. DSP) 33 Hz - 400 Hz / -3 dB 23 Hz - 500 Hz / -15 dB
Sensitivity	89 dB / 1W/m 4 pi, 93dB / 1W/m 2 pi
Power handling	5000 W
Impedance	4 Ω per woofer
Air volume displacement	5,32 L / in comparison 18" standard cinema subwoofer 1,1 L
Directivity horizontal x vertical in Deg°	360°
Input Terminal	4-conductor Phoenix 12 AWG (3,3 mm ²) screw clamp push on binding post
Enclousure	Internally braced birch ply
Dimensions (W/H/D) mm	600 / 1215 / 265 (with grille 292,5) Vertical 1200 / 615 / 265 (with grille 292,5) Horizontal
Dimensions (W/H/D) inch	23,62 / 47,83 / 10,43 (with grille 11,52) Vertical 47,24 / 24,21 / 10,43 (with grille 11,52) Horizontal
Packing dimensions (W/H/D) mm	740 / 1340 / 430
Packing dimensions (W/H/D) inch	29,13 / 52,75 / 16,92
Weight	67 kg / 147,71 lbs
Gross weight	78,2 kg / 172,40 lbs
Finish	satın matte black

Technical modifications subject to change without further notice

DIMENSIONS

The 18-2 SUB PRO PASSIVE SEALED Shallow

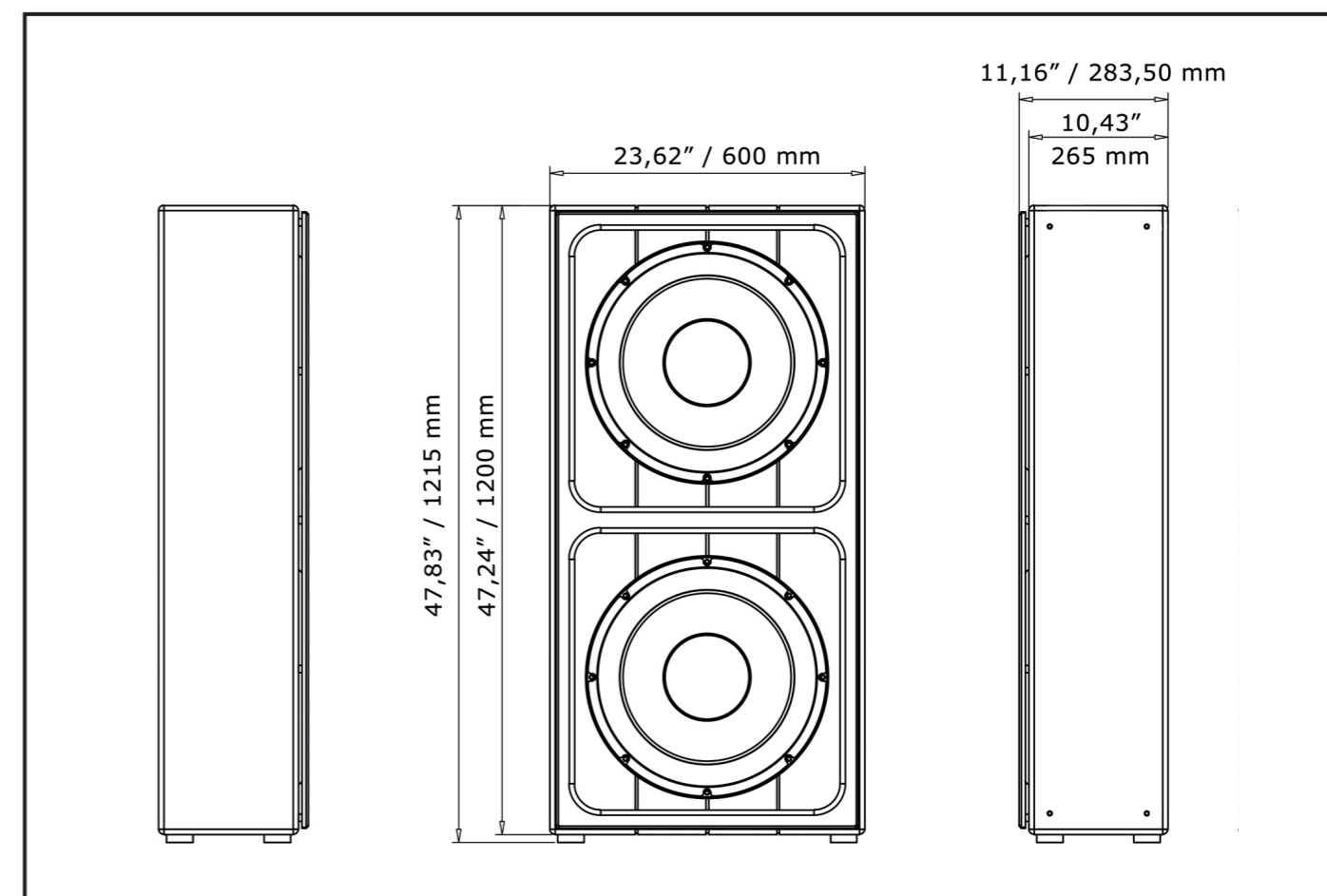

DOCUMENTS / RESOURCES

ASCENDO_The 18-2 SUB PRO PASSIVE SEALED Shallow (pdf)



ASCENDO
ELEVATE YOUR SOUND



CE

ASCENDO Immersive Audio GmbH

Adlerstrasse 2, Gebäude C, EG

D-91560 Heilsbronn · Germany

Tel.: +49 9872-9 537 157 · www.aia-cinema.com

