

8" 2-WAY INVISIBLE IN-WALL OR IN-CEILING LOUDSPEAKER

Recommended Applications:

- Multi-Room Audio Systems
- Foreground Music
- Background Music
- Voice Paging
- Home Theater / Surround Sound
- Sound Masking Systems

Recommended Installations:

Flush mounted in walls or ceilings constructed of wood or steel framing with 1/2" (12.7 mm) or thicker gypsum wallboard. Minimum 2-1/2" (63.5 mm) cavity depth required.

Performance:

- 120 Watts RMS
- 45Hz to 20kHz (see Figure 1)
- 60W Minimum recommended power

Protection:

Two independent self-resetting circuits (low and high-frequency).

On-Site Finish Options:

Finish options include latex paint, flat finish, orange peel texture, light plaster, light wallpaper, light fabric, wood veneer, and other selected approved finishes.



Front view

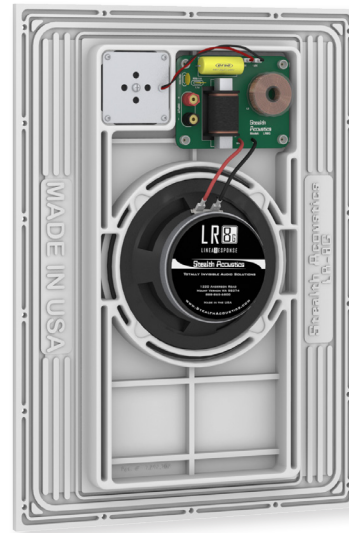

Rear view

LINEAR RESPONSE

INVISIBLE SPEAKERS

The Stealth Acoustics model LR8G is a two-way, full-range loudspeaker system that becomes completely invisible after installation. The loudspeaker has a rigid frame that attaches directly to standard structural framing. The paintable active diaphragm face is bonded to the frame of the speaker panel, creating an active area surrounded by a stable mounting area. Installation instructions are shown on a paper overlay that is to be removed before installation. The overlay can also be used as a cutting template for retrofitting the speakers into existing wallboard.

The LR8G may be installed in either the wall or ceiling and on-site finishing options include latex paint, light wallpaper, fabrics and selected texture coats. There is no need for nonstandard wallboard finishing materials. Advanced finishing methods such as veneer treatments may be supported using special techniques.

The Stealth Acoustics LR8G incorporates an acoustically coupled high quality low profile, high-power 8" cone woofer and a direct coupled 25 mm neo-magnet high-frequency motor. Advanced internal materials allow for smooth frequency extension to 20 kHz. When the LR8G is installed in the recommended backbox, frequency response below 45 Hz can be achieved. The LR8G contains two independent protection circuits (high-frequency and low-frequency sections) that automatically reset upon reduction of excessive amplifier power.

For proper registration, each speaker must be installed so that the surface of the **perimeter edge is flush** with the adjoining wallboard. When correctly in place, the surface of the speaker **face panel extends above** the height of the wallboard by 1/16" (1.6 mm). This is done to allow space for the tape and joint

compound needed to blend the panel into the wall. Shims are included to allow for mounting in wallboard thicker than 1/2" (12.7 mm).

Stealth Acoustics' invisibility offers a powerful advantage over traditional loudspeakers because they can be placed wherever they sound best, free of visual concerns that may conflict with architectural features. Accompanying the full range panels, Stealth Acoustics offers the B22G and the B30G – completely invisible companion subwoofers for extended low frequency response.

All Stealth Acoustics products are covered by a 5 year manufacturer's warranty as well as an optional 15 year extended warranty. The LR8G also has 100, 70 and 25 volt constant voltage transformers available as factory installed options.



8" 2-WAY INVISIBLE IN-WALL OR IN-CEILING LOUDSPEAKER

Architectural & Engineering Specifications

The loudspeaker shall be a two-way, full-range device, producing frequencies from 45Hz to 20kHz. The total radiating surface shall be 352 sq. in (2,271 sq. cm) and high frequency dispersion shall be a nominal 170 degrees in both horizontal and vertical planes. The loudspeaker system shall have a sensitivity of 83 dB, 1 watt / 1 meter, with a capacity of 120 watts RMS according to EIA standard RS-426-A. The loudspeaker shall have two independent self-resetting protection devices, one each for the high-frequency driver and the low-frequency driver.

The loudspeaker shall fit into walls and ceilings with wood or steel stud construction offering a minimum of 2-1/2" (63.5 mm) depth cavity. The loudspeaker shall mount directly to the structural framing and have the capability of seamlessly adjoining 1/2" (12.7 mm) or thicker gypsum wallboard. The minimum distance between framing members shall be 9-1/2" (241 mm). Face panel finishing methods shall be consistent with normal gypsum wallboard finishing techniques and may include latex paint, light wallpaper, light fabric, wood veneer and other selected approved finishes as specified.

The loudspeaker shall be the Stealth Acoustics Model LR8G and shall carry a 5 year manufacturer's warranty.

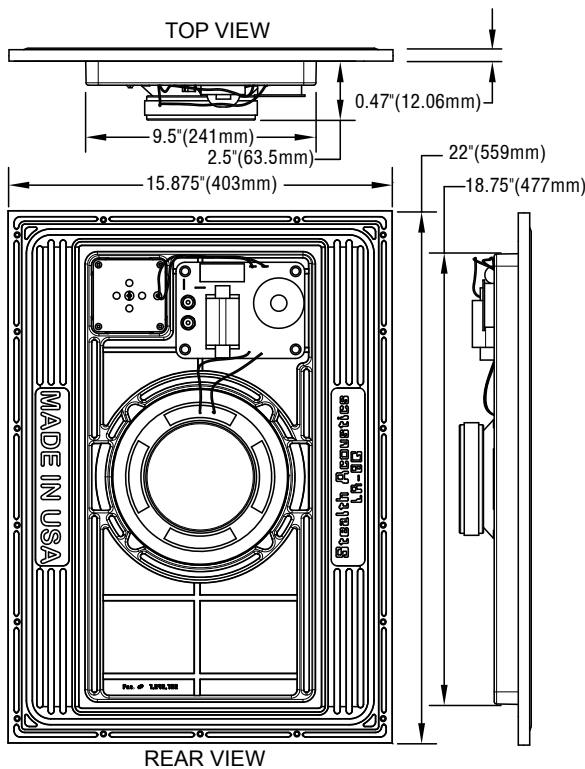

Product Specifications

Frequency Response:

45Hz to 20kHz (see Figure 1)

Power Capacity:

120 watts RMS
60 watts minimum recommended power

Protection:

Two independent self-resetting devices (low and high frequency)

Sensitivity:

83 dB (1 watt / 1 meter)

Driver Components:

High frequency: 1" (25 mm) neodymium motor
Low-frequency: 1" (25 mm) voice coil, 8" (203 mm) woofer
Ceramic 20 oz. (622 gr) magnet

System Impedance:

8Ω nominal

Polar Dispersion:

170 degrees vertical and horizontal

Dimensions:

Width: 15-7/8" (403 mm)
Height: 22" (559 mm)
Mounting Depth: 2-1/2" (63.5 mm)

Product Weight:

14 lbs. (6.3 kg)

Shipping Weight:

32 lbs. (14.5 kg) per pair
20 lbs. (9 kg) per single

Included Accessories:

Mounting shims
Mounting screws
Terminal wrench

Optional Accessories:

PS-22 PlaceSaver™
BX-22 MDF Acoustic Back Box
MBX-22 UL Listed Metal Back Box
MBA-22 UL Listed Metal Back Box - Adjustable
MBC-22 Concrete Back Box
SK-1 Shim Kit
CVXMR 100, 75 and 25 volt Constant Voltage Xfmr
WARRANTY Extended Warranty - 15 year

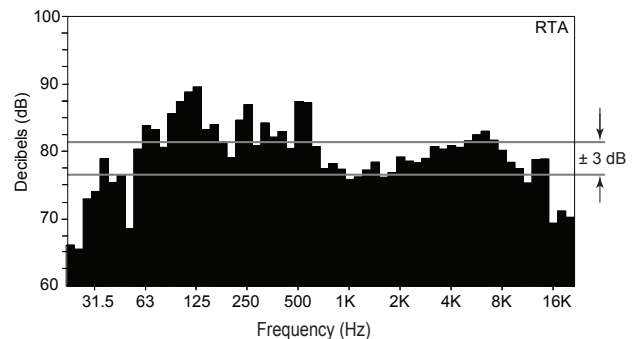

Figure 1: On-axis frequency response in standard stud wall with four coats of latex paint applied to the speaker face panel.