



SM-CS-ART2-L
SM-CS-ART2-XL
Strong™ Contractor Series
Universal Articulating Mount With Dual Arms



INSTALLATION MANUAL



WARNING

The maximum weight of this wall mount is 150 lbs (68.04 kg). Use with heavier than the maximum weight indicated may result in instability causing possible injury.

Ensure these instructions are thoroughly understood before attempting installation. If unsure of any part of the installation process, contact a professional installer for assistance.

The wall or mounting surface must be capable of supporting the combined weight of the mount and the display; otherwise the structure must be reinforced. Installer is responsible for verifying the wall/mounting surface and the anchors used can support the total load of the installation.

Safety gear and proper tools must be used. Failure to do so can result in property damage and/or serious injury.

A minimum of two people is required for this installation and it is highly recommended that this product be installed by qualified professionals.

Follow all instructions and recommendations regarding suitable locations for display installation. Consult the display equipment's documentation for information relative to its requirements.

NOTE: This mount supports display mounting from VESA 200x100, 200x200, up to 600x400.

SPECIFICATIONS

- Maximum Load: 150 lbs (68.04 kg)
- Maximum Extension: 30-5/8"
- Wire Management
- Pan/Swivel Range: 180°
- Tilt Range: -5° /+ 15°











BOX CONTENTS

- Wall Arm Assembly (1)
- Adapter Bracket (2)
- Adapter Panel (1)
- Hardware Kit (1)
- Wire Covers (6)
- Template (1)

TOOLS REQUIRED

- Power Drill
- 1/4" & 5/16" Drill Bits
- Level
- 1/2" (13mm) Wrench
- Hammer
- Stud Finder
- Phillips Screw Driver

HARDWARE

IMAGE	DESCRIPTION	ITEM	QUANTITY
BAG 1			
	Phillips Head Bolt	(A) M4x10 (B) M4x20 (C) M4x30 (D) M4x40 (E) M5x10 (F) M5x20 (G) M5x30 (H) M5x40 (I) M6x10 (J) M6x20 (K) M6x30 (L) M6x40 (M) M8x10 (N) M8x20 (O) M8x30 (P) M8x40	4 of each size
	Flat Washer	(Q) M5 (R) M8	16 8
	Nylon Spacer	(S) M4/M5 (T) M6/M8	8 8
	Square Washer	(U) 36.2x2.5mm	4
	Recessed Hole Spacer	(V) Recessed Hole Spacer	4
	Spacer	(W) Spacer	4
BAG 2			
	Lag Bolt	(X) M8x65 Bolt	6
	Anchor	(Y) Concrete Anchor	6
	Lag Bolt Washer	(Z) Flat Washer	6
	Phillips Head Flange Bolt	(AA) M6x12	4
	Button Head Flange Bolt	(BB) M8x12	4
	Allen Key		1

INSTALLATION

Layout and Drilling

1. Determine general location of the display.
2. Use a stud finder to find the nearest wall studs if applicable and mark their location.
3. Tape template flat and level to wall surface, aligning the template's slots with the stud markings on the wall.

NOTE: Use of a bead level is recommended.

NOTE: Template corners fold up to catch debris.

4. Use a pen or pointed object to mark bore locations.

ATTENTION: Before drilling, verify there is a minimum of 1-3/8" of concrete thickness to be used for the concrete anchors. Ensure to mount in a solid part of the block, generally 1" minimum from the side of the block. Cinder block must meet ASTM C-90 specifications.

ATTENTION: Concrete must be 2000 psi density minimum. Lighter density concrete may not hold concrete anchor.

ATTENTION: A standard electric drill on slow setting should be used to drill the holes instead of a hammer drill to avoid breaking out the back of the hole when entering a void or cavity.

5. Drill holes (Figure 1):

- Use 1/4" bit for drilling into wooden studs (x4).
- Use 5/16" bit for drilling into concrete wall (x6).

NOTE: Two additional holes and provided anchors are needed for concrete installs.

ATTENTION: Be sure to drill holes centered within studs. Do not drill into mortar joints.

Wall Mounting of Arm Assembly

1. Hammer concrete anchors (Y) into wall as applicable (Figure 1).
2. Apply washers (Z) to lag bolts (X).
3. Hold Arm Assembly in place while applying lag bolts (X) with washers (Z).

NOTE: A properly mounted Arm Assembly will be oriented so that its Keyed Notches side of the Arm Assembly Head Mount is upward.

4. Tighten bolts snugly without overtightening.

CAUTION: Overtightening can damage the bolts and reduce their holding strength. Refer to the mounting template for specifics.

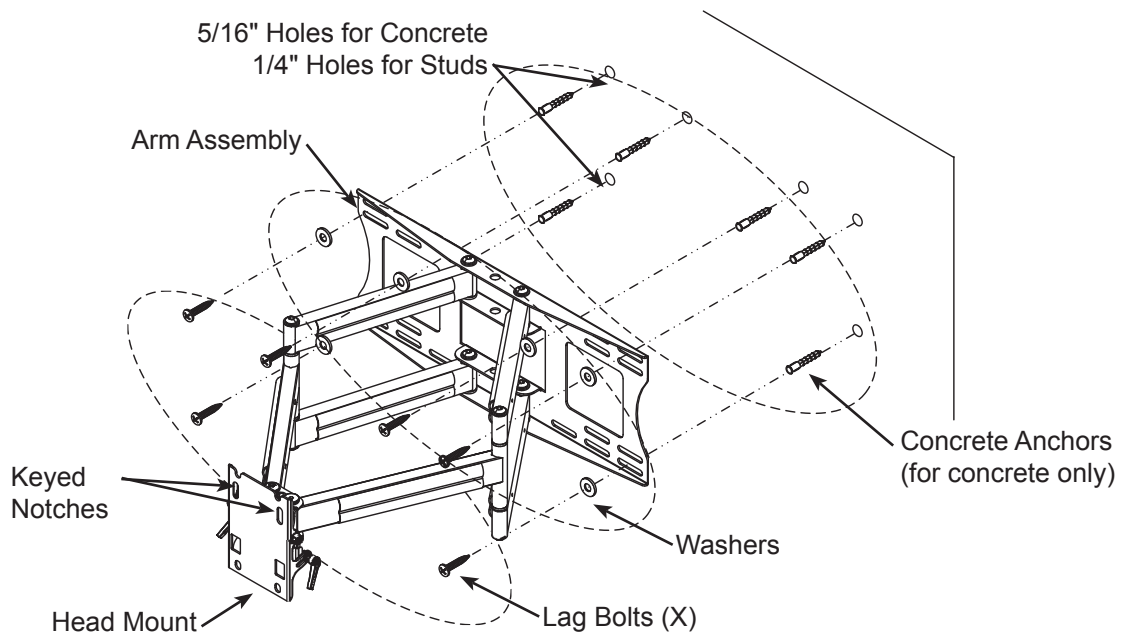

Assemble Display Bracket

1. Slide the Adapter Brackets onto each end of the Adapter Rods (Figure 2).

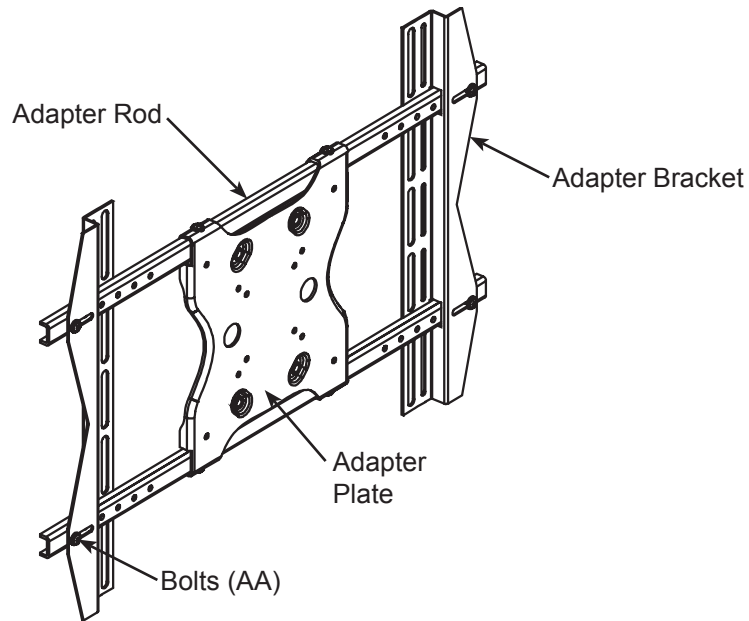

Figure 2

Mount Display Bracket to Display Panel

1. Place the assembled Display Bracket on the back of the display with one Adapter Bracket aligned with a set of vertical mounting holes (Figure 3).
2. Slide the other Adapter Bracket in or out until it aligns with the second set of vertical mounting holes.
NOTE: The Adapter Plate should be horizontally centered on the back of the flat panel display.
NOTE: There are eight positions for flexibility. Move the Adapter Brackets to desired location. Adapter Brackets can be flipped around (if required).
3. Tighten Adapter Brackets to Adapter Rods using four bolts (AA) with a Phillips Head Screw Driver.
4. Attach the Adapter Brackets using four mounting bolts (A - P) and four square washers (U).
NOTE: Bolt size will depend on thread pattern on flat panel being installed.
5. Once aligned, tighten all screws down with a Phillips Head Screw Driver.

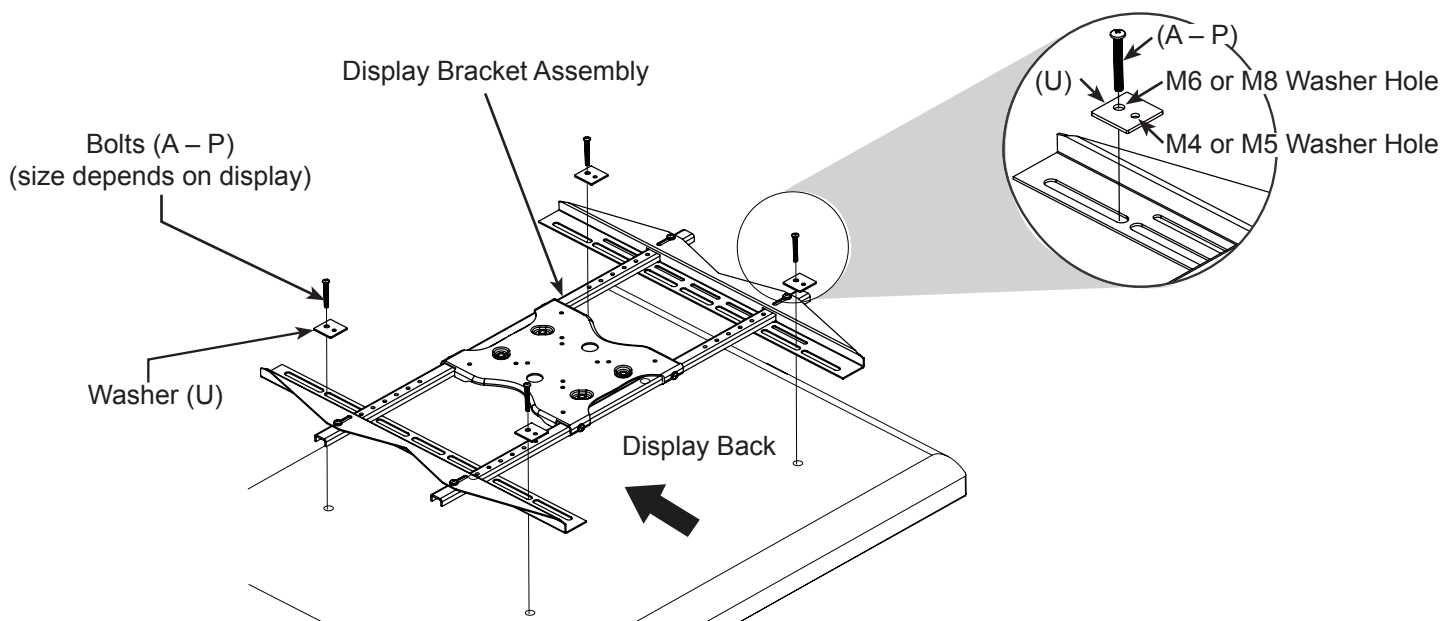

Figure 3

Attach Screen to Arm Assembly

1. Insert two bolts (BB) into top two holes of Adapter Plate. Leave approximately 1/4" of exposed thread (do not fully tighten).
2. Lift the display and hook the two bolts (BB) in grooves on top of the Mounting Head (Figure 4).
3. Insert two bolts (BB) in bottom two holes of the Mounting Head, securing it to the Adapter Plate.
4. Then tighten all four bolts with the Allen Key.

NOTE: For demonstration purposes, the wall has been omitted from the illustrations.

ATTENTION: This procedure requires two persons. Ensure that the arm is set to its maximum negative tilt prior to attaching the display.

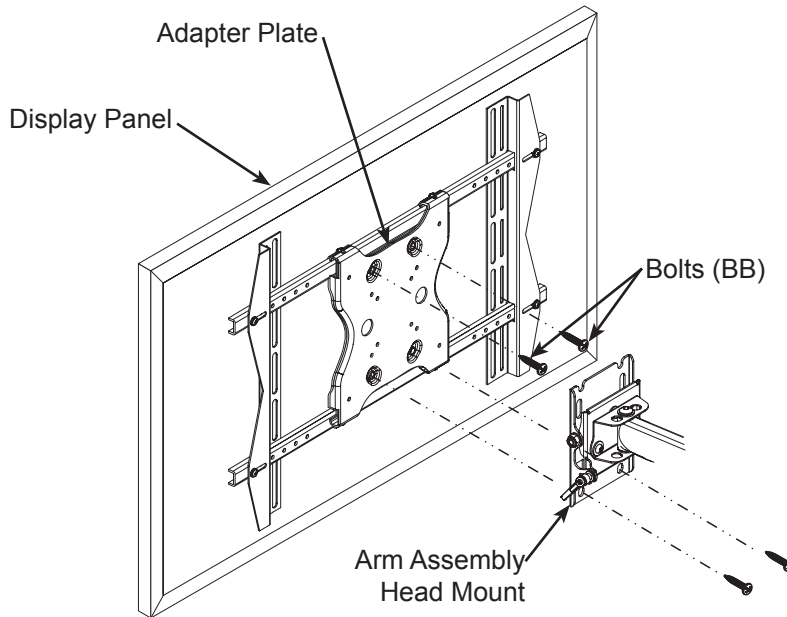

Figure 4

Cable Cover Attachment

1. Route the electrical and data cables along the Arm Assembly and secure in place using the provided Cable Covers (Figure 5).

NOTE: Ensure enough slack is provided to allow for vertical and horizontal move before attaching the Cable Covers.

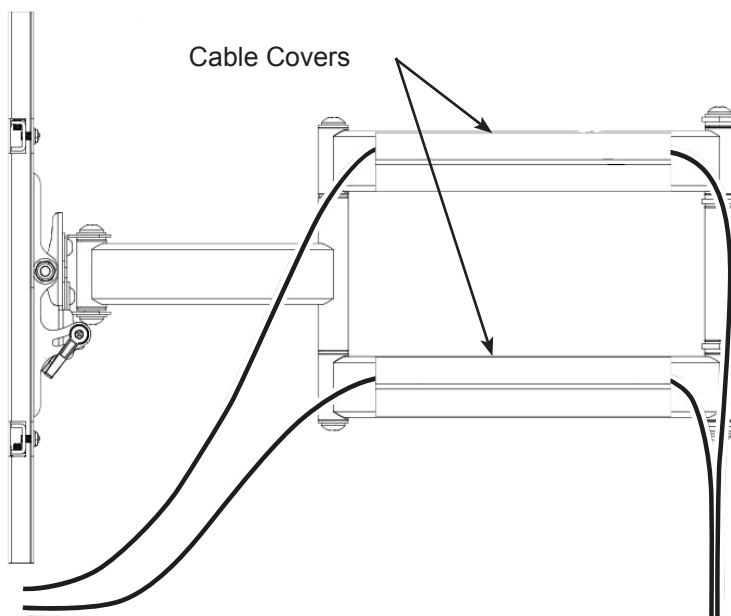

Figure 5

ADJUSTMENTS

Tilt Adjustment

1. Loosen Tilt Levers on each side of mount head (only enough to allow controlled adjustment) (Figure 6).
2. Adjust tilt.
3. Tighten locking Tilt Levers.

NOTE: Once the tilt levers are locked, the position of the levers can be adjusted without loosening or tightening the unit by pulling the levers outward and then repositioning them to a vertical, less obtrusive position.

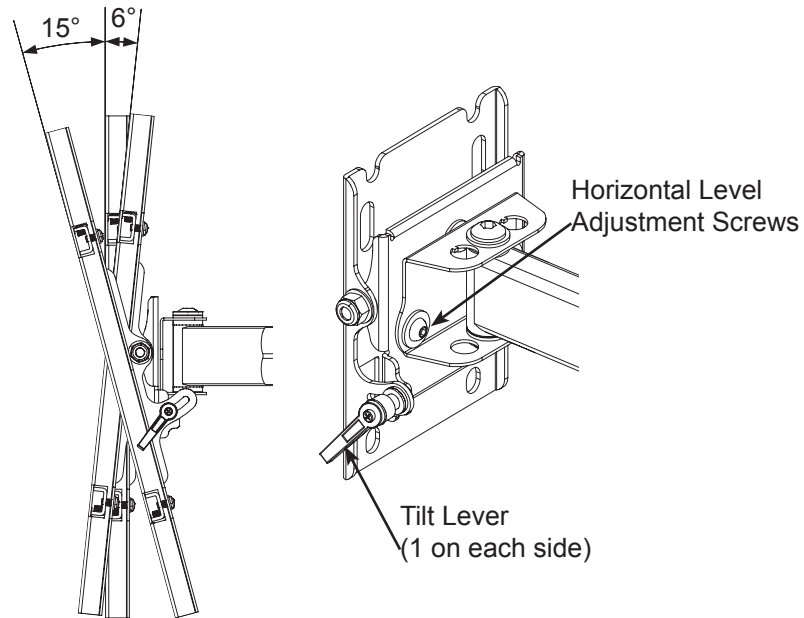

Figure 6

Horizontal Adjustment

1. To adjust the horizontal angle of the display, first slightly loosen the top two screws on back side of the Arm Assembly Head Mount using Allen Key. Then firmly hold opposite corners of the display and gently turn it into the desired position. When level, re-tighten screws to lock in position (Figure 6 and Figure 7).

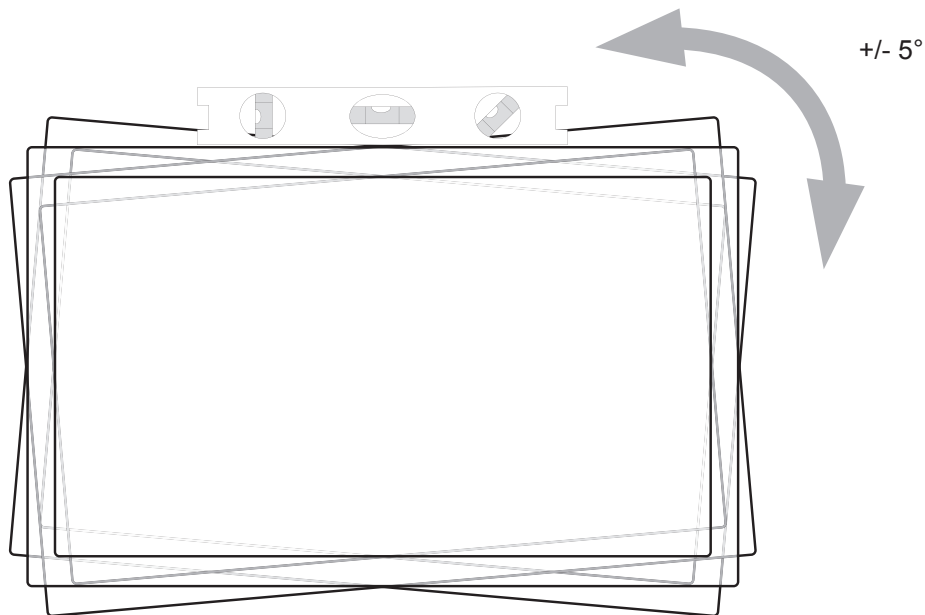

Figure 7

CONTACTING TECHNICAL SUPPORT

Phone: (866) 838-5052

Email: techsupport@snapav.com

LIFETIME LIMITED WARRANTY



Strong™ Mounts have a Lifetime Limited Warranty. This warranty includes parts and labor repairs on all components found to be defective in material or workmanship under normal conditions of use. This warranty shall not apply to products which have been abused, modified or disassembled. Products to be repaired under this warranty must be returned to Snap AV or a designated service center with prior notification and an assigned return authorization (RA) number.



150120_2300
© 2015 STRONG