

A3 DRG. No.

PROPRIETARY INFORMATION
This document contains proprietary information which is forwarded to you in confidence for a specific purpose. It shall not be reproduced nor transferred to other documents nor disclosed to others, nor used for manufacturing or any other purpose without the prior written permission of Digital Projection Ltd. It shall be returned immediately upon request.

DRAWN BS 308
3rd Angle Projection

Distribution Code

Last Change
DATE OF ISSUE -16-7-21

ITEM	DESCRIPTION	REFER TO	No Off	REMARKS
3				
2				
1				
	MATERIAL	FINISH		
A				
PRE REVS	CODE			

TOLERANCES UNLESS OTHERWISE STATED

METRIC: 1.000 = ±0.01
1.00 = ±0.1
1.0 = ±0.2
1 = ±0.4

IMPERIAL: Fractional ±1/64"
Decimal ± 0.005"

ANGLES ± 0° 30'

CAD GENERATED DRAWING. DO NOT MAKE MANUAL CHANGES

UNLESS OTHERWISE STATED
REMOVE ALL BURRS & SHARP EDGES. DO NOT SCALE DRAWING
THE SURFACE TEXTURE ROUGHNESS NUMBER OF MACHINED SURFACES SHOULD BE EQUAL TO OR LESS THAN 0.8um (N6 CLA32)

DIMENSIONS IN MILLIMETRES

REV.	A
NOTE	
DRAWN	jcharnley
APP.DO.	
DATE	01-03-21

FIRST USED ON

ORIGINAL SCALE **1:7**

DRAWN **jcharnley**

APP.ENG.

DATE **06-12-19**

DIGITAL PROJECTION MIDDLETON M24 1XX

SEE ABOVE

COMPONENT OR DRG.No.
SEE ABOVE

A3:SHEET **1 OF 2**

1 2 3 4 5 6 7

IF IN DOUBT, ASK.

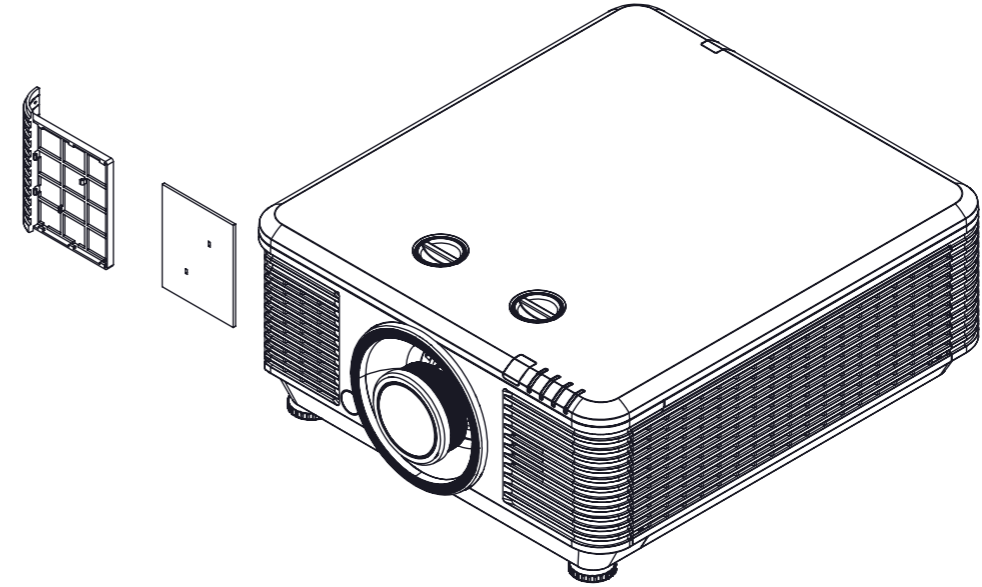
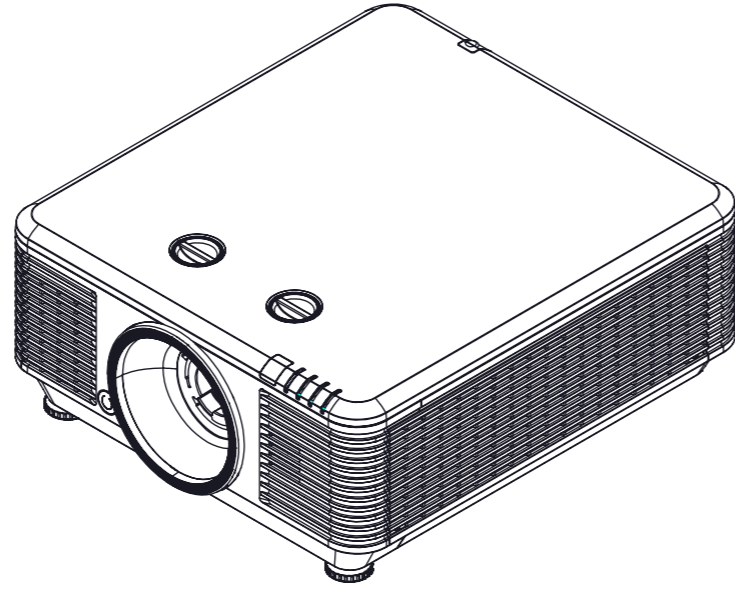
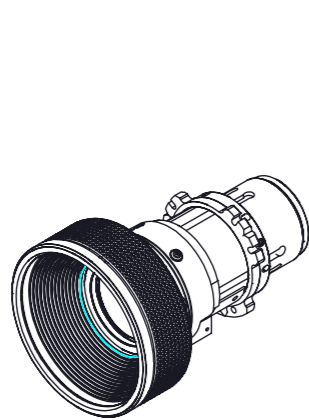
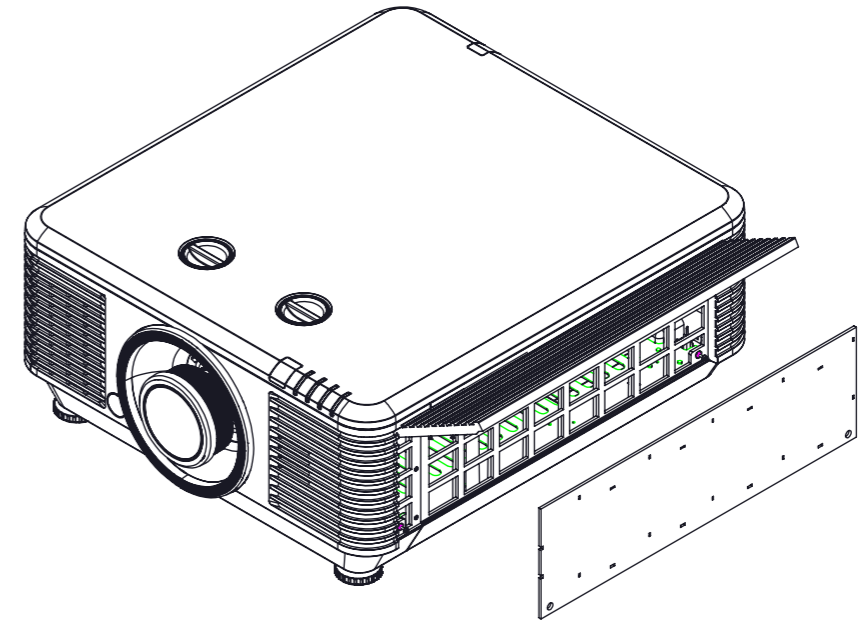
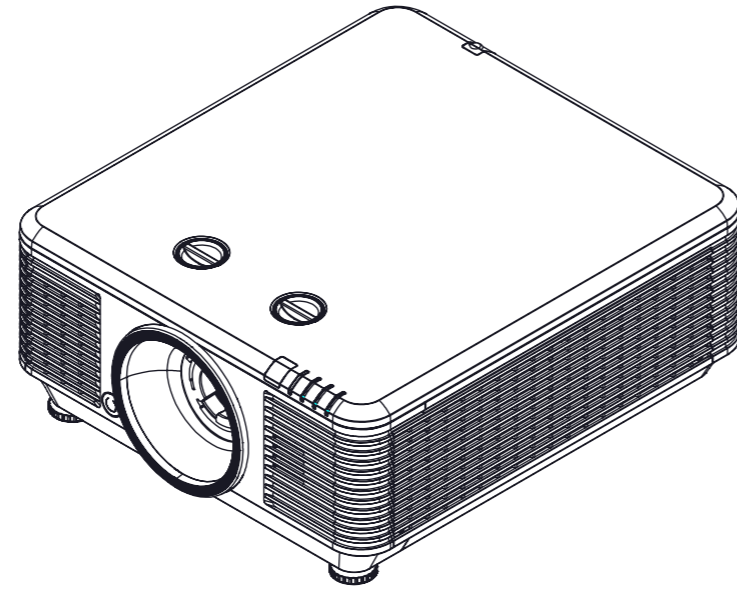

A3 DRG. No.

PROPRIETARY INFORMATION
This document contains proprietary information which is forwarded to you in confidence for a specific purpose. It shall not be reproduced nor transferred to other documents nor disclosed to others, nor used for manufacturing or any other purpose without the prior written permission of Digital Projection Ltd. It shall be returned immediately upon request.

DRAWN BS 308
3rd Angle Projection

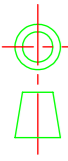

Distribution Code

Last Change

DATE OF ISSUE -16-7-21

A

B

C

D

E

3					
2					
1					
ITEM	DESCRIPTION	REFER TO	No Off	REMARKS	
	MATERIAL	FINISH			
A					
PRE REVS	CODE				

TOLERANCES UNLESS OTHERWISE STATED		CAD GENERATED DRAWING. DO NOT MAKE MANUAL CHANGES			
METRIC: 1.000 = ±0.01 1.00 = ±0.1 1.0 = ±0.2 1 = ±0.4		DIMENSIONS IN MILLIMETRES			
IMPERIAL: Fractional ±1/64" Decimal ± 0.005"		REV.	A		
ANGLES ± 0° 30'		NOTE			
		DRAWN	jcharnley		
		APP.DO.			
		DATE	01-03-21		

FIRST USED ON	
ORIGINAL SCALE	1:7
DRAWN	jcharnley
APP.ENG.	
DATE	06-12-19

DIGITAL PROJECTION MIDDLETON M24 1XX

TITLE

COMPONENT OR DRG.No.

A3:SHEET 2 OF 2