

# Freya



## User guide

## **Product revision**

Software Revision: : 1.5.0

### **Barco NV**

Beneluxpark 21, 8500 Kortrijk, Belgium  
[www.barco.com/en/support](http://www.barco.com/en/support)  
[www.barco.com](http://www.barco.com)

### **Registered office: Barco NV**

President Kennedypark 35, 8500 Kortrijk, Belgium  
[www.barco.com/en/support](http://www.barco.com/en/support)  
[www.barco.com](http://www.barco.com)

## Changes

Barco provides this manual 'as is' without warranty of any kind, either expressed or implied, including but not limited to the implied warranties or merchantability and fitness for a particular purpose. Barco may make improvements and/or changes to the product(s) and/or the program(s) described in this publication at any time without notice.

This publication could contain technical inaccuracies or typographical errors. Changes are periodically made to the information in this publication; these changes are incorporated in new editions of this publication.

The latest edition of Barco manuals can be downloaded from the Barco web site [www.barco.com](http://www.barco.com) or from the secured Barco web site <https://www.barco.com/en/signin>.

## Copyright ©

All rights reserved. No part of this document may be copied, reproduced or translated. It shall not otherwise be recorded, transmitted or stored in a retrieval system without the prior written consent of Barco.

## Trademarks

Brand and product names mentioned in this manual may be trademarks, registered trademarks or copyrights of their respective holders. All brand and product names mentioned in this manual serve as comments or examples and are not to be understood as advertising for the products or their manufacturers.

## Product Security Incident Response

As a global technology leader, Barco is committed to deliver secure solutions and services to our customers, while protecting Barco's intellectual property. When product security concerns are received, the product security incident response process will be triggered immediately. To address specific security concerns or to report security issues with Barco products, please inform us via contact details mentioned on <https://www.barco.com/psirt>. To protect our customers, Barco does not publically disclose or confirm security vulnerabilities until Barco has conducted an analysis of the product and issued fixes and/or mitigations.

## Patent protection

Please refer to [www.barco.com/about-barco/legal/patents](http://www.barco.com/about-barco/legal/patents).

## Guarantee and Compensation

Barco provides a guarantee relating to perfect manufacturing as part of the legally stipulated terms of guarantee. On receipt, the purchaser must immediately inspect all delivered goods for damage incurred during transport, as well as for material and manufacturing faults Barco must be informed immediately in writing of any complaints.

The period of guarantee begins on the date of transfer of risks, in the case of special systems and software on the date of commissioning, at latest 30 days after the transfer of risks. In the event of justified notice of complaint, Barco can repair the fault or provide a replacement at its own discretion within an appropriate period. If this measure proves to be impossible or unsuccessful, the purchaser can demand a reduction in the purchase price or cancellation of the contract. All other claims, in particular those relating to compensation for direct or indirect damage, and also damage attributed to the operation of software as well as to other services provided by Barco, being a component of the system or independent service, will be deemed invalid provided the damage is not proven to be attributed to the absence of properties guaranteed in writing or due to the intent or gross negligence or part of Barco.

If the purchaser or a third party carries out modifications or repairs on goods delivered by Barco, or if the goods are handled incorrectly, in particular if the systems are operated incorrectly or if, after the transfer of risks, the goods are subject to influences not agreed upon in the contract, all guarantee claims of the purchaser will be rendered invalid. Not included in the guarantee coverage are system failures which are attributed to programs or special electronic circuitry provided by the purchaser, e.g. interfaces. Normal wear as well as normal maintenance are not subject to the guarantee provided by Barco either.

The environmental conditions as well as the servicing and maintenance regulations specified in this manual must be complied with by the customer.

## **Software License Agreement**

You should carefully read the following terms and conditions before using this software. Your use of this software indicates your acceptance of this license agreement and warranty.

### **Terms and Conditions:**

1. No redistribution of the software is allowed.
2. Reverse-Engineering. You may not reverse engineer, decompile, disassemble or alter this software product.

### **Disclaimer of Warranty:**

This software and the accompanying files are sold "as is" and without warranties as to performance or merchantability or any other warranties whether expressed or implied. In no event shall Barco be liable for damage of any kind, loss of data, loss of profits, business interruption or other pecuniary loss arising directly or indirectly. Any liability of the seller will be exclusively limited to replacement of the product or refund of purchase price.

### **GNU-GPL code**

If you would like a copy of the GPL source code contained in this product shipped to you on CD, please contact Barco. The cost of preparing and mailing a CD will be charged.

# Table of contents

<b>1</b>	<b>Safety</b>	<b>13</b>
1.1	General considerations	14
1.2	Safety training to be provided by the installer	15
1.3	Important safety instructions	16
1.4	Product safety labels	20
1.5	High Brightness precautions: Hazard Distance	22
1.6	HD for fully enclosed projection systems	24
1.7	HD in function of modifying optics	26
<b>2</b>	<b>Getting started</b>	<b>27</b>
2.1	Explaining the power states	28
2.2	Switching the projector ON	30
2.3	Connecting to the projector for the first time	31
2.4	Switching the projector OFF	32
2.5	Operation in 24/7 Mode	33
2.6	Web Communicator	34
2.7	Web Commander	34
<b>3</b>	<b>ICMP-X</b>	<b>37</b>
3.1	ICMP-X configuration via Web Communicator	38
3.2	ICMP-X status LEDs	38
3.3	HDD status LEDs	39
3.4	Removing a HDD from the ICMP-X	41
3.5	Installing a HDD into the ICMP	42
3.6	ICMP-X reset	44
<b>4</b>	<b>Web Communicator – Graphical User Interface (GUI)</b>	<b>45</b>
4.1	Graphical User Interface	46
4.2	Starting up	49
4.3	Installing SSL certificate to enable HTTPS protocol	50
4.4	Reset administrator password	54
4.5	Signing out from application	55
4.6	Modifying account settings (password)	56
4.7	Modifying preferences (language, theme, time format)	57
4.8	Search	58
4.9	Dashboard	59

4.10	User rights.....	60
4.11	Displaying open source license list.....	61
4.12	Application Menu tree.....	62
<b>5</b>	<b>Projector configuration process overview.....</b>	<b>65</b>
5.1	Prerequisites.....	66
5.2	Process overview.....	66
<b>6</b>	<b>Control - Projector.....</b>	<b>69</b>
6.1	Macros control.....	70
6.1.1	About macro control.....	70
6.1.2	Activating a macro using the control menu.....	70
6.2	Light, dowser, lens.....	71
6.2.1	About Light, dowser, lens menu.....	71
6.2.2	Light Source on-off.....	72
6.2.3	Light Source power increase-decrease.....	72
6.2.4	Dowser open-close.....	73
6.2.5	Test pattern on-off.....	73
6.2.6	Lens zoom.....	74
6.2.7	Lens focus.....	74
6.2.8	Lens shift.....	74
6.2.9	Control key shortcut.....	75
6.3	Test patterns control.....	76
6.3.1	About test patterns control.....	76
6.3.2	Activating a test pattern using the control menu.....	77
6.3.3	Deactivating a test pattern using the control menu.....	78
6.4	Power.....	80
6.4.1	About Power menu.....	80
6.4.2	Switching to ECO mode.....	81
6.4.3	Rebooting the media server.....	82
6.4.4	Full system reboot.....	82
6.5	Scheduler.....	83
6.5.1	About Scheduler.....	83
6.5.2	Scheduling of automatic switches on or shutdowns of the projector.....	84
<b>7</b>	<b>Configuration - Projector.....</b>	<b>87</b>
7.1	Macros configuration.....	88
7.1.1	About macro configuration.....	88
7.1.2	Creating a new macro.....	89
7.1.3	Creating a new macro from active state.....	90
7.1.4	Macro editor.....	90
7.1.4.1	General.....	90
7.1.4.2	Adding a command to a macro.....	91
7.1.4.3	Deleting a command from a macro file.....	93
7.1.4.4	Editing values of macro commands.....	93
7.1.4.5	Changing the order of Macro commands.....	94
7.1.5	Editing a macro.....	95
7.1.6	Renaming a macro.....	96
7.1.7	Activating a macro using the configuration menu.....	97
7.1.8	Saving a macro as cue on media server.....	99
7.1.9	Linking a macro to preset button.....	99
7.1.10	Removing a macro from preset buttons.....	100
7.1.11	Importing a macro.....	101
7.1.12	Exporting a macro.....	102

7.1.13	Exporting several macro files in a backup package .....	103
7.1.14	Deleting a macro .....	104
7.1.15	Deleting several macro files .....	105
7.2	PCF .....	105
7.2.1	About PCF .....	105
7.2.2	Creating a PCF with active configuration .....	106
7.2.3	Activating a PCF .....	107
7.2.4	Renaming a PCF .....	108
7.2.5	Importing a PCF .....	109
7.2.6	Exporting a PCF .....	110
7.2.7	Exporting several PCF in a backup package .....	111
7.2.8	Deleting a PCF .....	113
7.2.9	Deleting several PCF .....	113
7.3	Lens selection .....	114
7.3.1	About Lens selection .....	114
7.3.2	Activating a lens .....	115
7.3.3	Calibrating a lens .....	116
7.4	Lens position .....	118
7.4.1	About Lens position .....	118
7.4.2	Creating a lens position file .....	119
7.4.3	Editing a Lens position file .....	121
7.4.4	Activating a lens position file .....	122
7.4.5	Renaming a lens position file .....	122
7.4.6	Importing a Lens position file .....	123
7.4.7	Exporting a Lens position file .....	124
7.4.8	Exporting several lens position files in a backup package .....	125
7.4.9	Deleting a Lens position file .....	126
7.4.10	Deleting several Lens position file .....	127
7.5	3D .....	127
7.5.1	About 3D file .....	127
7.5.2	Creating a 3D file .....	129
7.5.3	3D file editor .....	131
7.5.3.1	3D Test pattern .....	131
7.5.3.2	3D control .....	132
7.5.3.3	Dark time adjustment .....	133
7.5.3.4	Output Reference Delay .....	134
7.5.3.5	Auto switch delay time adjustment .....	136
7.5.4	Editing a 3D file .....	137
7.5.5	Activating a 3D file .....	138
7.5.6	Renaming a 3D file .....	139
7.5.7	Importing a 3D file .....	140
7.5.8	Exporting a 3D file .....	141
7.5.9	Exporting several 3D files in a backup package .....	142
7.5.10	Delete a 3D file .....	143
7.5.11	Deleting several 3D files .....	144
7.6	Input .....	145
7.6.1	About Input file .....	145
7.6.2	Creating an input file .....	146
7.6.3	Input file editor .....	147
7.6.3.1	HDSDI (3G-SDI) for ICMP .....	147
7.6.3.2	HDMI .....	149
7.6.3.3	Media player .....	150
7.6.4	Editing an input file .....	151
7.6.5	Activating an input file .....	152

7.6.6	Renaming input file .....	153
7.6.7	Importing an input file .....	154
7.6.8	Exporting an input file .....	155
7.6.9	Exporting several input files in a backup package .....	156
7.6.10	Delete an input file .....	158
7.6.11	Deleting several input files .....	158
7.7	Picture .....	159
7.7.1	About screen file .....	159
7.7.2	Creating a screen file .....	160
7.7.3	Screen file editor .....	161
7.7.3.1	Cropping (active area) .....	162
7.7.3.2	Scaling .....	163
7.7.3.3	Masking .....	167
7.7.4	Editing a Screen file .....	168
7.7.5	Activating a screen file .....	169
7.7.6	Renaming a screen file .....	171
7.7.7	Importing a screen file .....	172
7.7.8	Exporting a screen file .....	172
7.7.9	Exporting several screen files in a backup package .....	173
7.7.10	Delete a screen file .....	174
7.7.11	Deleting several screen files .....	175
7.8	Test patterns .....	176
7.8.1	About test patterns .....	176
7.8.2	Activating a test pattern using configuration menu .....	177
7.8.3	Deactivating a test pattern using configuration menu .....	177
7.8.4	Assign a test pattern to a shortcut .....	178
7.8.5	Removing a test pattern from a shortcut .....	179
7.8.6	Importing a test pattern .....	180
7.8.7	Exporting a test pattern .....	181
7.8.8	Exporting several test patterns in a backup package .....	182
7.8.9	Delete a test pattern .....	184
7.8.10	Deleting several test pattern files .....	184
7.9	Internal clock settings .....	185
7.9.1	About Internal clock settings .....	185
7.9.2	Setting the internal clock of the projector .....	186
7.10	Image Orientation .....	188
7.10.1	Changing image orientation .....	188

## 8 Configuration - Light output ..... 191

8.1	Light sensor calibration (LSC) .....	192
8.1.1	About light sensor calibration .....	192
8.1.2	Creating a new light sensor calibration file .....	193
8.1.3	Activating a light sensor calibration file .....	194
8.1.4	Deleting a light sensor calibration file .....	195
8.1.5	Editing a light sensor calibration file .....	195
8.1.6	Renaming a light sensor calibration file .....	196
8.2	Light output mode .....	197

## 9 Configuration - Color calibration ..... 201

9.1	Calibration process overview .....	202
9.2	Light source – White Point calibration .....	202
9.2.1	About the light source white point calibration menu .....	202
9.2.2	White point calibration .....	204
9.3	Projector color .....	207



9.3.1	About Color calibration .....	207
9.3.2	Creating a new MCGD file .....	208
9.3.3	Editing an active MCGD file .....	208
9.3.4	Exporting and importing MCGD files .....	209
9.3.5	Deleting several MCGD files .....	210
9.4	Verifying the colors after correction .....	211
9.5	Spatial color calibration .....	214
9.5.1	About spatial color calibration .....	214
9.5.2	Activating a SCC file .....	215
9.5.3	Renaming a SCC file .....	215
9.5.4	Deleting a SCC file .....	216
9.5.5	Creating a new SCC file .....	217
9.5.6	Exporting and importing SCC files .....	219
9.5.7	Deleting several SCC files .....	220
<b>10</b>	<b>Configuration - Projector automation .....</b>	<b>221</b>
10.1	Allocating a macro to a general purpose input (GPI) .....	222
10.2	Associating a general purpose output to a system event .....	224
10.3	Changing GPO status manually .....	226
<b>11</b>	<b>Configuration - Media server automation .....</b>	<b>229</b>
11.1	Devices .....	230
11.1.1	About devices .....	230
11.1.2	Add a new device .....	230
11.1.3	Update an existing device .....	231
11.1.4	Delete an existing device .....	232
11.1.5	Import and export devices .....	233
11.2	Groups .....	233
11.2.1	Creating a new automation group .....	233
11.2.2	Edit an existing group .....	235
11.2.3	Rename a group .....	235
11.2.4	Delete a group .....	236
11.2.5	Import and export groups .....	236
11.3	User cues .....	237
11.3.1	About automation cues .....	237
11.3.2	Create a new User Cue .....	239
11.3.3	Devices and commands .....	242
11.3.4	Edit a user cue .....	243
11.3.5	Rename a user cue .....	243
11.3.6	Delete a user cue .....	244
11.3.7	Editing a System Cue .....	245
11.3.8	Adding an Input Cue to an event .....	247
11.3.9	Edit an action in an Input Cue .....	250
11.3.10	Export automation settings .....	250
11.3.11	Import automation settings .....	251
<b>12</b>	<b>Configuration - License and certificates .....</b>	<b>255</b>
12.1	Managing licenses .....	256
12.2	Managing certificates .....	258
12.3	Projector registration .....	260
<b>13</b>	<b>Configuration - Media server .....</b>	<b>263</b>
13.1	Content .....	264
13.1.1	About Content settings .....	264

13.1.2	Create a new content device .....	264
13.1.3	Modify a content device .....	267
13.1.4	Delete a content device .....	269
13.2	Player .....	270
13.2.1	About Player settings .....	270
13.2.2	Modifying the player settings .....	270
13.3	Scheduler .....	271
13.3.1	About scheduler settings .....	271
13.3.2	Modify the scheduler settings .....	272
13.4	Immersive sound .....	273
13.5	Audio channel .....	274
13.5.1	About audio channel configuration .....	274
13.5.2	Modify the audio channels .....	275
<b>14</b>	<b>Configuration - System access .....</b>	<b>277</b>
14.1	Network configuration .....	278
14.1.1	About network configuration .....	278
14.1.2	Assigning an auditorium name to the projector .....	280
14.1.3	Assigning a host name and a domain to the projector .....	281
14.1.4	Assigning a network address .....	282
14.2	User management .....	285
14.2.1	About the user management menu .....	285
14.2.2	Menu access control editor .....	285
14.2.3	Creating a user .....	287
14.2.4	Modifying settings of a user .....	288
14.2.5	Deleting a user .....	290
14.3	Marriage pin code .....	290
14.3.1	About marriage PIN code .....	290
14.3.2	Creating a new marriage PIN code .....	291
14.3.3	Deleting a marriage PIN code .....	292
14.3.4	Modifying a marriage PIN code .....	293
14.4	SNMP .....	294
14.4.1	About SNMP configuration .....	294
14.4.2	Modifying the trap resend interval .....	295
14.4.3	Adding a new SNMP receiver .....	296
14.4.4	Deleting a SNMP receiver .....	296
14.4.5	Modifying the IP of a SNMP receiver .....	297
14.5	Multi projectors .....	298
14.5.1	About Multi projectors .....	298
14.5.2	Linked ICMP (Adding, modifying and deleting a slave projector) .....	300
14.5.3	Linked CLO (Adding, modifying, verifying and deleting a slave projector) .....	302
<b>15</b>	<b>Diagnostics - Monitoring .....</b>	<b>307</b>
15.1	System information .....	308
15.2	RAID information .....	309
15.3	Notifications .....	309
15.4	Metrics .....	312
<b>16</b>	<b>Diagnostics - Analysis .....</b>	<b>315</b>
16.1	Self test .....	316
16.2	Diagnostic package .....	317
16.3	Reading a diagnostic package .....	318
<b>17</b>	<b>Maintenance .....</b>	<b>321</b>

17.1	Software update.....	322
17.2	Service mode .....	325
17.3	Backup and restore.....	325
17.3.1	Download and restore full system backup .....	325
17.3.2	Download and restore ICMP settings .....	328
17.3.3	Factory restore .....	330
17.4	Raid Storage.....	332
17.4.1	Raid status .....	332
17.4.2	Initialize RAID storage.....	333
17.4.3	File system check .....	334
17.5	Laser management.....	335
17.5.1	Laser Bank status .....	335
<b>18</b>	<b>Preventive maintenance actions .....</b>	<b>337</b>
18.1	1 month maintenance actions .....	338
18.2	3 month maintenance actions .....	338
<b>19</b>	<b>Maintenance procedures .....</b>	<b>339</b>
19.1	Checking the front filters .....	340
19.2	Checking the rear dust filters.....	341
19.3	Checking the LDM dust filter.....	342
19.4	Vacuum cleaning of the dust filters .....	342
19.5	Washing and drying the dust filters .....	343
19.6	Cleaning the lens .....	344
19.7	Cleaning the exterior of the projector.....	345
19.8	Authorization to clear a security warning on the projector .....	345
<b>20</b>	<b>Removal and installation of projector covers without frame .....</b>	<b>347</b>
20.1	Removal of the front cover .....	348
20.2	Removal of the rear cover .....	348
20.3	Mounting the rear cover .....	349
20.4	Mounting the front cover .....	350
<b>21</b>	<b>Removal and installation of projector covers with reinforcement frame .....</b>	<b>351</b>
21.1	Removal of the front cover .....	352
21.2	Removal of the rear cover.....	352
21.3	Mounting the rear cover .....	353
21.4	Mounting the front cover .....	355
<b>A</b>	<b>Specifications .....</b>	<b>357</b>
A.1	Specifications Freya .....	358
A.2	Specification Freya MKII .....	360
A.3	Specification Freya+ .....	362
A.4	Specifications of the ICMP-X.....	364
A.5	ICMP-X SDI specifications .....	365
A.6	ICMP-X HDMI 2.0 specifications.....	368
<b>B</b>	<b>Pin configurations.....</b>	<b>373</b>
B.1	About General Purpose Inputs & Outputs (GPIO).....	374
B.2	Pin configurations of the communication ports .....	375
B.3	Pin configurations of the ICMP-X communication ports.....	378
B.4	Pin configurations of the inputs.....	380
<b>C</b>	<b>Regulatory information .....</b>	<b>383</b>
C.1	Product compliance .....	384

C.2	Taiwan RoHS compliance .....	385
C.3	China RoHS compliance.....	386
C.4	Turkey RoHS compliance.....	387
C.5	Disposal information.....	387
C.6	Hazards .....	387
C.7	Production address .....	388
C.8	Contact information.....	388
C.9	Download Product Manual .....	388
	<b>Glossary .....</b>	<b>389</b>
	<b>List of tools .....</b>	<b>391</b>
	<b>Index .....</b>	<b>393</b>

# Safety

# 1

1.1	General considerations .....	14
1.2	Safety training to be provided by the installer .....	15
1.3	Important safety instructions .....	16
1.4	Product safety labels.....	20
1.5	High Brightness precautions: Hazard Distance.....	22
1.6	HD for fully enclosed projection systems.....	24
1.7	HD in function of modifying optics .....	26

## About this chapter

Read this chapter attentively. It contains important information to prevent personal injury while installing and using your Freya projector. Furthermore, it includes several cautions to prevent damage to your Freya projector. Ensure that you understand and follow all safety guidelines, safety instructions and warnings mentioned in this chapter before installing and using the Freya projector. After this chapter, additional “warnings” and “cautions” are given depending on the procedure. Read and follow these “warnings” and “cautions” as well.

## Clarification of the term “Freya” used in this document

When referring in this document to the term “Freya” means that the content is applicable for following Barco products:

- Freya, Freya MKII, Freya+



The Freya MKII is the successor of the Freya. Freya MKII has adaptations to the internal lightpath to achieve higher contrast. It is not possible to rebuild a Freya to a Freya MKII.

## Model certification name

- Freya: SP4K-12C
- Freya MKII: SP4K-7CHC
- Freya+: SP4K-12CHC



Barco provides a guarantee relating to perfect manufacturing as part of the legally stipulated terms of guarantee. Observing the specification mentioned in this chapter is critical for projector performance. Neglecting this can result in loss of warranty.

## 1.1 General considerations

### General safety instructions

- Before operating this equipment please read this manual thoroughly and retain it for future reference.
- Installation and preliminary adjustments should be performed by qualified Barco personnel or by authorized Barco service dealers.
- All warnings on the projector and in the documentation manuals should be adhered to.
- All instructions for operating and use of this equipment must be followed precisely.
- All local installation codes should be adhered to.

### Notice on safety

This equipment is built in accordance with the requirements of the applicable international safety standards. These safety standards impose important requirements on the use of safety critical components, materials and insulation, in order to protect the user or operator against risk of electric shock and energy hazard and having access to live parts. Safety standards also impose limits to the internal and external temperature rises, radiation levels, mechanical stability and strength, enclosure construction and protection against the risk of fire. Simulated single fault condition testing ensures the safety of the equipment to the user even when the equipment's normal operation fails.

### Notice on optical radiation

This projector embeds extremely high brightness (radiance) lasers; this laser light is processed through the projector's optical path. Native laser light is not accessible by the end user in any use case. The light exiting the projection lens has been diffused within the optical path, representing a larger source and lower radiance value than native laser light. Nevertheless the projected light represents a significant risk for the human eye and skin when exposed directly within the beam. This risk is not specifically related to the characteristics of laser light but solely to the high thermal induced energy of the light source; which is equivalent with lamp based systems.

Thermal retinal eye injury is possible when exposed within the Hazard Distance (HD). The HD is defined from the projection lens surface towards the position of the projected beam where the irradiance equals the maximum permissible exposure as described in the chapter "Hazard Distance".



**WARNING:** No direct exposure to the beam within the hazard distance shall be permitted, RG3 (Risk Group 3) IEC EN 62471-5:2015



**CAUTION:** Use of controls or adjustments or performance of procedures other than those specified herein may result in hazardous radiation exposure.

### Restricted access location

This product may only be installed in a restricted access location. The definition of a "restricted access location" is a location for equipment where both of following applies:

- Access can only be gained by SERVICE PERSONNEL or by OPERATORS who have been instructed about the reasons for the restriction applied to the location and about the precautions that shall be taken.
- Access is through the use of the tool or lock and key, or other means of security, and is controlled by the authority responsible for the location.

Why a restricted access location: This is a RG3 product. Based on international requirements, no person is allowed to enter the projected beam within the zone between the projection lens and the related Hazard Distance (HD). This shall be physically impossible by creating sufficient separation height or by placing optional barriers. Within the restricted area operator training is considered sufficient. The applicable separation heights are discussed in "[High Brightness precautions: Hazard Distance](#)", page 22.

### Users definition

Throughout this manual, the terms SERVICE PERSONNEL and TRAINED PROJECTIONIST refers to persons having appropriate technical training and experience necessary to be knowledgeable of potential hazards to which they are exposed (including, but not limited to HIGH VOLTAGE ELECTRIC and ELECTRONIC CIRCUITRY and HIGH BRIGHTNESS PROJECTORS) in performing a task, and of measures

to minimize the potential risk to themselves or other persons. The term USER and OPERATOR refers to any person other than SERVICE PERSONNEL or TRAINED PROJECTIONISTS, AUTHORIZED to operate professional projection systems.

The TRAINED PROJECTIONISTS may only perform the maintenance task described in the User & Installation manual. All other maintenance tasks and service tasks must be performed by qualified SERVICE PERSONNEL.

The DLP Cinema Systems are intended "FOR PROFESSIONAL USE ONLY" by AUTHORIZED PERSONNEL familiar with potential hazards associated with high voltage, high intensity light beams generated by lasers. Only qualified SERVICE PERSONNEL and TRAINED PROJECTIONISTS, knowledgeable of such risks, are allowed to perform service functions inside the product enclosure.

## 1.2 Safety training to be provided by the installer



**WARNING:** The installer is responsible that the user is instructed. The user will sign a document to confirm that the instructions have been received and understood.



Refer to document "Declaration of user safety training" (Document number 601-0462) for training tick off and signing. Document can be found on the Barco website if not included in the box.

### Usage

The Freya is intended for persons who have been instructed and trained by a skilled person (installer or service personnel) to identify energy sources that may cause injury and to take precautions to avoid unintentional contact with or exposure to those energy sources.

The skilled person must instruct the user about:

- High intensity light beam. The user must respect the exclusion zone, based on the light beam Hazard Distance (HD).
- Dangerous energy sources inside the projector. The user is not allowed to remove any cover from the projector.
- The installation, maintenance or service is for skilled persons only.
- The requirements for a **restricted access location** and a **restriction zone**.

### Restricted access location

To protect untrained persons and children, the projector must be installed in a **restricted access location**. The definition of a **restricted access location** is a location for equipment where both of the following paragraphs apply:

- Access can only be gained by skilled persons (installer or service personnel) or persons who have been instructed and trained by a skilled person. The persons must have been instructed about the reasons for the restriction applied to the location and about the precautions that shall be taken.
- Access is only possible through the use of the tool or lock and key, or other means of security, and is controlled by the authority responsible for the location.

Why a restricted access location: this is an RG3 product. Based on international requirements, no person is allowed to enter the projected beam within the zone between the projection lens and the related Hazard Distance (HD). This shall be physically impossible by creating sufficient separation height and width or by placing optional barriers. Within the restricted area operator training is considered sufficient. The applicable separation heights and widths are discussed in "[High Brightness precautions: Hazard Distance](#)", page 22.

### Exclusion zone

The projector radiates heat on its external surfaces and from ventilation ducts during normal operation. Exposing flammable or combustible materials into close proximity of this projector could result in the spontaneous ignition of that material, resulting in a fire. For this reason, it is absolutely necessary to leave an exclusion zone around all external surfaces of the projector whereby no flammable or combustible materials are present:

- The exclusion zone must not be less than 40 cm (16 in).

## 1.3 Important safety instructions

### To prevent the risk of electrical shock

- This projector should be operated from an AC power source. Ensure that the mains voltage and capacity matches the projector electrical ratings. If you are unable to install the AC power requirements, contact your electrician. Do not defeat the purpose of the grounding.
- Installation should be done according to the local electrical code and regulations by qualified technical personnel only.
- This product is equipped with a 5-terminal barrier strip for the connection of a power line. The projector can run on one of the following configurations, depending on what power system is available:
  - A 3W+N+PE power system (Y configuration).
  - A 3W+PE power system ( $\Delta$  configuration).
  - A mono phase system with power line with a separate earth ground PE.
 If you are unable to install the AC power requirements, contact your electrician. Do not defeat the purpose of the grounding.
- This product is equipped with a 3-terminal barrier strip for the connection of a UPS power cord (2-pole, 3-wire grounding).
- The electronics of the projector (UPS INLET) must be powered from a suitable UPS unit. The building has to be provided with a circuit breaker of max 16A to protect the UPS.
- The building installation has to be provided with a circuit breaker of max 40A to protect the complete unit.
- The circuit breakers are considered as readily accessible disconnect devices that must be incorporated externally to the equipment for removal of the power to the projector mains terminals and UPS inlet terminals.
- The cross-sectional area of the conductors in the power supply cord should be not less than 4 mm<sup>2</sup> (10 AWG) while using a circuit breaker of 40A max. The power cord should have a rating depending on what power system is available:
  - Y configuration: min 500V.
  - $\Delta$  configuration: min 300V.
  - Mono phase configuration: min 300V.
- The cross-sectional area of the UPS inlet cord shall be not less than 1.5 mm<sup>2</sup> (14 AWG) and has a rating of minimum 300V.
- In case of using a circuit breaker of a current rating less than 40A, the cross-sectional area of the conductors in the power supply cord must comply with the local electrical code regulations where the projector is installed.
- The cable gland of the power supply cord has a clamping range between 11 mm and 21 mm ( cable diameter of the power supply cord must be in this range :11-21 mm)
- Disconnect the power to the projector mains terminals for removal of all power from the projector.
- Do not allow anything to rest on the power cord. Do not locate this projector where persons will walk on the cord.
- Do not operate the projector with a damaged cord or if the projector has been dropped or damaged - until it has been examined and approved for operation by a qualified service technician.
- Position the cord so that it will not be tripped over, pulled, or contact hot surfaces.
- If an extension cord is necessary, a cord with a current rating at least equal to that of the projector should be used. A cord rated for less amperage than the projector may overheat.
- Never push objects of any kind into this projector through cabinet slots as they may touch dangerous voltage points or short circuit parts that could result in a risk of fire or electrical shock.
- Do not expose this projector to rain or moisture.
- Do not immerse or expose this projector in water or other liquids.
- Do not spill liquid of any kind on this projector.
- Should any liquid or solid object fall into the cabinet, unplug the set and have it checked by qualified service personnel before resuming operations.
- Do not disassemble this projector, always take it to an trained service person when service or repair work is required.
- Do not use an accessory attachment which is not recommended by the manufacturer.
- Lightning - For added protection for this video product during a lightning storm, or when it is left unattended and unused for long periods of time, remove all power from the projector. This will prevent damage to the projector due to lightning and AC power-line surges.



## To prevent personal injury

- To prevent injury and physical damage, always read this manual and all labels on the system before powering the projector or adjusting the projector.
- Do not underestimate the weight of the projector. The projector weighs  $\pm 105$  kg (  $\pm 231$  lbs). To prevent personal injury a hoisting tool should be used to lift the projector.
- To prevent injury, ensure that the lens, cooling system and all cover plates are correctly installed. See installation procedures.
- Warning: high intensity light beam. NEVER look into the lens ! High luminance could result in damage to the eye.
- **Warning: extremely high brightness projector:** This projector embeds extremely high brightness (radiance) lasers; this laser light is processed through the projector's optical path. Native laser light is not accessible by the end user in any use case. The light exiting the projection lens has been defused within the optical path, representing a larger source and lower radiance value than native laser light. Nevertheless the projected light represents a significant risk for the human eye when exposed directly within the beam. This risk is not specifically related to the characteristics of laser light but solely to the high thermal induced energy of the light source; which is equivalent to lamp based systems. Thermal retinal eye injury is possible when exposed within the Hazard Distance. The Hazard Distance (HD) is defined from the projection lens surface towards the position of the projected beam where the irradiance equals the maximum permissible exposure as described in the chapter "[High Brightness precautions: Hazard Distance](#)", page 22.
- Based on international requirements, no person is allowed to enter the projected beam within the zone between the projection lens and the related Hazard Distance (HD). This shall be made physically impossible by creating sufficient separation height or by placing optional barriers. Within the restricted area operator training is considered sufficient. The applicable separation heights are discussed in "[High Brightness precautions: Hazard Distance](#)", page 22.
- The projector shall be installed in a restricted access room equipped with a key or security lock preventing untrained persons entering the Risk Group 3 use zone.
- Switch off the projector before attempting to remove any of the projector's covers.
- Do not place this equipment on an unstable cart, stand, or table. The product may fall, causing serious damage to it and possible injury to the user.
- It is hazardous to operate without lens or shield. Always switch the output light off when replacing a lens.
- Lenses, shields or screens shall be changed if they have become visibly damaged to such an extent that their effectiveness is impaired. For example by cracks or deep scratches.
- The associated Safety responsible of the unit must evaluate the setup before the unit may be started.
- Never point or allow light to be directed on people or reflective objects within the HD zone.
- All operators shall have received adequate training and be aware of the potential hazards.
- Strictly minimize the number of people who have access to the unit. The unit may never be operated without permission of the responsible for safety.
- Do not put your hand or any body part in front of the beam.  
Do not clean the port window when the projector is switched on.

## To prevent fire hazard

- Do not place flammable or combustible materials near the projector!
- Barco large screen projection products are designed and manufactured to meet the most stringent safety regulations. This projector radiates heat on its external surfaces and from ventilation ducts during normal operation, which is both normal and safe. Exposing flammable or combustible materials into close proximity of this projector could result in the spontaneous ignition of that material, resulting in a fire. For this reason, it is absolutely necessary to leave an "exclusion zone" around all external surfaces of the projector whereby no flammable or combustible materials are present. The exclusion zone must be not less than 40 cm (16") for this projector.
- Do not place any object in the projection light path at close distance to the projection lens output. The concentrated light at the projection lens output may result in damage, fire or burn injuries.
- Ensure that the projector is solidly mounted so that the projection light path cannot be changed by accident.
- Do not cover the projector or the lens with any material while the projector is in operation. . Mount the projector in a well ventilated area away from sources of ignition and out of direct sun light. Never expose the projector to rain or moisture. In the event of fire, use sand, CO<sub>2</sub> or dry powder fire extinguishers. Never use water on an electrical fire. Always have service performed on this projector by authorized Barco

service personnel. Always insist on genuine Barco replacement parts. Never use non-Barco replacement parts as they may degrade the safety of this projector.

- Slots and openings in this equipment are provided for ventilation. To ensure reliable operation of the projector and to protect it from overheating, these openings must not be blocked or covered. The openings should never be blocked by placing the projector too close to walls, or other similar surface. This projector should never be placed near or over a radiator or heat register. This projector should not be placed in a built-in installation or enclosure unless proper ventilation is provided.
- Projection rooms must be well ventilated or cooled in order to avoid build up of heat. It is necessary to vent hot exhaust air from projector and cooling system to the outside of the building.
- Let the projector cool completely before storing. Remove cord from the projector when storing.

### To prevent battery explosion

- Danger of explosion if battery is incorrectly installed.
- Replace only with the same or equivalent type recommended by the manufacturer.
- For disposal of used batteries, always consult federal, state, local and provincial hazardous waste disposal rules and regulations to ensure proper disposal.

### To prevent projector damage

- The air filters of the projector must be cleaned or replaced on a regular basis. Cleaning the booth area would be monthly-minimum. Neglecting this could result in disrupting the air flow inside the projector, causing overheating. Overheating may lead to the projector shutting down during operation.
- The projector must always be installed in a manner which ensures free flow of air into its air inlets.
- In order to ensure that correct airflow is maintained, and that the projector complies with Electromagnetic Compatibility (EMC) and safety requirements, it should always be operated with all of its covers in place.
- Slots and openings in the cabinet are provided for ventilation. To ensure reliable operation of the product and to protect it from overheating, these openings must not be blocked or covered. The openings should never be blocked by placing the product on a bed, sofa, rug, or other similar surface. This product should never be placed near or over a radiator or heat register. The device should not be placed in a built-in installation or enclosure unless proper ventilation is provided.
- Ensure that nothing can be spilled on, or dropped inside the projector. If this does happen, switch off and remove all power from the projector. Do not operate the projector again until it has been checked by qualified service personnel.
- Do not block the projector cooling fans or free air movement around the projector.
- Proper operation of the projector can only be guaranteed in table mounting (for projector without frame). It is not permitted to use the projector in another position. See installation procedure for correct installation.
- **Special care for Laser Beams:** Special care should be used when DLP projectors are used in the same room as high power laser equipment. Direct or indirect hitting of collimated laser beams on to the lens from outside the projector body can severely damage the Digital Mirror Devices™ in which case there is a loss of warranty.
- Never place the projector in direct sunlight. Sunlight on the lens can severely damage the Digital Mirror Devices™ in which case there is a loss of warranty.
- Save the original shipping carton and packing material. They will come in handy if you ever have to ship your equipment. For maximum protection, repack your set as it was originally packed at the factory.
- Remove all power from the projectors mains terminals before cleaning. Do not use liquid cleaners or aerosol cleaners. Use a damp cloth for cleaning. Never use strong solvents, such as thinner or benzine or abrasive cleaners, since these will damage the cabinet. Persistent stains may be removed with a cloth lightly dampened with mild detergent solution.
- To ensure the highest optical performance and resolution, the projection lenses are specially treated with an anti-reflective coating, therefore, avoid touching the lens. To remove dust on the lens, use a soft dry cloth. For lens cleaning follow the instructions precisely as stipulated in the projector manual.
- Rated maximum ambient temperature,  $t_a = 40^\circ\text{C}$  ( $104^\circ\text{F}$ ).
- Rated humidity = 5% RH to 85% RH non-condensed.

### On servicing

- Do not attempt to service this product yourself, as opening or removing covers may expose you to dangerous voltage potentials and risk of electric shock.
- Refer all servicing to qualified service personnel.

- Attempts to alter the factory-set internal controls or to change other control settings not specially discussed in this manual can lead to permanent damage to the projector and cancellation of the warranty.
- Replacement parts: When replacement parts are required, be sure the service technician has used original Barco replacement parts or authorized replacement parts which have the same characteristics as the Barco original part. Unauthorized substitutions may result in degraded performance and reliability, fire, electric shock or other hazards. Unauthorized substitutions may void warranty.
- Safety check: Upon completion of any service or repairs to this projector, ask the service technician to perform safety checks to determine that the product is in proper operating condition.

## Malfunction unit

Remove all power from the projector and refer servicing to qualified service technicians under the following conditions:

- When the power cord or plug is damaged or frayed.
- If liquid has been spilled into the equipment.
- If the product has been exposed to rain or water.
- If the product does not operate normally when the operating instructions are followed. Adjust only those controls that are covered by the operating instructions since improper adjustment of the other controls may result in damage and will often require extensive work by a qualified technician to restore the product to normal operation.
- If the product has been dropped or the cabinet has been damaged.
- If the product exhibits a distinct change in performance, indicating a need for service.

## Safety Data Sheets for Hazardous Chemicals



For safe handling information on chemical products, consult the Safety Data Sheet (SDS). SDSs are available upon request via [safetydatasheets@barco.com](mailto:safetydatasheets@barco.com).

## On the reinforcement frame

- The Freya reinforcement frame is exclusively designed for the Freya projectors and can thus not be used on other equipment.
- The reinforcement frame is single use. While certain brackets on the frame can be removed in order to remove the front, rear and top cover of the projector, it is not allowed to disassemble the reinforcement frame itself.
- It is not allowed to stack the reinforcement frames of the Freya projector on top of each other, nor is it allowed to suspend them from each other.
- When the projector is suspended from a truss, a minimum of four (4) clamps must be used to secure the projector. The clamps must be fixed to the projector frame. Use a truss which is capable of handling five (5) times the complete load of the system. Also use clamps that are capable of handling five (5) times the complete load of the system.
- It is the responsibility of the installer to suspend the reinforcement frame in a safe and secure fashion. Safety cables must be applied according to local regulations and standards. Safety cables must be dimensioned for the applicable load and no drop distance is allowed or must be limited as much as possible.
- When the safety cables have undergone a heavy shock, invisible damage may have occurred to the safety cables. In this case the safety cables must be replaced.

# 1.4 Product safety labels

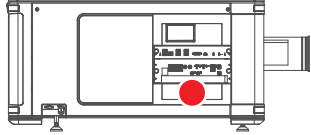
## Light beam related safety labels

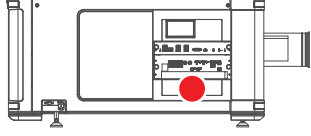
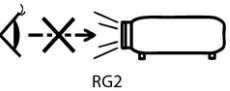
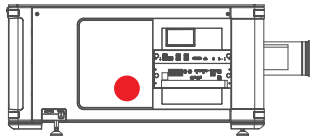
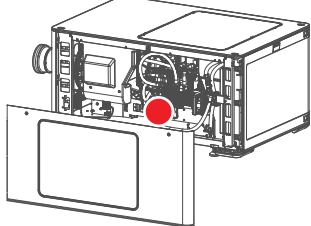
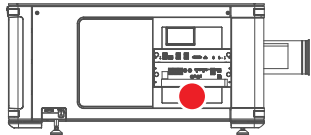

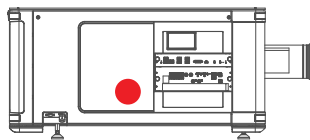
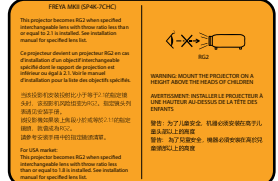
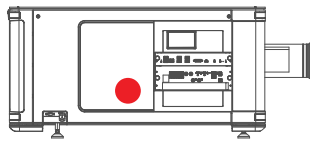
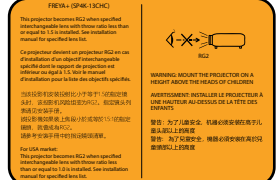
Label image	Label description	Label location
	Hazard RG3: optical radiation warning symbol	
	Hazard RG3: not for household use symbol	
	<p>CAUTION. Do not stare in to beam. RG2 product.</p> <p><b>WARNING: The RG2 throw ratio range is only valid when specified high contrast lenses are installed.</b></p> <p>See the specified lens list per projector model in the installation manual.</p>	
<div style="border: 2px solid black; padding: 5px;"> <p><b>DANGER</b> <b>危險</b></p> <p>CLASS 4 LASER RADIATION WHEN OPEN AVOID EYE OR SKIN EXPOSURE TO DIRECT OR SCATTERED RADIATION. RAYONNEMENT LASER DE CLASSE 4 EN CAS D'OUVERTURE EXPOSITION DANGEREUSE AU RAYONNEMENT DIRECT OU DIFFUS DES YEUX OU DE LA PEAU 打开时有4类激光辐射 避免眼或皮肤受到直射或散射辐射的照射</p> </div> <p>DANGER! CLASS 4 LASER RADIATION WHEN OPEN. AVOID EYE OR SKIN EXPOSURE TO DIRECT OR SCATTERED RADIATION.</p> <p>DANGER! RAYONNEMENT LASER DE CLASSE 4 EN CAS D'OUVERTURE. EXPOSITION DANGEREUSE AU RAYONNEMENT DIRECT OU DIFFUS DES YEUX OU DE LA PEAU.</p> <p>危险! 打开时有4类激光辐射。避免眼或皮肤受到直射或散射辐射的照射。</p>		
<p>WARNING! DO NOT LOOK INTO THE BEAM; NO DIRECT EYE EXPOSURE TO THE BEAM IS PERMITTED. RG3 IEC EN 62471-5:2015 CLASS 1 IEC EN 60825-1:2014. HAZARD DISTANCE: CONSULT SAFETY MANUAL.</p> <p>ATTENTION! NE PAS REGARDER LE FAISCEAU EVITER TOUTE EXPOSITION DIRECTE DES YEUX AU FAISCEAU. RG3 IEC EN 62471-5:2015 CLASS 1 IEC EN 60825-1:2014. DISTANCE DE SECURITE: CONSULTER LE MANUEL DE SECURITE</p> <p>警告! 勿观看光束 眼睛勿直接接触可允许暴露的光束 RG3 IEC EN 62471-5:2015 CLASS 1 IEC EN 60825-1:2014 危害距离: 请参考安全手册</p> <p>禁止直视光源 禁止眼睛暴露在光源照射範圍。雷射危險等級 RG3 IEC EN 62471-5:2015 CLASS 1 IEC EN 60825-1:2014 安全危害距離: 請參考安全手冊</p> <p>THIS PRODUCT IS IN CONFORMITY WITH PERFORMANCE STANDARDS FOR LASER PRODUCTS UNDER 21 CFR 1040, EXCEPT WITH RESPECT TO THOSE CHARACTERISTICS AUTHORIZED BY VARIANCE NUMBER 2018-V-2875 EFFECTIVE ON OCTOBER 2, 2018.</p>	<p>WARNING! DO NOT LOOK INTO THE BEAM; NO DIRECT EYE EXPOSURE TO THE BEAM IS PERMITTED. RG3 IEC EN 62471-5:2015 CLASS 1 IEC EN 60825-1:2014. HAZARD DISTANCE: CONSULT SAFETY MANUAL.</p> <p><a href="#">“Important safety instructions”, page 16</a></p> <p>THIS PRODUCT IS IN CONFORMITY WITH PERFORMANCE STANDARDS FOR LASER PRODUCTS UNDER 21 CFR 1040 EXCEPT WITH RESPECT TO THOSE CHARACTERISTICS AUTHORIZED BY VARIANCE NUMBER 2018-V-2875 EFFECTIVE ON OCTOBER 02, 2018.</p> <p>ATTENTION! NE PAS REGARDER LE FAISCEAU EVITER TOUTE EXPOSITION DIRECTE DES YEUX AU FAISCEAU. RG3 IEC EN 62471-5:2015 CLASS 1 IEC EN 60825-1:2014. DISTANCE DE SECURITE : CONSULTER LE MANUEL DE SECURITE</p> <p>警告! 勿观看光束 眼睛勿直接接触可允许暴露的光束 RG3 IEC EN 62471-5:2015 CLASS 1 IEC EN 60825-1:2014 危害距离: 请参考安全手册</p> <p>警告! 请勿注视光源。禁止眼睛暴露在光源照射範圍。雷射危險等級 RG3 IEC EN 62471-5:2015 CLASS 1 IEC EN 60825-1:2014 安全危害距離: 請參考安全手冊。</p>	

Label image	Label description	Label location
<p><b>FREYA MKII (SP4K-7CHC)</b></p> <p>This projector becomes RG2 when specified interchangeable lens with throw ratio less than or equal to 2.1 is installed. See manual for specified lens list</p> <p>Ce projecteur devient un projecteur RG2 en cas d'installation d'un objectif interchangeable spécifié dont le rapport de projection est inférieur ou égal à 2.1. Voir le manuel d'installation pour la liste des objectifs spécifiés.</p> <p>当该投影机安装投射比小于等于2.1的指定镜头时，该投影机风险组变为RG2。指定镜头列表请见安装手册。</p> <p>該投影機如果裝上焦段小於或等於2.1:1的鏡頭，就會成為RG2 請參考安裝手冊中的詳細相容鏡頭 清單</p> <p>For USA market: This projector becomes RG2 when specified interchangeable lens with throw ratio less than or equal to 1.8 is installed.</p> <p><b>WARNING: MOUNT THE PROJECTOR ON A HEIGHT ABOVE THE HEADS OF CHILDREN</b></p> <p><b>AVERTISSEMENT: INSTALLER LE PROJECTEUR À UNE HAUTEUR AU-DESSUS DE LA TÊTE DES ENFANTS</b></p> <p>警告：为了儿童安全，机器必须安装在高于儿童头部以上的高度</p> <p>警告：為了兒童安全，機器必須安裝在高於兒童頭部以上的高度</p>	 	
<p><b>FREYA+ (SP4K-13CHC)</b></p> <p>This projector becomes RG2 when specified interchangeable lens with throw ratio less than or equal to 1.5 is installed. See installation manual for specified lens list.</p> <p>Ce projecteur devient un projecteur RG2 en cas d'installation d'un objectif interchangeable spécifié dont le rapport de projection est inférieur ou égal à 1.5. Voir le manuel d'installation pour la liste des objectifs spécifiés.</p> <p>当该投影机安装投射比小于等于1.5的指定镜头时，该投影机风险组变为RG2。指定镜头列表请见安装手册。</p> <p>該投影機如果裝上焦段小於或等於1.5:1的鏡頭，就會成為RG2 請參考安裝手冊中的詳細相容鏡頭 清單</p> <p>For USA market: This projector becomes RG2 when specified interchangeable lens with throw ratio less than or equal to 1.0 is installed.</p> <p><b>WARNING: MOUNT THE PROJECTOR ON A HEIGHT ABOVE THE HEADS OF CHILDREN</b></p> <p><b>AVERTISSEMENT: INSTALLER LE PROJECTEUR À UNE HAUTEUR AU-DESSUS DE LA TÊTE DES ENFANTS</b></p> <p>警告：为了儿童安全，机器必须安装在高于儿童头部以上的高度</p> <p>警告：為了兒童安全，機器必須安裝在高於兒童頭部以上的高度</p>	 	

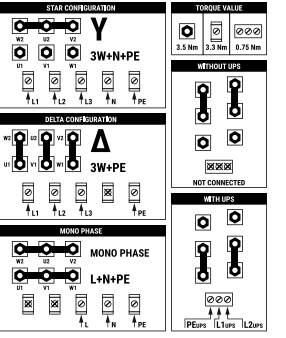
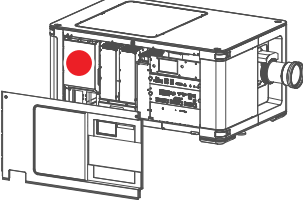

The use of a ceiling mount is recommended with this product to place it above the eyes of children.

## Electric related safety labels

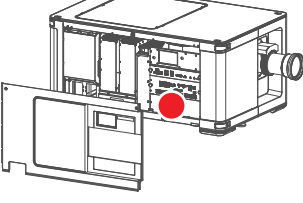
Label image	Label description	Label location
<p>Disconnect the power to the unit mains terminals and unplug power cord at UPS inlet before removing this cover. See ID-label for ratings.  <b>WARNING : HIGH LEAKAGE CURRENT EARTH CONNECTION ESSENTIAL BEFORE CONNECTING SUPPLY</b>                  SEE INSTALLATION INSTRUCTIONS BEFORE CONNECTING TO THE SUPPLY</p> <p>Déconnecter l'alimentation des bornes du réseau et déconnecter le câble de la prise UPS avant de retirer ce couvercle. Voir l'étiquette d'identification pour les paramètres.  <b>ATTENTION : COURANT DE FUITE ÉLEVÉ RACCORDEMENT À LA TERRE INDISPENSABLE AVANT LE RACCORDEMENT AU RÉSEAU</b>                  VOIR LA NOTICE D'INSTALLATION AVANT DE RACCORDER AU RÉSEAU</p> <p>在取下此外殼前，斷開投影機主電源端的電源並從UPS電源插座上拔下電源線。額定功率參閱產品標籤。  <b>警告：大漏電流，在接通電源之前必須先接地。</b>                  在連接電源前請查看安裝說明書</p> <p>在取下此外壳前，断开投影机主电源端的电源并从UPS电源插座上拔下电源线。额定功率参阅产品标签。  <b>警告：大漏电流，在接通电源之前必须先接地。</b>                  在连接电源前请查看安装说明书。</p> 	<p>Disconnect the power to the unit mains terminals and unplug power cord at UPS inlet before removing this cover. See ID-label for ratings.  <b>WARNING : HIGH LEAKAGE CURRENT EARTH CONNECTION ESSENTIAL BEFORE CONNECTING TO THE SUPPLY.</b></p> <p>Déconnecter l'alimentation des bornes du réseau et déconnecter le câble de la prise UPS avant de retirer ce couvercle. Voir l'étiquette d'identification pour les paramètres.  <b>ATTENTION : COURANT DE FUITE ÉLEVÉ RACCORDEMENT À LA TERRE INDISPENSABLE AVANT LE RACCORDEMENT AU RÉSEAU VOIR LA NOTICE D'INSTALLATION AVANT DE RACCORDER AU RÉSEAU</b></p> <p>在取下此外殼前，斷開投影機主電源端的電源並從UPS電源插座上拔下電源線。額定功率參閱產品標籤。  <b>警告：大漏電流，在接通電源之前必須先接地。</b>                  在連接電源前請查看安裝說明書</p> <p>在取下此外壳前，断开投影机主电源端的电源并从UPS电源插座上拔下电源线。额定功率参阅产品标签。  <b>警告：大漏电流，在接通电源之前必须先接地。</b>                  在连接电源前请查看安装说明书。</p>	 <p>Printed on Mains cover</p>
 <p><b>CAUTION</b>                  DOUBLE POLE / NEUTRAL FUSING                  HIGH RESIDUAL VOLTAGE -</p> <p><b>WARNING : RISK OF ELECTRIC SHOCK</b>                  SWITCH OFF AND UNPLUG BEFORE REMOVING THIS COVER</p> <p>SEE INSTRUCTIONS BEFORE REMOVING SMPS</p> <p><b>注意</b>                  兩極/中性熔斷                  高殘餘電壓</p> <p><b>警告：存在觸電風險</b>                  移除此蓋板之前，                  請先關機並拔掉電源插頭</p> <p>移除SMPS之前，請先閱讀說明</p> <p><b>ATTENTION</b>                  DOUBLE PÔLE / FUSIBLE SUR LE NEUTRE                  HAUTE TENSION RÉSIDUELLE -</p> <p><b>ATTENTION : RISQUE DE CHOCS ÉLECTRIQUES</b>                  ÉTEINDRE ET DÉCONNECTER AVANT                  OUVERTURE DU COUVERCLE</p> <p>LIRE LES INSTRUCTIONS AVANT DE RETIRER LE SMPS</p>	 <p>Printed on SMPS cover</p>	
<p><b>CAUTION! DOUBLE POLE / NEUTRAL FUSING HIGH RESIDUAL VOLTAGE - WARNING : RISK OF ELECTRIC SHOCK SWITCH OFF AND UNPLUG BEFORE REMOVING THIS COVER. SEE INSTRUCTIONS BEFORE REMOVING SMPS.</b></p> <p><b>注意 兩極/中性熔斷 高殘餘電壓. 警告：存在觸電風險 移除此蓋板之前，請先關機並拔掉電源插頭 移除SMPS之前，請先閱讀說明。</b></p> <p><b>ATTENTION DOUBLE PÔLE / FUSIBLE SUR LE NEUTRE HAUTE TENSION RÉSIDUELLE - ATTENTION : RISQUE DE CHOCS ÉLECTRIQUES. ÉTEINDRE ET DÉCONNECTER AVANT OUVERTURE DU COUVERCLE. LIRE LES INSTRUCTIONS AVANT DE RETIRER LE SMPS.</b></p>		

## 1.5 High Brightness precautions: Hazard Distance



### HD

Hazard Distance (HD) is the distance measured from the projection lens at which the intensity or the energy per surface unit becomes lower than the applicable exposure limit on the cornea or on the skin. The light beam is considered (to be) unsafe for exposure if the distance from a person to the light source is less than the HD.

## Restriction Zone (RZ) based on the HD

The HD depends on the amount of lumens produced by the projector and the type of lens installed. See chapter “HD in function of modifying optics”, page 26.

To protect untrained end users (as cinema visitors, spectators) the installation shall comply with the following installation requirements: Operators shall control access to the beam within the hazard distance or install the product at a height that will prevent spectators' eyes from being in the hazard distance. Radiation levels in excess of the limits will not be permitted at any point less than 2.0 meter (SH) above any surface upon which persons other than operators, performers, or employees are permitted to stand or less than 1.0 meter (SW) lateral separation from any place where such persons are permitted to be. In environments where unrestrained behavior is reasonably foreseeable, the minimum separation height should be greater than or equal to 3.0 meter to prevent potential exposure, for example by an individual sitting on another individual's shoulders, within the HD.

These values are minimum values and are based on the guidance provided in IEC 62471-5:2015 section 6.6.3.5.

The installer and user must understand the risk and apply protective measures based upon the hazard distance as indicated on the label and in the user information. Installation method, separation height, barriers, detection system or other applicable control measure shall prevent hazardous eye access to the radiation within the hazard distance.

For example, projectors that have a HD greater than 1 m and emit light into an uncontrolled area where persons may be present should be positioned in accordance with “the fixed projector installation” parameters, resulting in a HD that does not extend into the audience area unless the beam is at least 2.0 meter above the floor level. In environments where unrestrained behavior is reasonably foreseeable, the minimum separation height should be greater than or equal to 3.0 meter to prevent potential exposure, for example by an individual sitting on another individual's shoulders, within the HD. Sufficiently large separation height may be achieved by mounting the image projector on the ceiling or through the use of physical barriers.

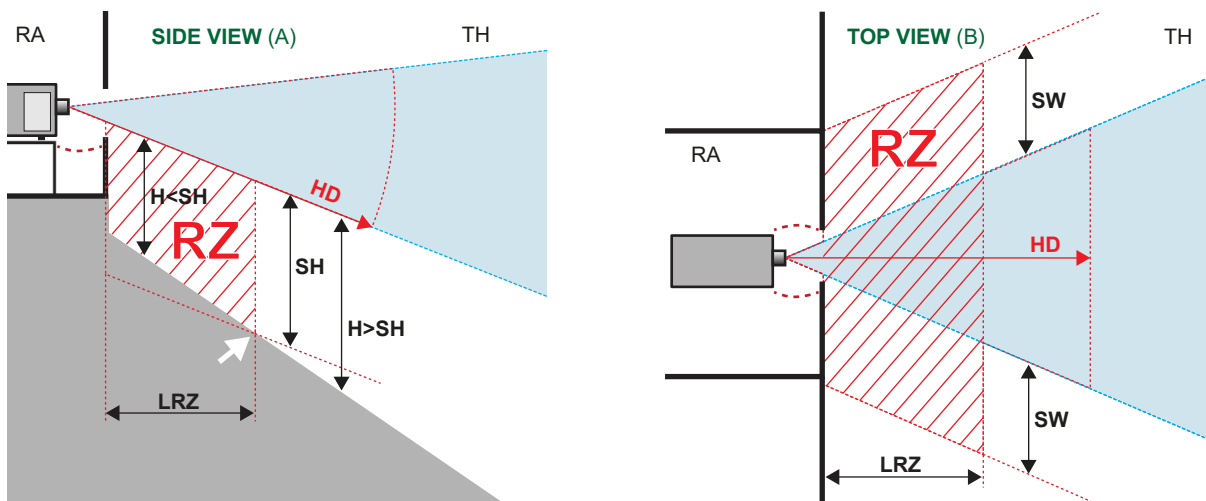

Image 1-1

- A** Side view
- B** Top view
- RA** Restricted Access location (boot area of projector).
- TH** Theater
- RZ** Restriction Zone in the theater

- HD** Hazard Distance
- LRZ** Length Restriction Zone in the theater
- H** Height between surface floor and the light beam
- SH** Separation Height
- SW** Separation Width

Based on national requirements, no person is allowed to enter the projected beam within the zone between the projection lens and the related hazard distance (HD). This shall be physically impossible by creating sufficient separation height or by placing barriers. The minimum separation height takes into account the surface upon which persons other than operator, performers or employees are permitted to stand.

On [Image 1-2](#) a typical setup is displayed. It must be verified if these minimum requirements are met. If required a restricted zone (RZ) in the theater must be established. This can be done by using physical barrier, like a red rope as illustrated in [Image 1-2](#).

The restricted area sticker can be replaced by a sticker with only the symbol.

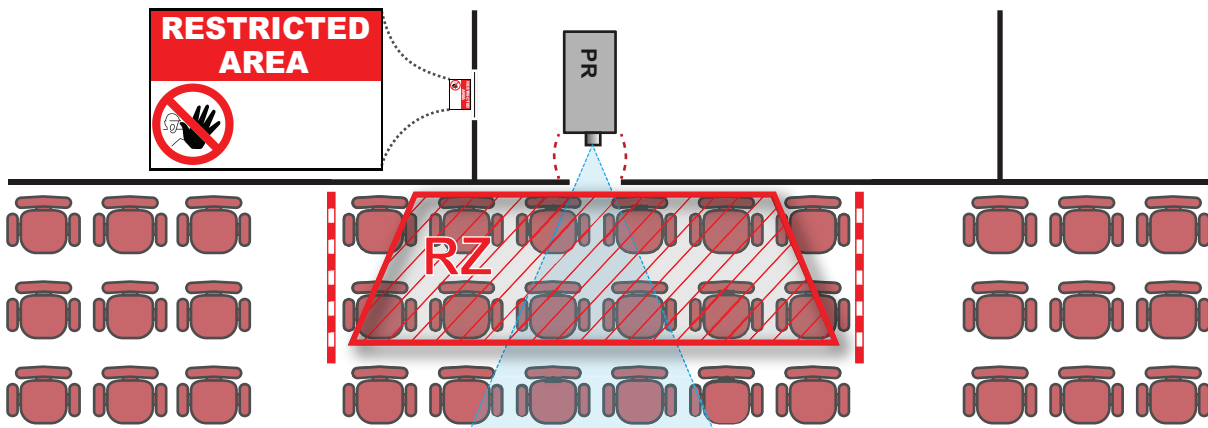

Image 1–2

## USA market

For LIPs (Laser Illuminated Projectors) installed in the USA market other restriction zone conditions apply.

LIPs for installation in restrained environment (cinema theaters, business rooms, class rooms, museums ...) shall be installed at height vertically above the floor such that the bottom plane of the hazard distance zone shall be no lower than 2.5 meters above the floor. Horizontal clearance to the hazard distance zone shall be not less than 1 meter. Alternatively, in case the height of the separation barrier for the horizontal clearance is at least 1 meter high then the horizontal clearance (SW) can be reduced to:

- 0 meter if the height of the hazard zone is minimum 2.5 meter.
- 0.1 meter if the height of the hazard zone is minimum 2.4 meter.
- 0.6 meter if the height of the hazard zone is minimum 2.2 meter.

LIPs for installations in unrestrained environment (concerts, ...) shall be installed at a height vertically above the floor such that the bottom plane of the Hazard distance Zone shall be no lower than 3 meters above the floor. Horizontal clearance to the hazard distance zone shall be not less than 2.5 meters. Any human access horizontally to the Hazard Zone, if applicable, shall be restricted by barriers. If human access is possible in an unsupervised environment, the horizontal or vertical clearances shall be increased to prevent exposure to the hazard distance zone.

The LIP shall be installed by Barco or by a trained and Barco-authorized installer or shall only be transferred to laser light show variance holders. This is applicable for dealers and distributors since they may need to install the LIP (demo install) and/or they transfer (sell, rent, lease) the LIP. Dealers and distributors shall preserve sales and installation records for a period of 5 years. Variance holders may currently hold a variance for production of Class IIIB and IV laser light shows and/or for incorporating RG3 LIPs. Laser light show variance for RG3 LIPs can be requested by mailing the application to [RadHealthCustomerService@fda.hhs.gov](mailto:RadHealthCustomerService@fda.hhs.gov).

The installation checklist for laser illuminated RG3 projectors must be fully completed after the installation. The installation checklist can be downloaded from the Barco website. The installer shall preserve the checklist for a period of 5 years.

Install one or more readily accessible controls to immediately terminate LIP projection light. The power input at the projector side is considered as a reliable disconnect device. When required to switch off the projector, disconnect the power cord at the projector side. In case the power input at the projector side is not accessible (e.g. truss mount), the socket outlet supplying the projector shall be installed nearby the projector and be easily accessible, or a readily accessible general disconnect device shall be incorporated in the fixed wiring.

## 1.6 HD for fully enclosed projection systems

### HD



Hazard Distance (HD) is the distance measured from the projection lens at which the intensity or the energy per surface unit becomes lower than the applicable exposure limit on the cornea or on the skin. The light beam is considered (to be) unsafe for exposure if the distance from a person to the light source is less than the HD.



## Restriction Zone (RZ) based on the HD

The projector is also suitable for rear projection applications; projecting a beam onto a diffuse coated projection screen. As displayed in [Image 1–3](#) two areas should be considered: the restricted enclosed projection area (RA) and the observation area (TH).

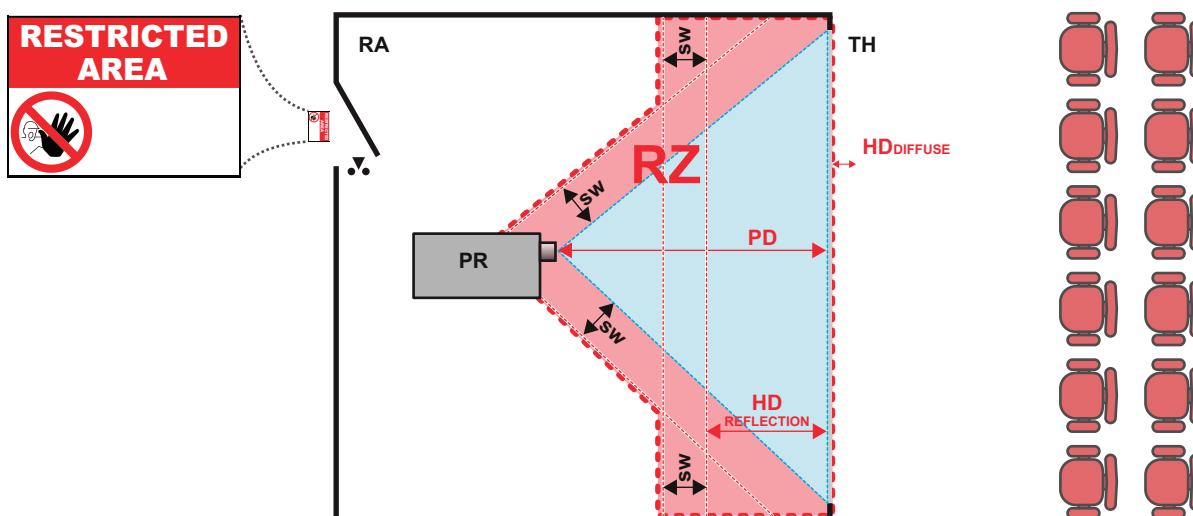

Image 1–3

- |  |  |
|--|--|
| <b>RA</b> Restricted Access location (enclosed projection area). | <b>RZ</b> Restriction Zone.                          |
| <b>PR</b> Projector.   | <b>PD</b> Projection Distance.                       |
| <b>TH</b> Theater (observation area).                            | <b>SW</b> Separation Width. Must be minimum 1 meter. |

For this type of setup 3 different HD shall be considered:

- HD as discussed in “[High Brightness precautions: Hazard Distance](#)”, page 22, relevant for intrabeam exposure.
- HD<sub>reflection</sub> : the distance that has to be kept restrictive related to the reflected light from the rear projection screen.
- HD<sub>diffuse</sub> : the relevant distance to be considered while observing the diffuse surface of the rear projection screen.

As described in “[High Brightness precautions: Hazard Distance](#)”, page 22, it is mandatory to create a restricted zone within the beam areas closer than any HD. In the enclosed projection area the combination of two restricted zones are relevant: The restricted zone of the projected beam toward the screen; taking into account 1 meter Separation Width (SW) from the beam onward. Combined with the restricted zone related to the rear reflection from the screen (HD<sub>reflection</sub>); also taking into account a 1 meter lateral separation.

The HD<sub>reflection</sub> distance equals 25% of the difference between the determined HD distance and the projection distance to the rear projection screen. To determine the HD distance for the used lens and projector model see chapter “[HD in function of modifying optics](#)”, page 26.

$$HD_{\text{reflection}} = 25\% (HD - PD)$$

The light emitted from the screen within the observation shall never exceed the RG2 exposure limit, determined at 10 cm. The HD<sub>diffuse</sub> can be neglected if the measured light at the screen surface is below 5000 cd/m<sup>2</sup> or 15000 LUX.

# 1.7 HD in function of modifying optics

## Hazard Distance

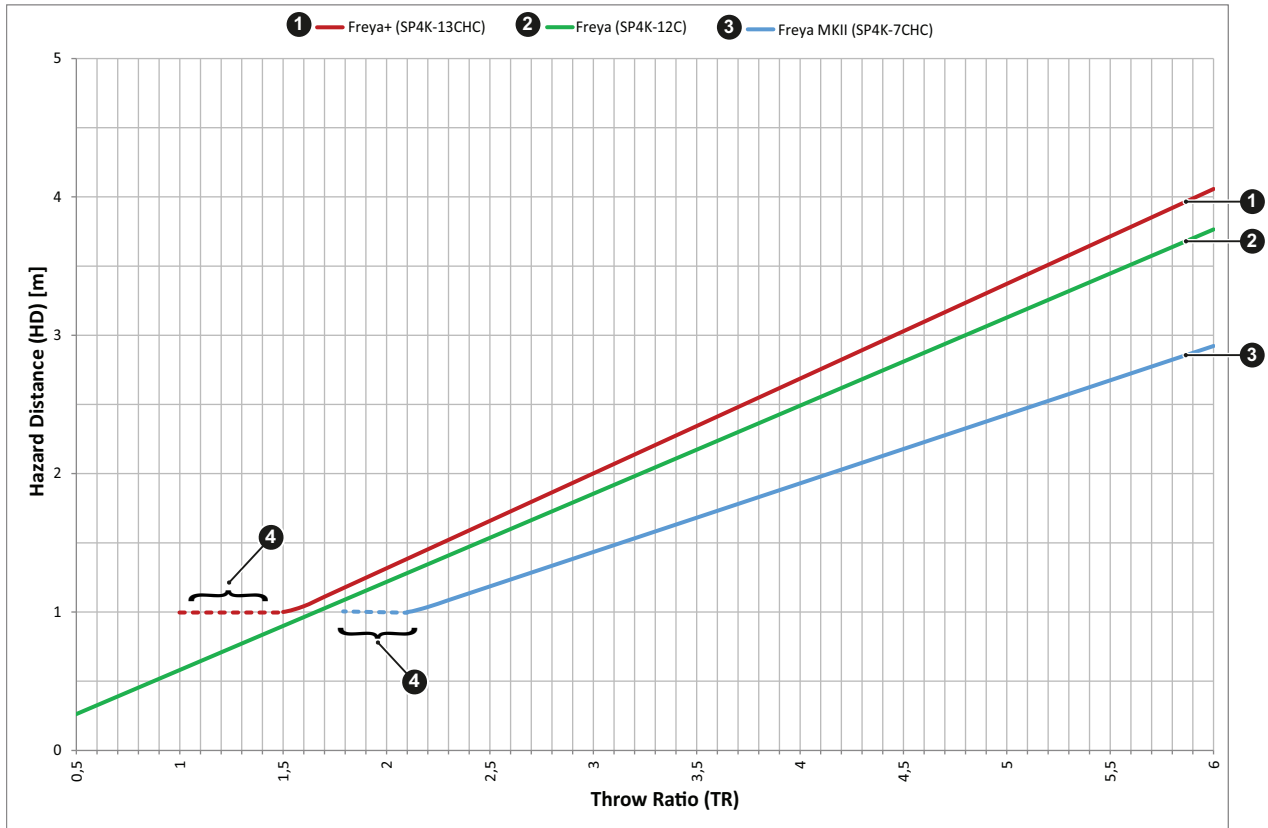

Image 1–4

- 1** Freya+ (SP4K-13CHC)
- 2** Freya (SP4K-12C)
- 3** Freya MKII (SP4K-7CHC)
- 4** Horizontal part of the curve is only applicable for USA market (FDA Laser Notice No. 57, dated May 8, 2019)
- HD** Hazard Distance
- TR** Throw Ratio



The Freya MKII is the successor of the Freya. Freya MKII has adaptations to the internal lightpath to achieve higher contrast. It is not possible to rebuild a Freya to a Freya MKII.

# Getting started

# 2

2.1	Explaining the power states .....	28
2.2	Switching the projector ON .....	30
2.3	Connecting to the projector for the first time .....	31
2.4	Switching the projector OFF .....	32
2.5	Operation in 24/7 Mode .....	33
2.6	Web Communicator .....	34
2.7	Web Commander .....	34

## Physical installation

Instructions for the physical installation of this projector are not included in this document (User Guide) . For physical installation instructions (e.g. positioning, cooling, electrical connection ... ) see installation manual of the projector.

## How to control the projector ?

The projector can be controlled by the local touch screen, via General Purpose inputs and outputs or by browser application.

## 2.1 Explaining the power states

### Power states explained

The projector can have one of several power states, which you can recognize by the state of the power LED.

Projector Power State	Behavior	Power LED
Mains power off	Projector is not powered	Off
OFF mode	The power button and GPI3 are powered (for remote power-on).	Slowly blinking RED
ECO mode	Projector IP connection is active; touch display and image processing are off.	Full RED
READY mode	Projector is fully powered and active; touch display is on (if available), Web Communicator is active and light is OFF.	Full GREEN
ON mode	Projector is fully powered and active; touch display is on (if available), Web Communicator is active and light is ON.	Full GREEN
Going to ECO mode	Turning electronics and light source OFF.	Blinking green

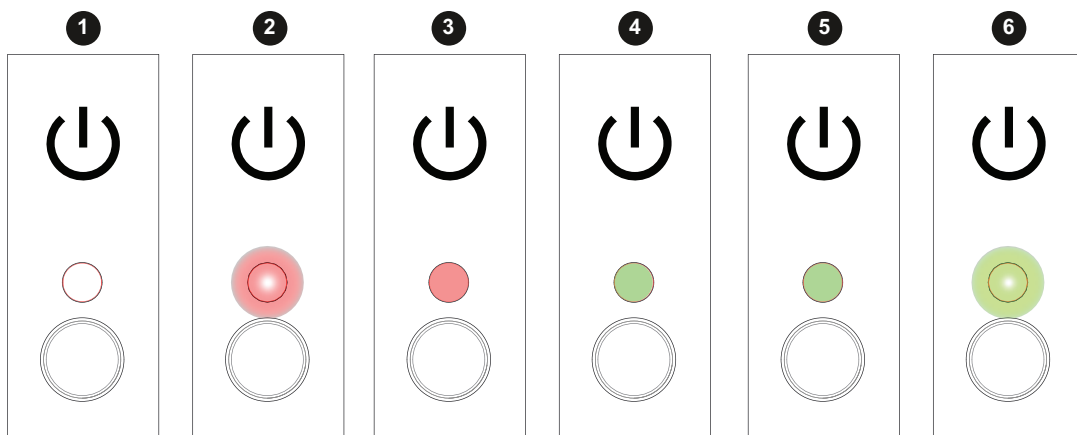

Image 2-1

- 1 Mains power off
- 2 OFF mode
- 3 ECO mode

- 4 READY mode
- 5 ON mode
- 6 Going to ECO mode

### Switching between power states

You can change power state by using one of the following options:

- Pressing the Power button on the Cinema Controller (reference 1)
- Sending a wake-up signal to the GPI3 input for more than 0.5 seconds, but less than 2 (reference 2).<sup>1</sup>
- Using the *ECO* menu on the touch display (if available).
- Using the *Power* menu in Web Communicator.

1. GPI3 works the same way as the power button. Thus take into account that sending a signal for more than 6 seconds will turn the projector OFF instead.

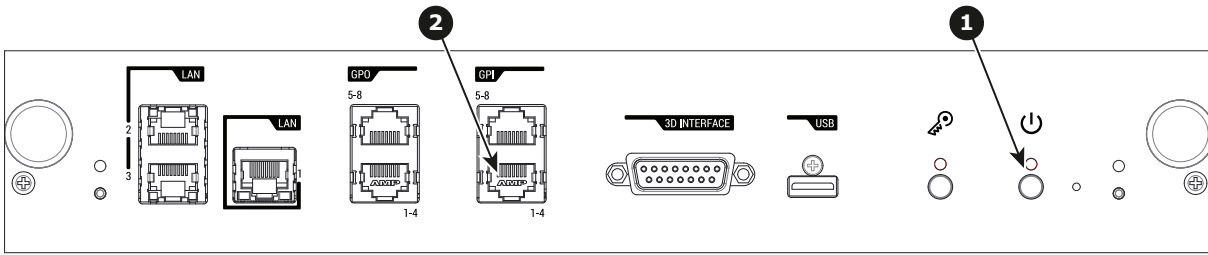

Image 2-2 Location of the Power button and GPI 1-4 input on the Cinema Controller.

### Power state diagram

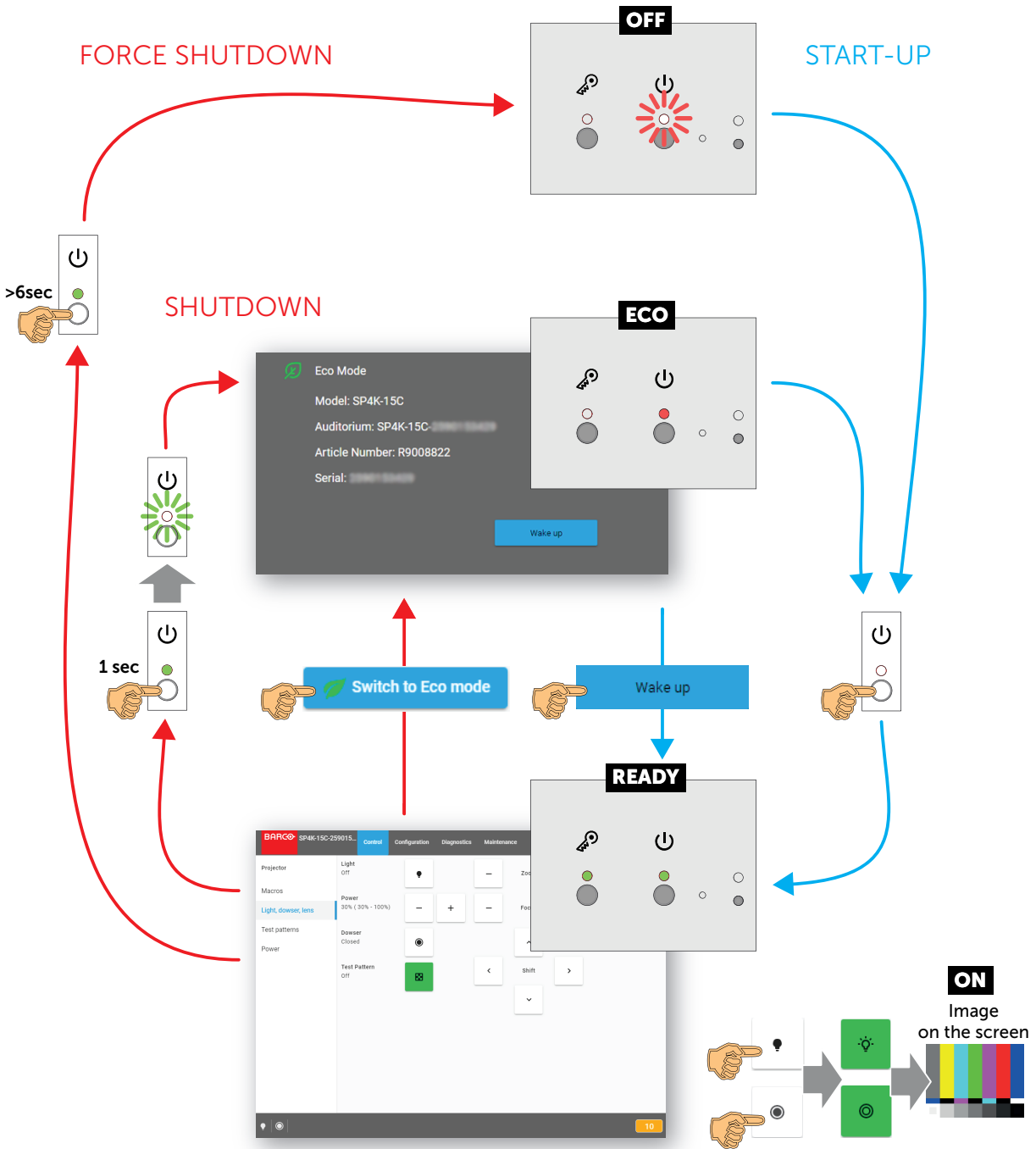

Image 2-3 Power State diagram

## 2.2 Switching the projector ON

### Possible ways to switch on

There are multiple ways to switch on the projector, depending on a few factors:

Current Power Stage	How to power on	Notes
OFF	<ul style="list-style-type: none"> <li>Locally, using the power button</li> <li>Remotely, using GPI3</li> </ul>	After the projector is powered, you can further access the projector using either Web Communicator or the optional touch display.
ECO mode	<ul style="list-style-type: none"> <li>Locally, using the power button and touch display<sup>2</sup></li> <li>Remotely, using Web Communicator</li> <li>Remotely, using GPI3</li> </ul>	Take into account that the Web Communicator method can only be used when the projector is in ECO mode.

### How to switch on locally, using the touch display?

1. Ensure that the Freya projector is installed onto a stable platform.
2. Ensure the projector is correctly connected to the mains power.
3. Ensure that the correct lens is installed for your application.
4. Press the power button to switch the projector ON.  
The projector will start up and the touch display will start its initialization procedure.
5. Wait until the *Projector control* menu is fully accessible on the touch display.  
 *Tip:* While the menu may become accessible early on, certain icons (e.g. the Light button) may be greyed out until the projector is ready to play.



Image 2-4 Example of the Projector control menu on the touch display.

6. Press the **Light** button to activate the light source. Use a press of >1 second.  
The Light source will prepare itself for playing, by doing a laser self-test. This may take a while, depending on your projector variant. While the light source is turning on, the Light button will blink green. Once completed it will be full green.
7. Press the **Dowser** button to open the dowser.

2. Only possible if the Touch Display option has been chosen.

## How to switch on remotely, using only Web Communicator?

1. Ensure that the Freya projector is installed onto a stable platform.
2. Ensure the projector is correctly connected to the mains power.
3. Ensure that the correct lens is installed for your application.
4. Browse to the IP address of the projector, using the http protocol.

With the projector in ECO mode, you will be redirected to the ECO mode page.

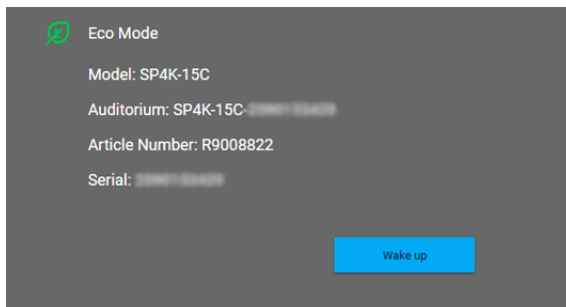

Image 2–5 Example of the Eco Mode page in Web Communicator

5. On the Eco mode page, press **Wake up**.  
The projector will start up. Once it has fully started up, you will be redirected to the login page of Web Communicator.
6. Once the login page becomes available, log in to the projector.  
Once logged in, you will be redirected to the *Light, dowser, lens* menu.
7. In this menu, press the **Light** button to activate the light source. Use a press of >1 second.  
The Light source will start warming up.
8. Press the **Dowser** button to open the dowser.

## How to switch on remotely, using only GPI3?

1. Ensure that the Freya projector is installed onto a stable platform.
2. Ensure the projector is correctly connected to the mains power.
3. Ensure that the correct lens is installed for your application.
4. Ensure that the GPI port is connected to a supported automation controller (e.g. a JNIOR device).
5. Send a signal to GPI3 for more than 0.5 seconds (but less than six seconds).



*Tip:* GPI3 works in a similar fashion to the power button. So sending a signal for six seconds or more will force the projector OFF instead.



**CAUTION:** See the User Guide of the projector to operate and control the projector.

## 2.3 Connecting to the projector for the first time

### Default settings

If you want to access Web Communicator, take into account the following default settings of the projector. By default you will be able to access Web Communicator using the following default settings.

Item	Setting
IP address	192.168.100.2
Subnet mask	255.255.255.0
Default gateway	192.168.100.1
Default hostname	[projector model] - [serial number]

## How to connect?

1. On the touch display of the projector, press either *About*, or *Settings* to see the IP address assigned to the projector.
2. Use a web browser to browse to the assigned IP address.  
The login page of Web Communicator will be displayed.
3. Log in onto Web Communicator.

## Default passwords Web Communicator

When logging in for the first time, use one of the following default passwords

User group	User name projector	Default password	User name ICMP	Default password
Administrator	admin	Admin1234	admin	Admin1234
Service technician	st	Service1234		
Show manager	show	Show1234	show	Show1234
Projectionist			proj	Proj1234



For security reasons, it is advised to change these passwords as soon as possible after your projector has been configured.

## 2.4 Switching the projector OFF



Putting the projector in ECO mode is the preferred method of shutting down the projector after a day of playing. Only switch the projector to OFF if technical problems have occurred. Take into account that you can **not** start the projector remotely when the projector has been switched OFF. You can only power it using the power button.

### How to put the projector in ECO mode, using the touch display?

1. In the main menu of the touch display, press on the ECO button.

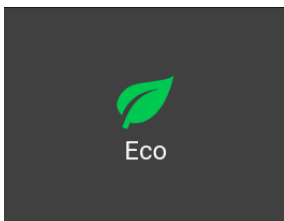

Image 2-6

2. In the Eco menu, press "Switch to ECO mode". Press for more than one second.



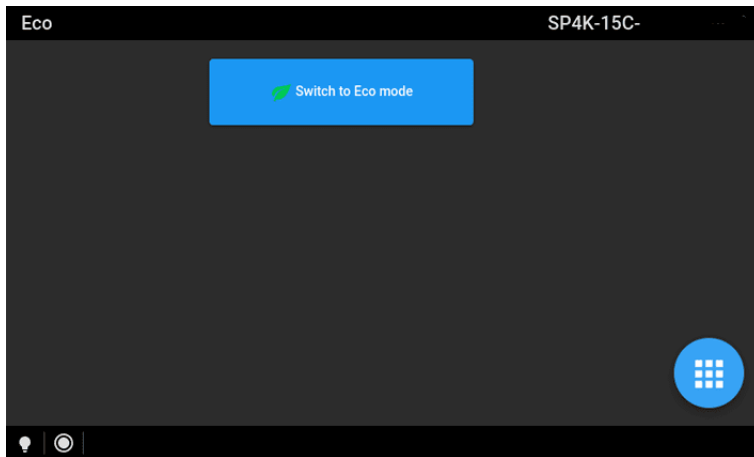

Image 2-7 Example of the ECO menu on the touch display

## How to put the projector in ECO mode, using the Web Communicator?

1. In the Communicator, browse to *Control* >> *Power*.
2. In the Power menu, press **Switch to ECO mode** and confirm.

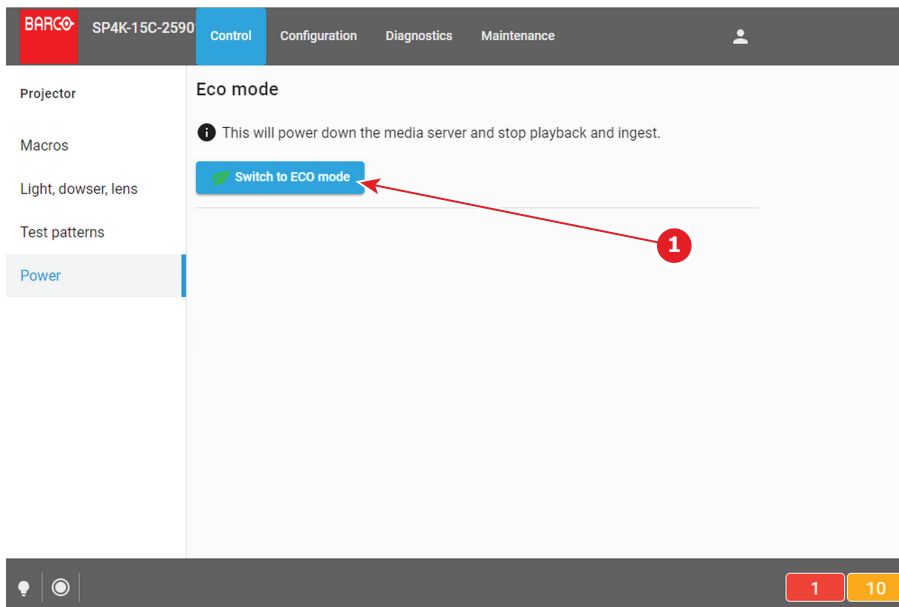

Image 2-8

## How to turn the projector OFF?

1. Press the power button for more than six seconds. The projector will go to OFF mode.
- or
- Send a signal via GPI3 for more than six second. The projector will go to OFF mode.

## 2.5 Operation in 24/7 Mode

### General

When the projector is destined to be operated continuously 24 hours a day, 7 days a week, the following recommendations should be followed:

- Twice a day, switch off the projector during two minutes by using the power button. The power down action will automatically and invisibly trigger a grey test pattern running within the projector.

- Apply moving video content as much as possible, with on average a level of 50% white (long-term use of extreme black or white content could potentially cause accelerated aging).

## 2.6 Web Communicator

### Built-in web application

The Web Communicator application is a uniquely powerful and easy to use built-in web application for the Barco projector. This application provides all the necessary tools necessary to setup and control the connected projector. A comprehensive array of easy to access menu pages provide the projectors digital input, output and screen display via a combination of simple buttons and displays.

The Web Communicator user interface is readily available on the projector without any additional software installation. It is accessible via a web browser and is fully supported on iOS and Android devices.



While all web browsers are supported, the recommended browser is Chrome.

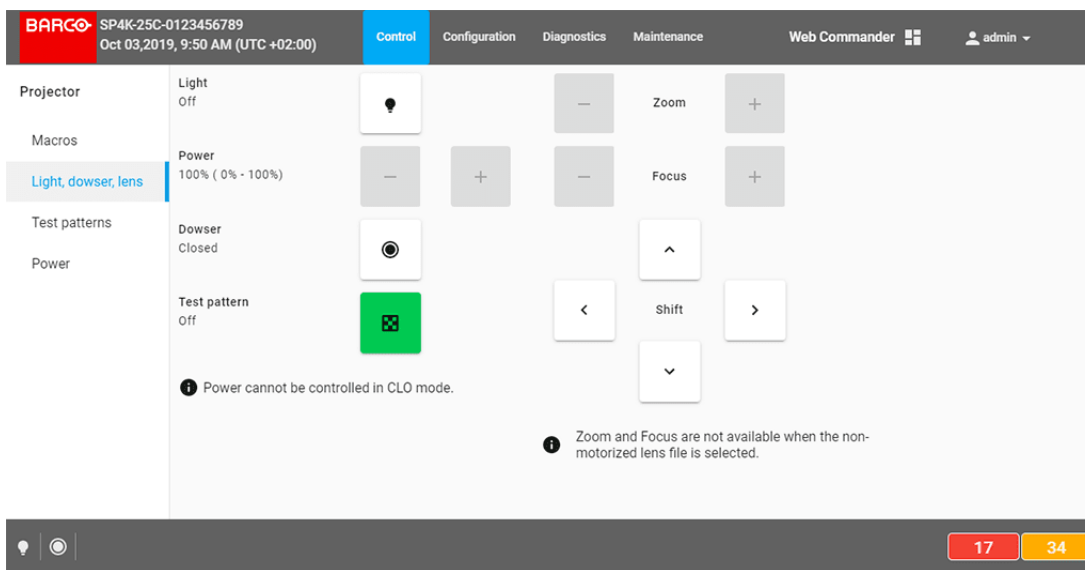

Image 2–9 Example of the Web Communicator tool

### Quick and Easy configuration

Clearly indicated tab pages allow the control of Projector connection, configuration, test, color calibration and configuration with an existing automation system. All actions can be activated by a simple click. Depending on the user level, functions are enabled or disabled in the application. The enabled functions are only accessible via a password entry and that prevents misalignment once everything is correctly aligned.

## 2.7 Web Commander

### Web Commander

All Barco Alchemy projectors come with the 'Barco Web Commander' screen management system featuring an intuitive user interface for simple operation.

The Barco Alchemy projectors have been carefully designed to greatly increase the level of operational efficiency. Projectionists can enjoy a streamlined and intuitive user interface that seamless blends projector control with a full-fledged screen management system. The 'Barco Web Commander' user interface is readily available on the projector without any additional software installation. It is accessible via a web browser and is fully supported on iOS and Android devices.

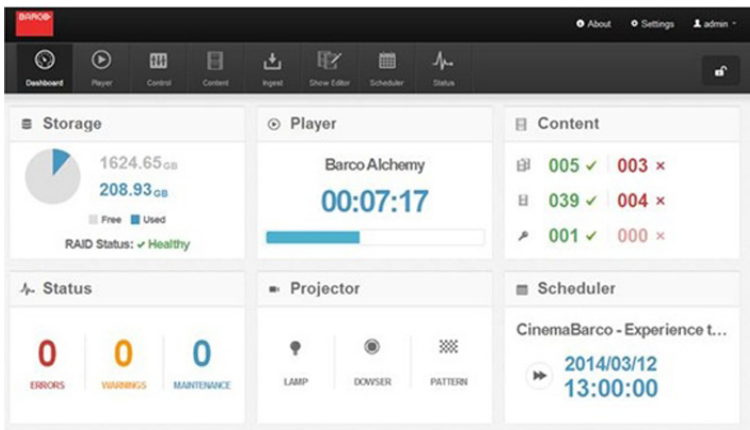

Image 2-10



The Web Commander has its own user guide, of which you can find the latest version on the Barco website.



# ICMP-X

# 3

3.1	ICMP-X configuration via Web Communicator .....	38
3.2	ICMP-X status LEDs .....	38
3.3	HDD status LEDs .....	39
3.4	Removing a HDD from the ICMP-X .....	41
3.5	Installing a HDD into the ICMP .....	42
3.6	ICMP-X reset .....	44

## About this chapter

This chapter describes the actions a user is allowed to do with the ICMP-X. This includes configuring the ICMP-X, removing and installing HDDs, resetting the ICMP-X and checking the status lights.

For the specifications on the SDI and HDMI ports, please refer to the appendices.



Image 3-1

## 3.1 ICMP-X configuration via Web Communicator

### About ICMP-X configuration

Following parameters are available to configure the ICMP-X:

- Global settings: allows defining name of the ICMP-X, host name (network identifier) and IP address which can be used for communication with external content devices.
- User settings: definition of all users allowed on the ICMP-X.
- Server settings: definition of access to servers and storage libraries of content (movies, KDM, etc.).
- Player settings: Audio delay and audio output frequency.
- Audio channel: allows defining the mapping of audio channels (content) on each audio output (AES outputs of the ICMP-X.).
- Scheduler setting: Enable/Disable scheduler at startup, delays allowed in scheduler mode and length of schedule history.
- Devices: allows defining communication ports settings, to access external devices controlled by the automation.
- Automation Cues: event cues that are triggered from different sources and to which can be assigned actions to be executed by the automation engine.
- Verify internal clock of the ICMP-X.



All installation and maintenance operations on the ICMP-X are performed via Web Communicator, the Barco configuration software. Please refer to the user guide for further information.

### About Default settings

The restore of factory setting is a feature that allows removing all settings performed on the ICMP-X and replaces them with the default values set at the factory. Please refer to the Communicator user guide for further information.

### About the ICMP-X internal clock

The crystal on the ICMP-X board that manages the clock shows a certain drift (all crystals do). With the Communicator the internal clock can be adjusted. This maintenance action should be repeated every 3 months. When neglected the system will lock up.

It is possible to enable NTP (Network Time Protocol). You have to configure (at installation) an IP address where the ICMP-X can find a sync signal. From then on, and as long as the connection is active, the ICMP-X will automatically keep its clock correct. For detailed instructions see user guide.

## 3.2 ICMP-X status LEDs

### ICMP-X status LEDs and Reset button

LEDs on ICMP-X front panel give information on the status of the device.

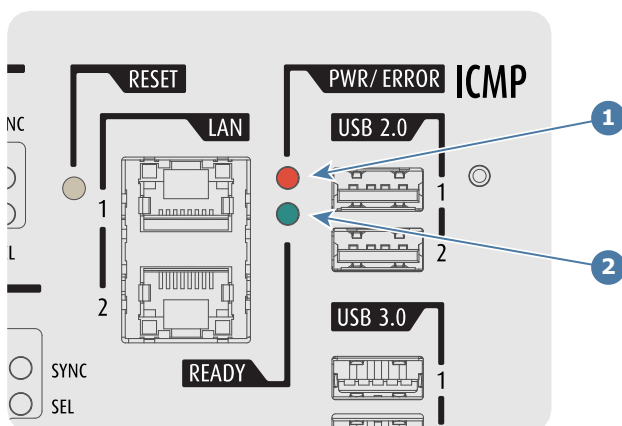

Image 3-2

- 1 Power / Error LED
- 2 Ready LED

Status overview PWR/ERROR and READY LEDs:

PWR/ERROR	READY	ICMP-X Status
Off	Off	Turned off
Red	Off	Board reset or FIPS error
Blinking Green	Off	Boot loader
Blinking Green	Blinking Orange	Operating System start up
Blinking Green	Orange	Security Manager - Image Integrity tests
Blinking Green	Blinking Yellow	Security Manager - Self Test
Blinking Green	Yellow	Security Manager - FPGA self-test
Green	Blinking Green	Starting Applications
Green	Green	Applications started in normal mode
Green	Orange	Applications started in degraded mode
Blinking Red	Off	FIPS error
Green	Blinking Orange	Update ongoing
Orange	Orange	Update done

### 3.3 HDD status LEDs

#### HDD status LEDs

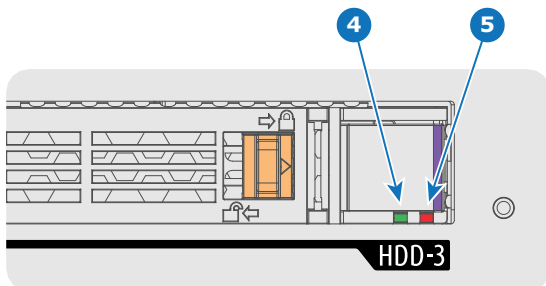

Image 3-3

- 4 HDD I/O LED
- 5 RAID LED

#### Status LEDs on ICMP-X

HDD I/O	RAID	HDD Status
Off	Off	HDD idle / disk in RAID OK.
Blinking green	Off	HDD I/O activity / disk in RAID OK.
Blinking green	Slow blinking red	HDD disks not (yet) initialized (not supported on ICMP with GEN1 storage controller).
Blinking green	Fast blinking red	HDD I/O activity / RAID rebuilding.
Off	Red	HDD idle / Disk error. Consult the following troubleshooting table for curative actions.



When entering a new HDD in an ICMP-X, the HDD RAID LED will be full red for a short time. This is not an error, the HDD has not yet been “recognized” by the projector and ICMP-X.

Once the HDD has been accepted by the ICMP-X, the full red LED will start blinking in accordance with the previous status table.

If the LED remains full red, an error has occurred. In this case, consult the following troubleshooting table for curative actions.

## Troubleshooting

Situation	Solution
<p>One disk failed (red LED) + <b>RAID degraded</b>. The ongoing event is not interrupted.</p> <p><b>Note:</b> The disk status (RAID degraded) can be retrieved via the (Web) Commander. See user guide of the (Web) Commander.</p>	<ol style="list-style-type: none"> <li>1. Switch off the power.</li> <li>2. Replace the defect HDD with approved model of the same storage capacity. See procedure <a href="#">“Removing a HDD from the ICMP-X”, page 41</a>, and <a href="#">“Removing a HDD from the ICMP-X”, page 41</a>. Ensure to insert the HDD firmly.</li> <li>3. Switch on the power.</li> </ol> <p><b>Result:</b> As soon the new HDD is detected by the ICMP-X the rebuild of the RAID is started (Blinking red LED).</p>
<p>One disk failed (red LED) + Error 10580 “<b>local storage not available</b>”.</p> <p><b>Note:</b> The disk status (Error code) can be retrieved via the (Web) Commander. See user guide of the (Web) Commander.</p>	<ol style="list-style-type: none"> <li>1. Switch off the power.</li> <li>2. Replace the defect HDD with approved model of the same storage capacity. See procedure <a href="#">“Removing a HDD from the ICMP-X”, page 41</a>, and <a href="#">“Removing a HDD from the ICMP-X”, page 41</a>. Ensure to insert the HDD firmly.</li> <li>3. Switch on the power.</li> </ol> <p><b>Result:</b> As soon the new HDD is detected by the ICMP-X the rebuild of the RAID is started (Blinking red LED).</p>
<p>Multiple disks failed (multiple red LEDs) + Error 10573 “<b>The RAID is broken</b>”.</p> <p><b>Note:</b> The disk status (RAID broken) can be retrieved via the (Web) Commander. See user guide of the (Web) Commander.</p>	<ol style="list-style-type: none"> <li>1. Switch off the power.</li> <li>2. Replace all defect HDDs with approved models of the same storage capacity. See procedure <a href="#">“Removing a HDD from the ICMP-X”, page 41</a>, and <a href="#">“Removing a HDD from the ICMP-X”, page 41</a>. Ensure to insert the HDDs firmly.</li> <li>3. Switch on the power.</li> <li>4. Start “RAID Initialize”. See user guide of the (Web) Communicator.</li> </ol> <p><b>Result:</b> a new empty RAID is created.</p>



**Situation**

A set of HDDs initialized for a GEN 2 storage controller is installed on a GEN 1 storage controller (All red LEDs remain off) + Combination of three errors (10580 “**local storage not available**”, 10585 “**storage mount failed**”, 10573 “**the RAID is broken**”)

**Note:** The disk status (Error code) can be retrieved via the (Web) Commander. See user guide of the (Web) Commander.

All HDD LEDs remain off + Error 10580 “**local storage not available**”.

**Note:** The disk status (Error code) can be retrieved via the (Web) Commander. See user guide of the (Web) Commander.

**Solution**

1. To avoid any misidentification, double check ICMP model and if HDD model is compatible with installed storage controller (see list of HDD models validated by Barco).
2. Start “RAID Initialize”. See user guide of the (Web) Communicator. Note that all content will be lost!

**Result:** a new empty RAID is created.

1. Switch off the power.
2. Reseat all HDDs. See procedure “[Removing a HDD from the ICMP-X](#)”, page 41, and “[Removing a HDD from the ICMP-X](#)”, page 41. Ensure to insert the HDDs firmly.
3. If problem remains try “RAID Initialize”. See user guide of the (Web) Communicator. Note that all content will be lost!
4. If problem remains contact Service for further instructions.



In case the ICMP-X has to be returned to factory (e.g. for repair) the non defective HDDs should be removed and kept.

## 3.4 Removing a HDD from the ICMP-X



In case the ICMP-X has to be returned to factory (e.g. for repair) the non defective HDDs should be removed and kept.

### How to remove a HDD ?

1. Switch off the projector.
2. Moving the latch towards the left.

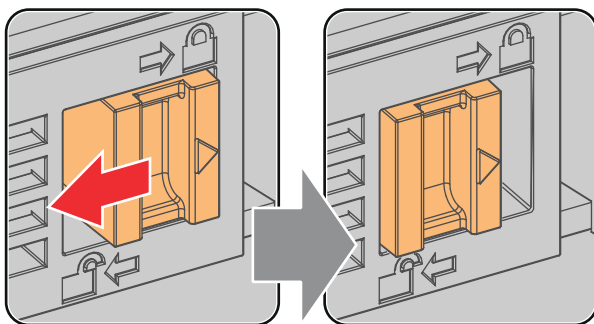

Image 3-4

3. Push the unlock button to open the handle.

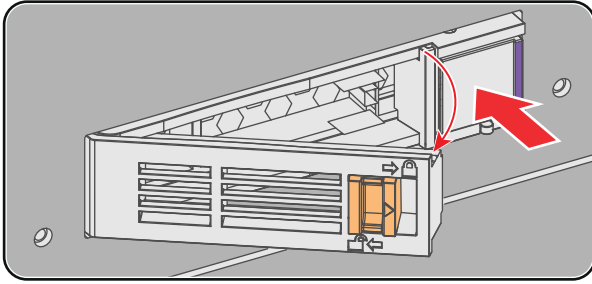

Image 3-5

4. Pull the HDD out of its slot.

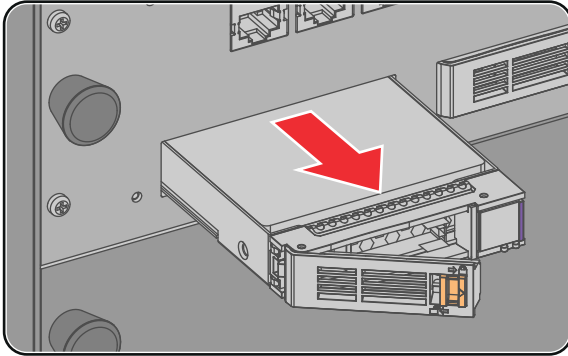

Image 3-6



To install an HDD, see the following procedure: [“Removing a HDD from the ICMP-X”, page 41.](#)

## 3.5 Installing a HDD into the ICMP



This procedure assumes that the HDD slot of the ICMP is empty. If not, see procedure [“Removing a HDD from the ICMP-X”, page 41.](#)



**CAUTION:** Always use a new empty spare part HDD approved by Barco to replace a malfunction HDD. Do not use a HDD from another ICMP HDD set.



**CAUTION:** Always make sure that all HDDs in the ICMP HDD set have the same storage capacity. See label on top of the HDD to know the storage capacity.

### How to install a HDD ?

1. Ensure that the projector is switched off.
2. Prepare the HDD for insertion by moving the latch towards the left and push the unlock button to open the handle.

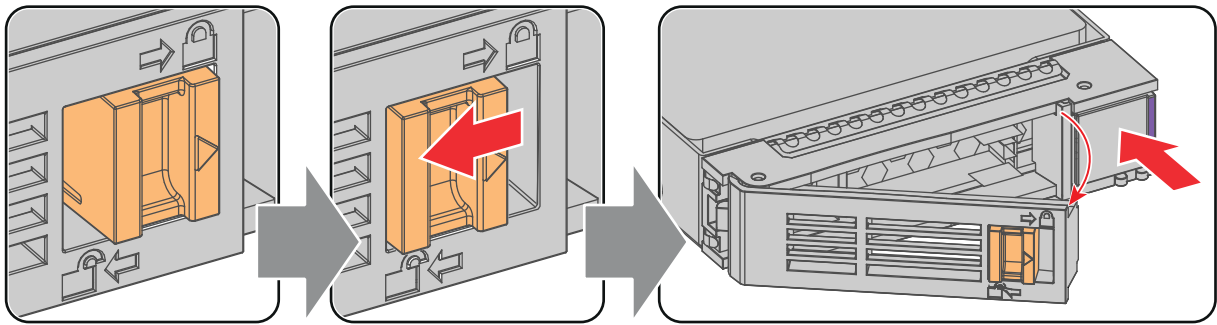

Image 3-7

3. Insert the HDD into the HDD slot. Ensure that the handle is sufficiently open so that the hook (reference 1) of the handle can pass the front plate of the ICMP

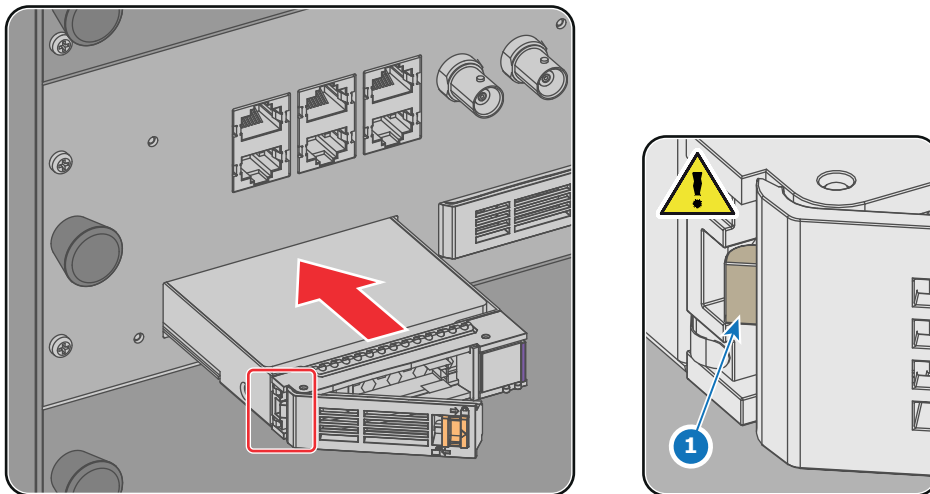

Image 3-8

4. Push the HDD completely and firmly inside its slot, close the handle, and move the latch towards the right.

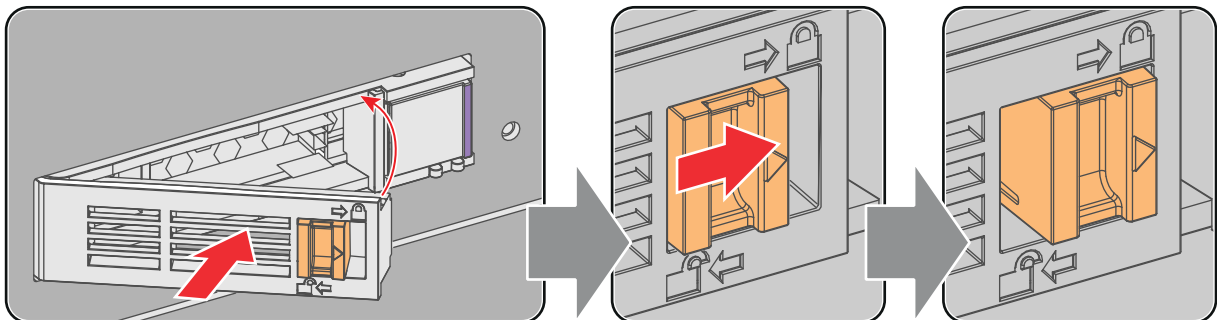

Image 3-9

5. Switch on the projector.



Even if you replace only one HDD (e.g. degraded mode), the projector must be switched off. The ICMP automatically starts with the RAID recovery process when the projector will be switched on. The red LED of the HDD which has to be rebuilt is blinking. This process takes about 200 GB per hour. Once the RAID is completed the red LED turns off.



**CAUTION:** It's strongly recommended to complete the RAID recovery process prior to starting a show. This to ensure that the content integrity is preserved and that the show is not interrupted.

## 3.6 ICMP-X reset

### ICMP-X reset possibilities

- The Reboot ICMP-X reset button in the GUI of the Web Communicator.
- The ICMP-X reset button in the GUI of the Web Commander.
- The ICMP-X hardware reset button located on the front panel of the ICMP-X (Not recommended, use only when all other reset possibilities are exhausted!)

### How to reset the ICMP-X?

1. click on the **Reboot ICMP-X** button in the GUI of the **Web Communicator** (recommended).

or

Click on the ICMP-X **reset** button in the GUI of the **Web Commander**.

As a result the projector is safely prepared for the ICMP reboot. All ongoing events on the ICMP-X (e.g. ingest) are requested to end. After a few seconds the ICMP-X is requested to restart. The READY LED on the front panel of the ICMP-X starts to blink orange.

Once the READY LED lit continuous green the ICMP-X is up and running.

2. Did the reset of the ICMP-X fail?

▶ **If yes**, perform a hardware reset as follows:

1. switch off the light source of the projector.
2. press the ICMP-X **hardware reset button** a few seconds (reference 3 [Image 3–10](#)).

**Warning:** Resetting the ICMP-X with the hardware reset button may cause damage to the content on the HDDs. A re-configuration of the whole system may be required!

As a result the projector is safely prepared for the ICMP-X reboot. All ongoing events on the ICMP-X (e.g. ingest) are stopped immediately and the ICMP-X restarts.

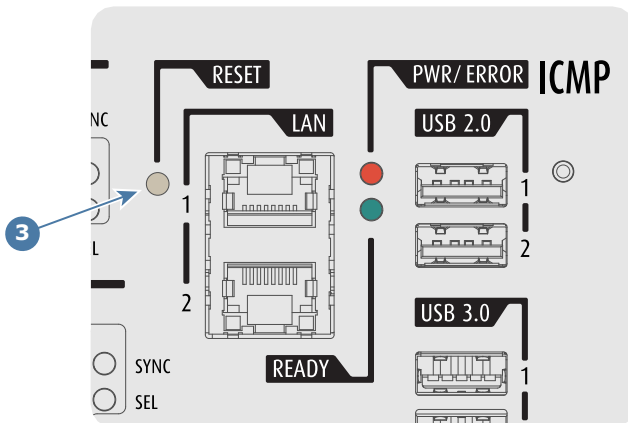

Image 3–10



**WARNING:** Resetting the ICMP-X with the hardware reset button may cause damage to the content on the HDDs. A re-configuration of the whole system may be required!

# Web Communicator – Graphical User Interface (GUI)

# 4

4.1	Graphical User Interface .....	46
4.2	Starting up .....	49
4.3	Installing SSL certificate to enable HTTPS protocol .....	50
4.4	Reset administrator password .....	54
4.5	Signing out from application .....	55
4.6	Modifying account settings (password) .....	56
4.7	Modifying preferences (language, theme, time format) .....	57
4.8	Search.....	58
4.9	Dashboard .....	59
4.10	User rights .....	60
4.11	Displaying open source license list.....	61
4.12	Application Menu tree .....	62

## 4.1 Graphical User Interface

### Overview

The user interface is organized around a *Menu* bar (reference 1), a *Status* bar (reference 2) and a working area (reference 3). Working area varies depending on the page in use. A *Side* bar (reference 4) always located at the left of the working area indicates in highlight the name of the current page.

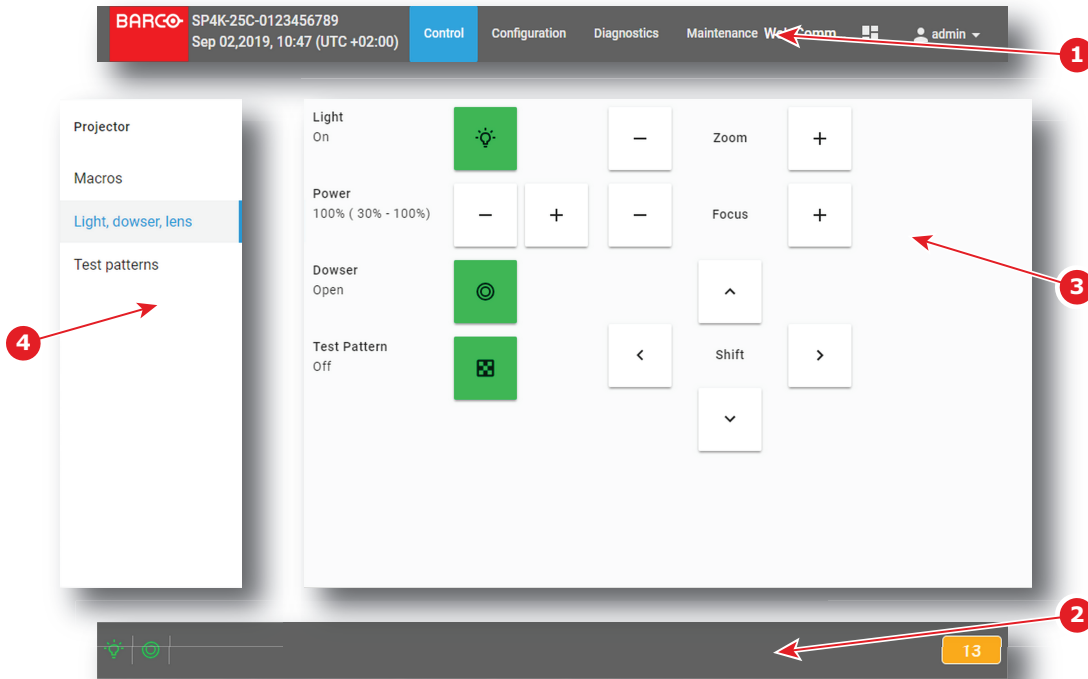

Image 4-1

- 1 Menu bar
- 2 Status bar
- 3 Working area
- 4 Side bar

### Menu bar

In the Web Communicator application, the *Menu* bar is always present regardless of the displayed page.

*Auditorium name*, *date* and *time* (reference 1) are displayed next to Barco logo. For more details concerning *Auditorium name*, please refer to chapter “[Network configuration](#)”, page 278. For more details concerning *date and time* adjustment, please refer to chapter “[Internal clock settings](#)”, page 185.



When the Auditorium name has been entered correctly, it is always available in the menu bar near the Barco logo, even when you are not logged in.

The general menu (reference 2) allows to reach all available pages of the application. An overview of the menu tree is available in section “[Application Menu tree](#)”, page 62.

*Web Commander* shortcut (reference 3) allows to run WebCommander, the web application provided by Barco to control ICMP (Integrated Cinema Media Processor). Only available when the projector is equipped with an ICMP. For more details please refer to ICMP user guide.

*Dashboard* shortcut (reference 4) allows to display a dashboard that provide general overview of all projectors located on the local network. For more details concerning dashboard panel, please refer to “[Dashboard](#)”, page 59.

*User icon* (reference 5) located at right is followed by the current user name. Click on this icon to open a short menu dedicated to account settings and logout. For more details concerning this menu, please refer to “[Modifying account settings \(password\)](#)”, page 56.

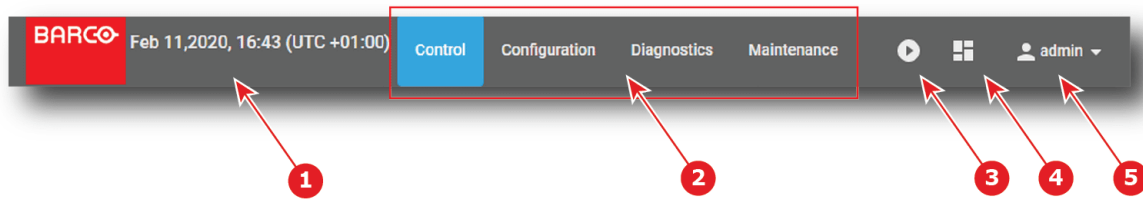

Image 4–2

- 1 Auditorium name
- 2 General menu
- 3 WebCommander shortcut (optional)
- 4 Dashboard shortcut
- 5 User icon

## Status bar

In the Web Communicator application, the *Status* bar is always present regardless of the displayed page.

Status icons (reference 1) provide information on the respective status of the dowser, the light source and the test pattern. Click on these icons to directly change these status, just like commands provided in *Control > Projector > Light, dowser, lens* menu. For more details concerning status icons, please refer to chapter “[Light, dowser, lens](#)”, page 71.

Multi-projector status icon (reference 2) lets you know if the projector is operating in multi-projector mode and if it is master (icon that represents a crown) or a slave (icon that represents a chain). Click on this icon to directly access to *Configuration > System access > Multi projectors* and modify multi projector settings.

Name of the last executed macro is displayed in the status bar (reference 3). Click on this macro name to directly reach *Configuration > Projector > Macros*, the panel that allows manage the macros of the projector. If the current user have limited rights (no access to configuration panels), click on this macro name allows to only reach *Control > Projector > Macros*, the panel that allows activate a macros of the projector. Note that nothing is displayed on the status bar if no macro has been run.

Notification icons (reference 4) located at the bottom right corner indicate the number of *error* notifications (in red) and the number of *warning* notifications (in yellow). Click on these icons allows to display the notification list (*Diagnostics > Monitoring > Notifications*). For more details concerning notifications, please refer to chapter “[Notifications](#)”, page 309.



Image 4–3

- 1 Status icons
- 2 Multi-projector status
- 3 Executed macro
- 4 Notification icons (errors and warnings)

## Side bar

The *Side* bar allows direct access to other pages located in the current sub section.

Name of the current page is highlighted (reference 1).

The name of the sub section where the active page is located is displayed on the top (reference 2).

You can hide the Side bar by left-clicking on the Side bar while holding the **<ESC>** key.

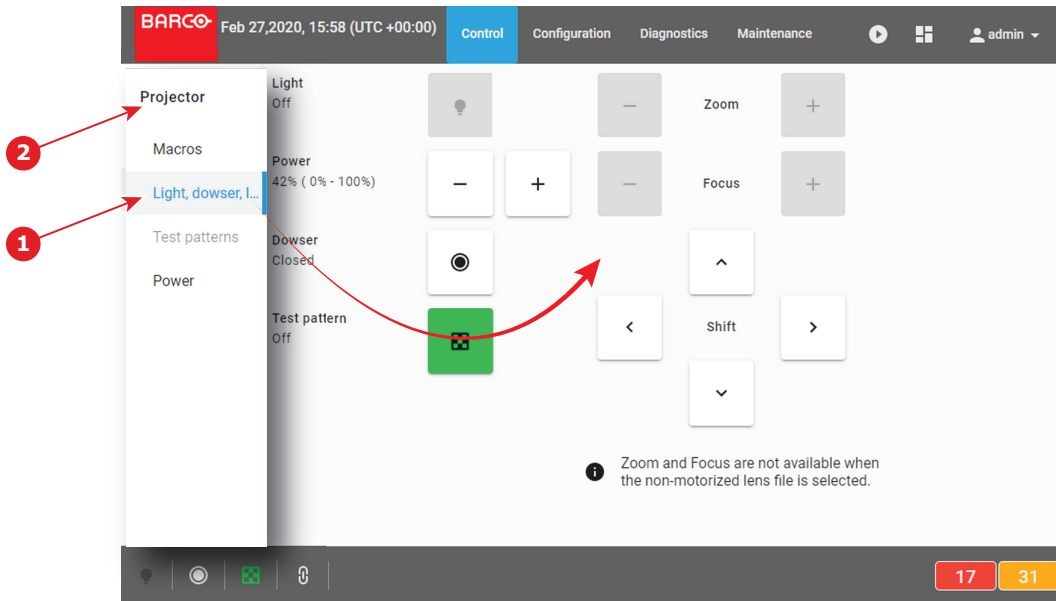

Image 4-4

- 1 Active menu
- 2 Name of the sub section where the menu is located

### Special GUI behavior on a limited screen area

When Web communicator is used in small window or when it runs on a device with a restricted display (e.g. a smart phone), a space-saving mechanism is automatically activated. The general menu is no longer displayed in the *Menu bar*. It is replaced by a collapsed menu icon (*hamburger icon*) located to the right side of the *Menu bar* (reference 1).

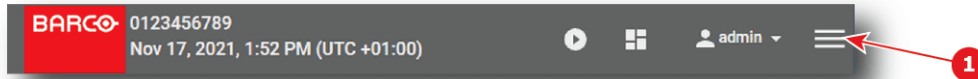

Image 4-5

Click on this icon (reference 1) to reveal an vertical version (also called Hamburger menu) of the general menu (reference 2) under the menu bar.

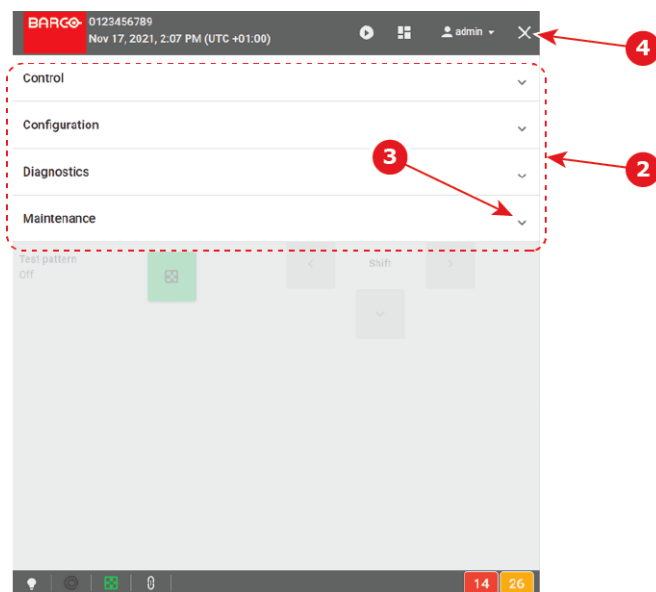

Image 4-6



Click on an element (reference 3) of the menu allows to display a sub menu. Continue to navigate in this way in the sub-levels to reach the targeted page.

Click on the *cross* (reference 4) to close the menu.

### Available list actions

Many pages of the application are based on a list of elements (reference 1) with slider (reference 2). A series of tools located at the top of the list (reference 3) makes it easy to sort or retrieve these items.

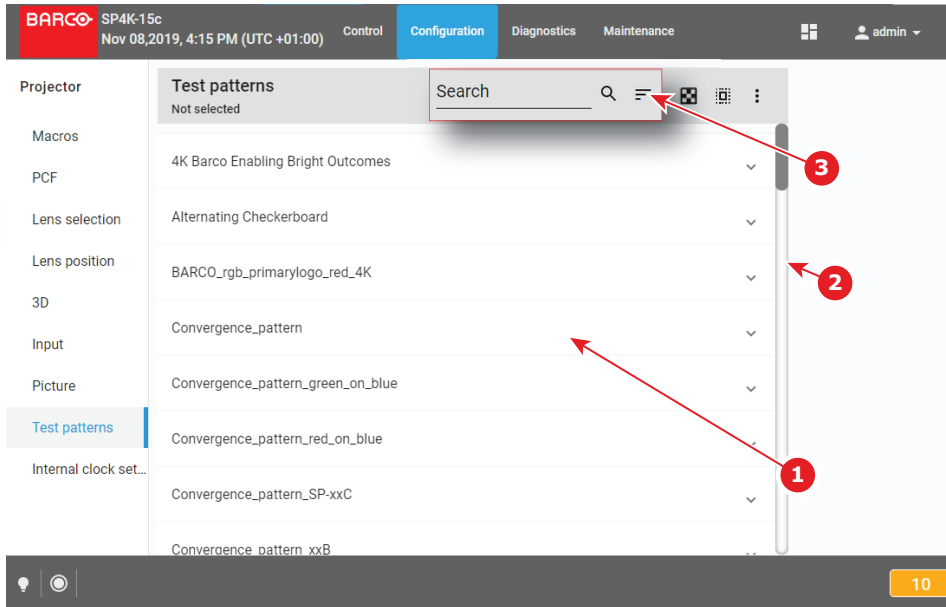



Image 4–7 e.g. list of lens in lens selection page.

Following actions could be used on list:

Action	Graphical Component	Description
Search		Allows to quickly retrieve one or several items in the list. See section “Search”, page 58 to obtain more details concerning the Search functionality.
Sort		Allows to sort the list according criteria selected (e.g. ascending or descending alphabetical order).

## 4.2 Starting up

### Prerequisites

The device has direct access to the projector LAN via Ethernet cable or Wifi, or it has open access via Internet.

### How to start up

1. Start a web Browser (Google Chrome, Mozilla Firefox ...).
2. Set the web application URL provided by the Cinema controller. The URL is composed of the HTTPS tag and the address of projector (e.g. https:// 150.158.252.210). The HTTPS (Hypertext Transfer Protocol Secure) communication protocol is used for security reasons. For more detail concerning HTTPS protocol and potential issues encountered with the SSL certificate, see “Installing SSL certificate to enable HTTPS protocol”, page 50. Refer to the projector’s installation manual for more information concerning the addressing of the cinema controller.

*Login* page is displayed once the connection with the server is established.

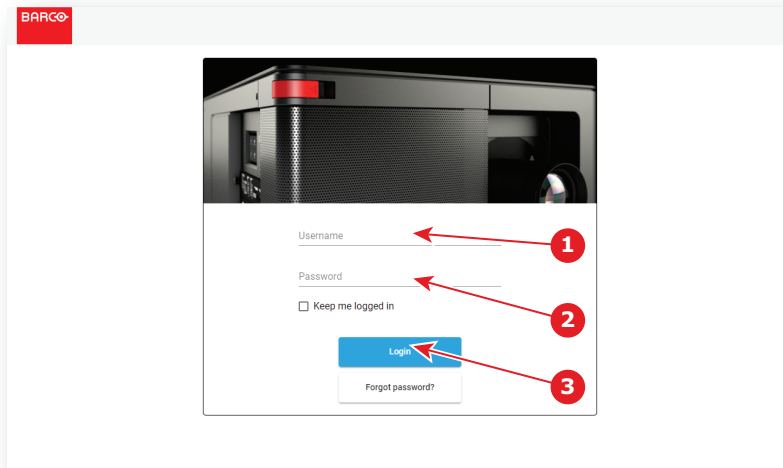



Image 4–8

3. Sign in using user name (reference 1) and password (reference 2) then push on Login button (reference 3).

 **Note:** Web Communicator is equipped with an auto logout mechanism that locks the application after a period of inactivity. Select the "Keep me logged in" checkbox to disable the auto-logout functionality.

Once logged, the landing page is displayed. By default this is the page dedicated to triggering the main projector controls (*Control > Projector > Light, dowsers, lens*). The landing page may vary depending on the user and the rights given to him. Depending on these rights, some parts of the application are accessible or blocked. For more details, please see the chapter dedicated to user rights in the next sections.

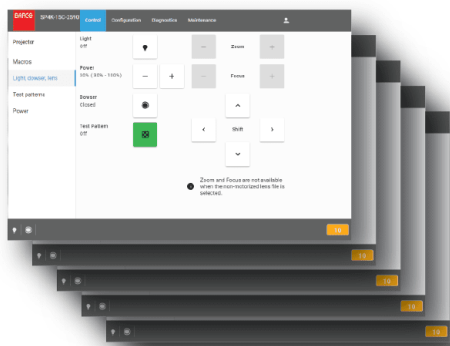

Image 4–9



The landing page can be accessed at any time by clicking on the Barco logo located on the Menu bar.

## 4.3 Installing SSL certificate to enable HTTPS protocol

### Overview

The HTTPS protocol (HyperText Transfer Protocol Secure) is the secure version of HTTP protocol which is the primary protocol used to send data between a web browser and a website. HTTPS is encrypted in order to increase security of data transfer (no information is passed in plain text). This type of security system uses public/private keys to encrypt communications between two parties and requires the use of a valid SSL (Secure Sockets Layer) certificate. The SSL certificate need to be downloaded from the projector web site and

manually installed on the web browser. Once the SSL certificate is installed the HTTPS protocol is enabled and the future connections will be established automatically as long as the certificate is valid.

### Connection error related to invalid or missing SSL certificate

One of the most common error encountered with the HTTPS protocol is “*your connection is not private*” error. The browser finds that there is a problem with the security protocol and it will automatically try to prevent you from reaching the site. This feature is built into web browsers to protect the user.

The way an error appears can vary a bit, depending on what browser you’re using.

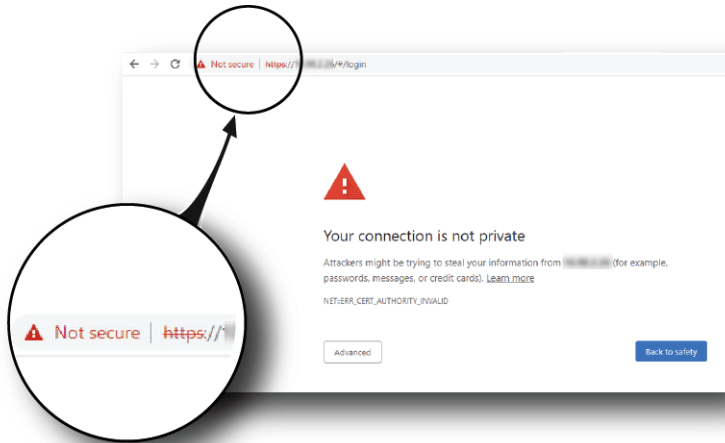

Image 4–10 e.g. Google Chrome

This issue will appear when the SSL certificate is not installed or is invalid. The HTTPS communication couldn't be established and it is necessary to consider installing a new certificate. Bypassing security and only using the HTTP protocol for your communication with the projector is not recommended.

Even if you do have an SSL certificate installed on your browser, there can be several reasons why the browser doesn't recognize the validity of this certificate. It is often a problem with the validity period. The certificate has a limited life period (2 years max) and it has expired. Or it is also possible that the settings on which the certificate is based have changed. For example, when the “Hostname” or “domain” values in the projector's network configuration are changed by the administrator, a new certificate is automatically calculated.

### How to download the SSL certificate in Windows using Chrome browser

1. Open a chrome browser and enter the portal url with *https* tag since its secured network (reference 1).

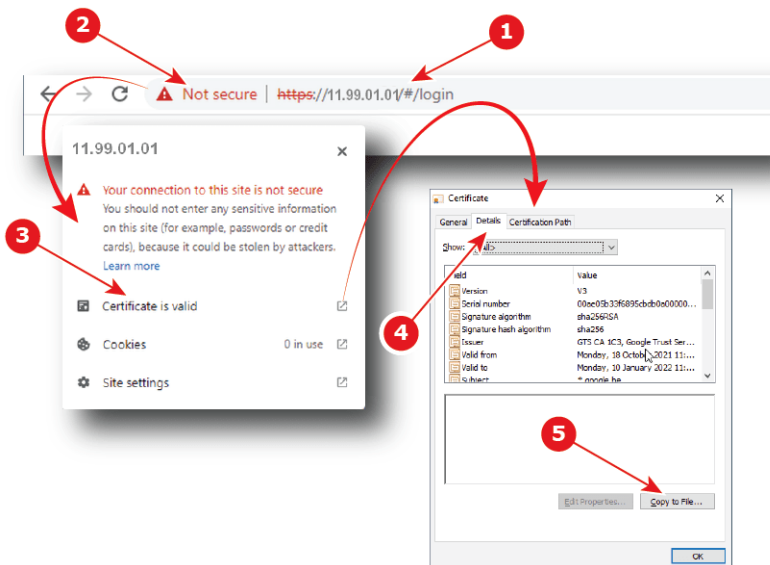

Image 4–11

2. Click on the *site information* button (reference 2) on the left of the url to display the menu.
3. Click on *View Certificate* (reference 3) to open up the *certificate* popup.
4. Click on the *Details* tab (reference 4).
5. Click to *Copy to File* (reference 5) to open up the *Certificate Export Wizard*.
6. Click to *Next* (reference 6), then select the export the “**DER encoded binary X.509 (.CER)**” file format (reference 7).

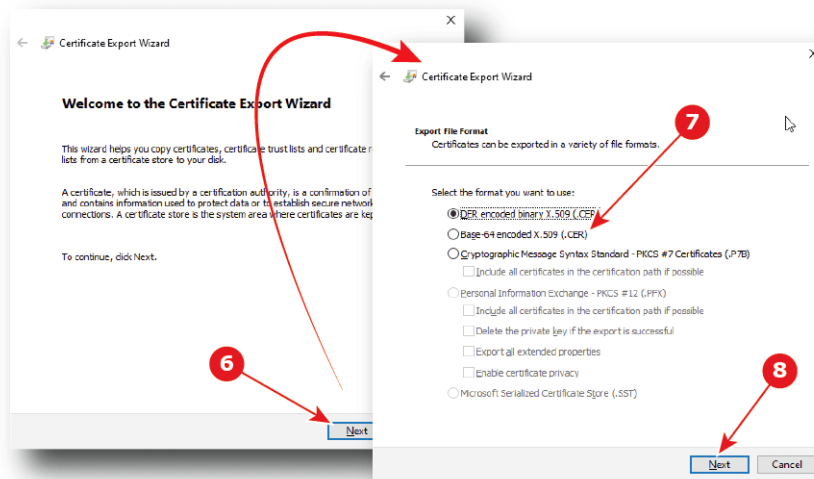

Image 4–12

7. Click to *Next* (reference 8), then specify the name and the location where you want to export the certificate (reference 9).

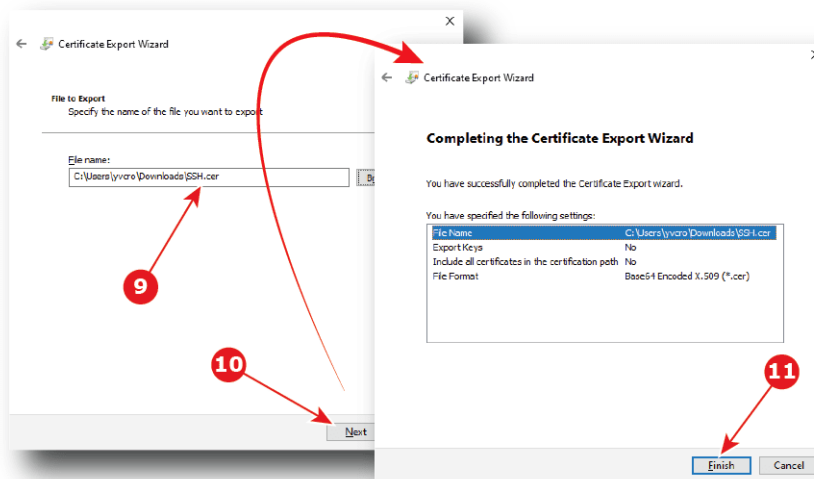

Image 4–13

8. Click to *Next* (reference 10), then click *Finish* (reference 11).  
The SSL file (certificate) is now available and need to be installed on your Browser.

## How to install the SSL certificate in your browser

1. Open a chrome browser and click *Customize and control* button (reference 1) in the upper right corner.

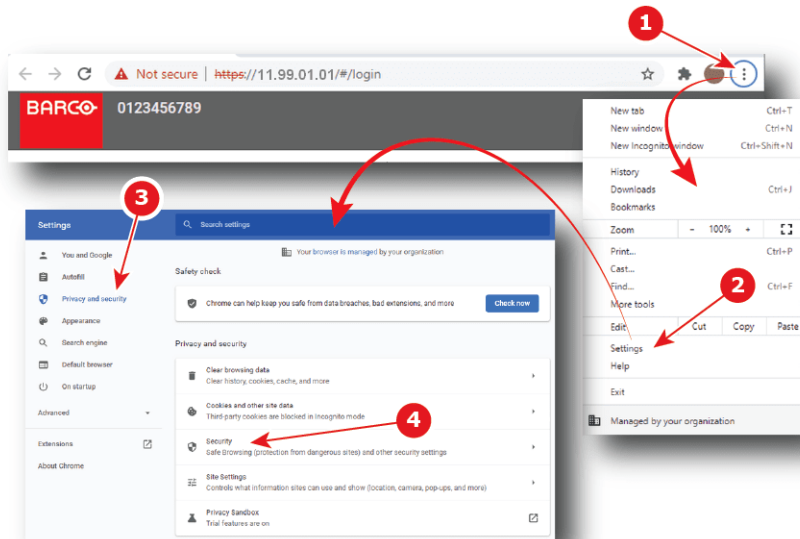

Image 4–14

2. Choose *settings* (reference 2) to open up the *settings* page.
3. Under *Privacy and security* section (Reference 3), click *Security* (reference 4) to display the menu dedicated to Safe Browsing (protection from dangerous sites) and other security settings
4. Scroll down (reference 5) and click to manage certificates (reference 6) to open up the *certificate* popup.

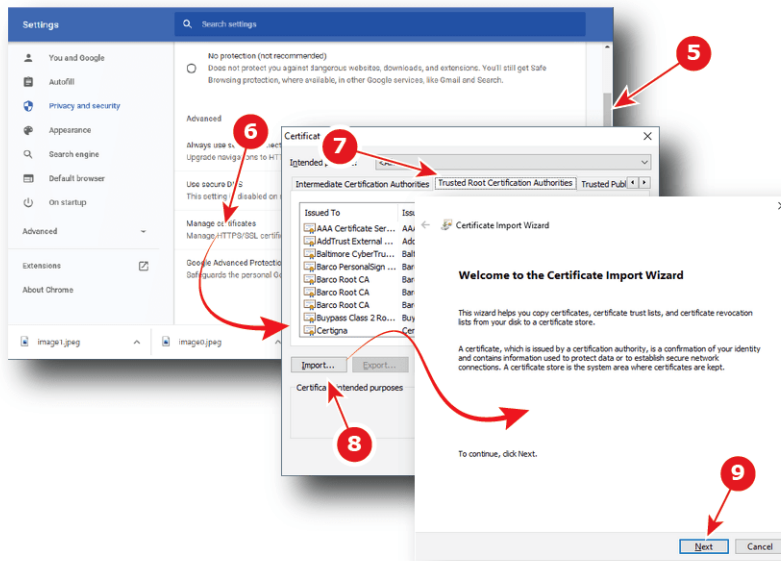

Image 4–15

5. Click on the *Trusted Root Certification Authorities* tab (reference 7).
6. Click to *Import* (reference 8) to open up the *Certificate Import Wizard*, then click *Next* (reference 9).
7. Specify the location and the name where the certificate is saved (reference 10) or use *Browse...* to retrieve the certificate (reference 11), then click *Next* (reference 12).

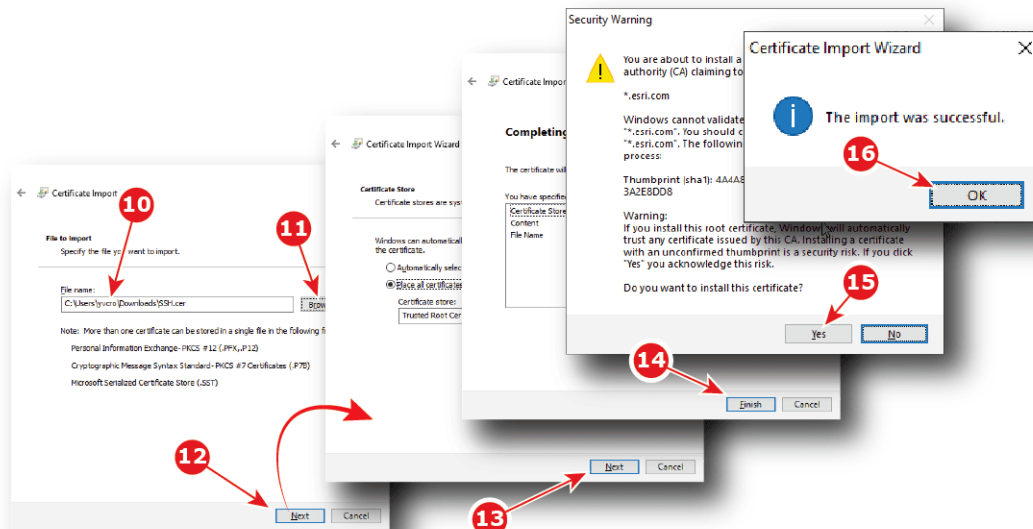

Image 4–16

8. Click *Next* (reference 13), then click *Finish* (reference 14) to close the *Certificate Import Wizard*.
9. After few seconds a *Security Warning* popup will appear. Click *Yes* (reference 15).
10. And finally click *Ok* in the *Certificate Import Wizard*.  
SSL certificate is successfully imported.

## 4.4 Reset administrator password

### About administrator password reset

In its factory configuration, the projector has a default password associated to the default admin user. If for any reason the administrator lost this password, there is no way to recover it.

The only way to resolve this situation is following the procedure to reset the administrator password. Procedure is based on principal of public and private keys pair. The administrator needs provide challenge code to the help desk that will send response code based on this code and the projector serial number.

### How to reset administrator password

1. Click on “**Forgot password?**” in the *login* page.  
A new page is displayed.

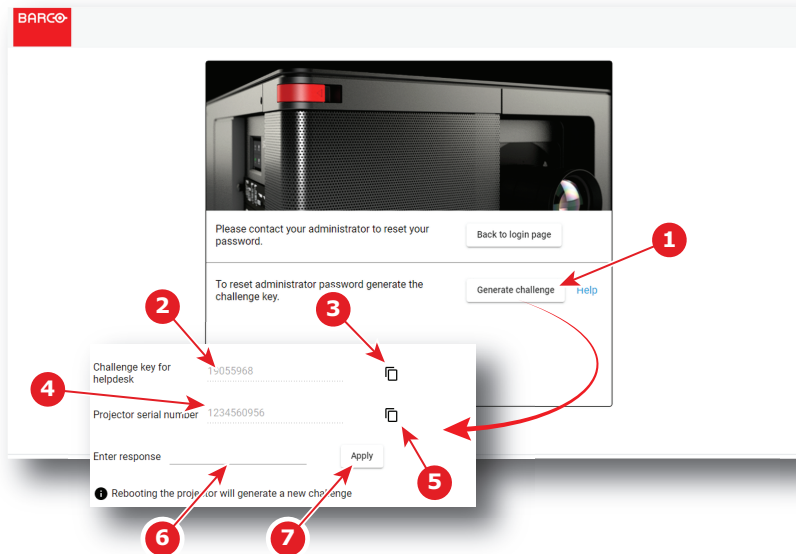



Image 4–17

2. Click on **generate challenge** button (reference 1).  
A challenge key number is generated (reference 2).
3. Click to *copy* icon (reference 3) to copy the challenge key number in the clipboard.  
 *Tip:* Saving this number in the clipboard will allow you to reuse it easily in the following steps.
4. Send a password reset request to the help desk. Provide the challenge key number (already in the clipboard since the previous step) and the projector serial number (reference 4) with your request. Avoid errors by using *copy* icon located near the projector number (reference 5) to copy projector serial number in the clipboard.  
The help desk will generate a response code. This code will be sent to you.
5. Enter the code in *Enter response* field (reference 6), then click on **Apply** (reference 7).  
If the code is correct, the default administrator user is available again. For more details concerning default user, please refer to “[User rights](#)”, page 60.



The current challenge key will become invalid if you entered the wrong response code three times or restarted the projector. If this occurred, this procedure will have to be repeated.

## 4.5 Signing out from application

### About logout

At any time you can choose to logout in order to change user.



The application is equipped with an auto logout mechanism that logs out the user after a period of inactivity. You can prevent this from happening by selecting the "Keep me logged in" checkbox when logging onto the Web Communicator (see “[Starting up](#)”, page 49).

### How to logout

1. Click on user icon (reference 1).  
Menu is displayed.

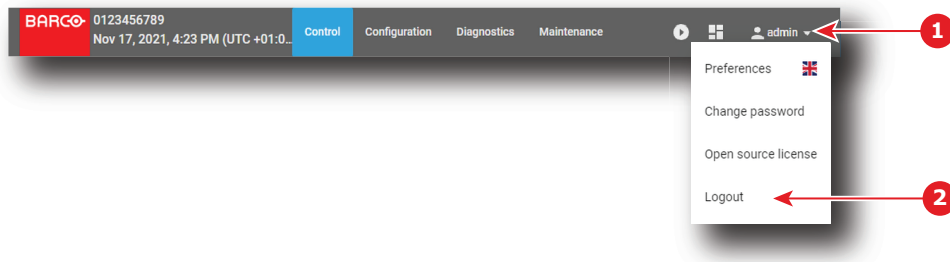

Image 4–18

2. Select *Logout* (reference 2).

User is disconnected and *login* page is displayed.

Credentials and password will be required to use the application again.

## 4.6 Modifying account settings (password)

### About account settings

Entire management of user (add or remove a user, change settings) is done in *Configuration > System access > Manage users* panel (see “[User management](#)”, page 285). However there is another way to change the password of the current user through the *change password* menu.

### How to modify the password

1. Click on the **user** icon (reference 1).

Menu is displayed.

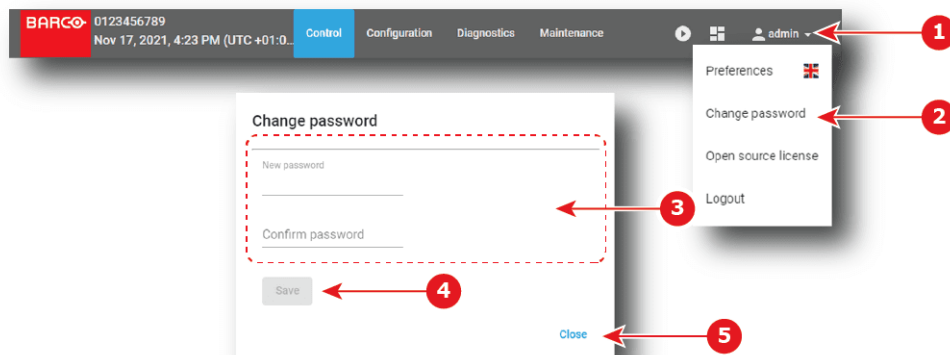

Image 4–19

2. Select *change password* (reference 2).

The *Change password* window is prompted.

3. Change the current password (reference 3): click in the *New password* field and enter the new password (use 8 or more characters), then click in *confirm password* field and re-enter the password to confirm. Both passwords must be identical.

4. Click **Save** (reference 4) to save the changes.

Password of the current user is changed.

5. Click on *close* (reference 5).

*Change password* page closes.



## 4.7 Modifying preferences (language, theme, time format)

### How to select another language

1. Click on user icon (reference 1).

Menu is displayed.

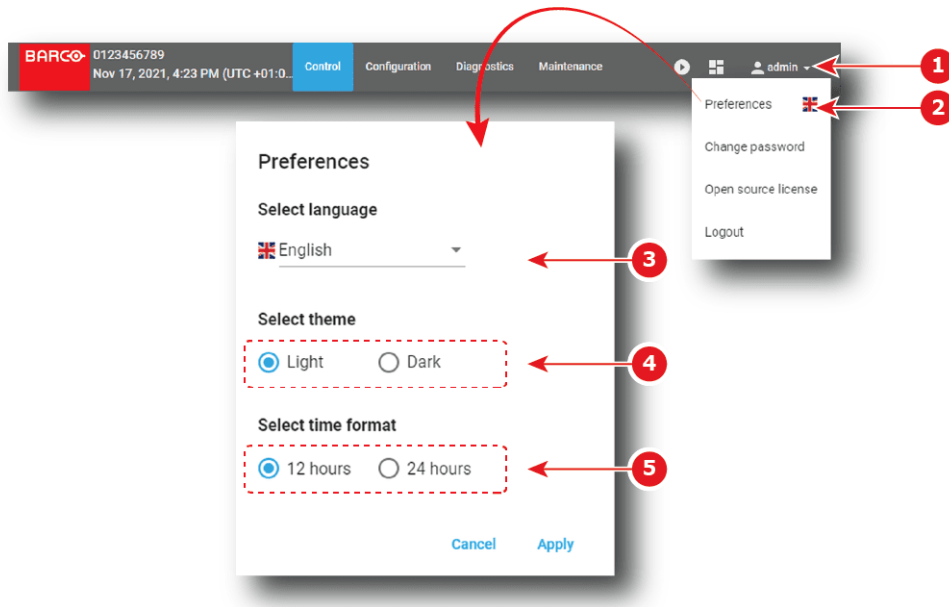

Image 4–20

2. Click *Preferences* (reference 2).  
The Preferences window is prompted.
3. Select a language in the *Select language* drop down list (reference 3).
4. Click on *Apply* to change language.  
GUI is immediately translated.

or

Click on *Cancel* to exit without apply change.

*Preferences* window closes.

### How to change theme

1. Click on user icon (reference 1, [Image 4–20](#)).  
Menu is displayed.
2. Click *Preferences* (reference 2, [Image 4–20](#)).  
The Preferences window is prompted.
3. Select the theme in the *Select theme* check list (reference 4, [Image 4–20](#)).
4. Click on *Apply* to change language.

*Preferences* window closes and selected theme is immediately applied.

or

Click on *Cancel* to exit without apply change.

*Preferences* window closes.

## How to change time format

1. Click on user icon (reference 1, [Image 4–20](#)).  
Menu is displayed.
  2. Click *Preferences* (reference 2, [Image 4–20](#)).  
The Preferences window is prompted.
  3. Select the time format in the *Select time format* check list (reference 5, [Image 4–20](#)).
  4. Click on *Apply* to change time format.  
*Preferences* window closes and selected time format is immediately applied.
- or
- Click on *Cancel* to exit without apply change.  
*Preferences* window closes.

## 4.8 Search

### How to use search

A search field is available in menus that display a list of items. Located above the list, search allows to quickly retrieve one or several items corresponding to an alphanumeric string:

1. Click in the field *Search*, then type in the name (or part of the name) you are looking for.  
The list is directly refreshed: items corresponding to the search are displayed.

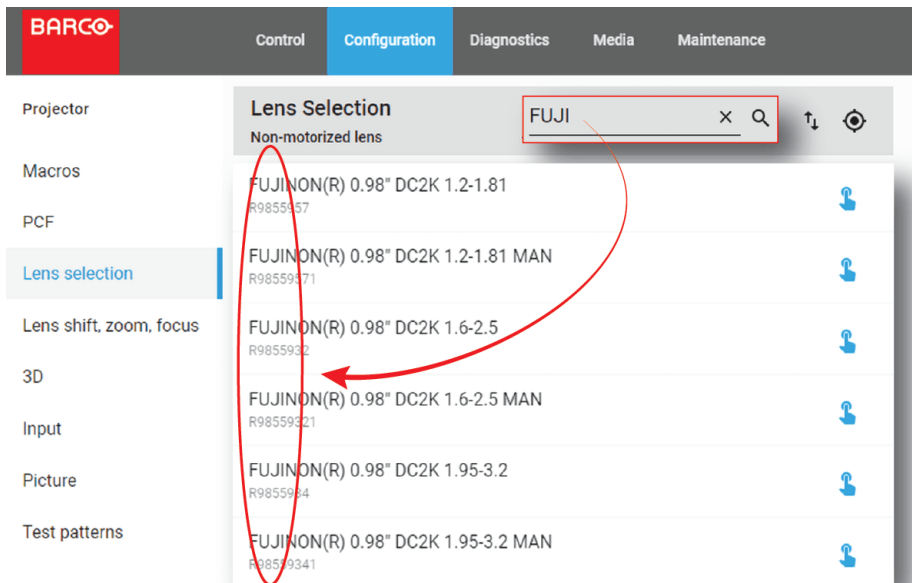

Image 4–21

The comment "No Record Found" appears if no result matching search criteria.

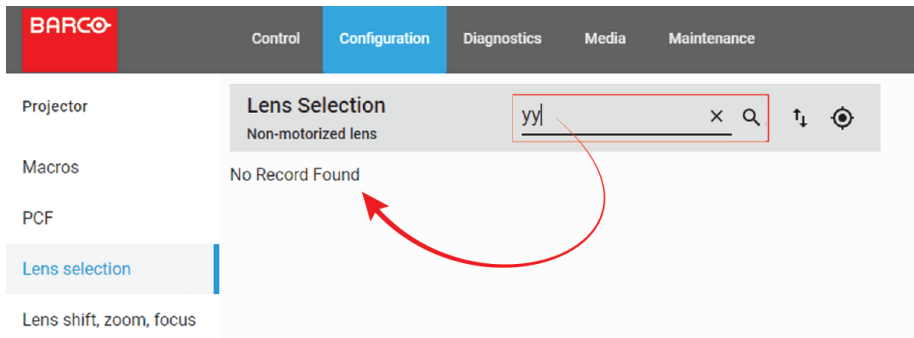

Image 4–22

- Click on the reset icon to reset the search.



Image 4–23

The entire list is displayed again. Nothing is filtered.

## 4.9 Dashboard

### About dashboard

At any time you can display dashboard to obtain status of Series 4 projectors connected on local network.

For each projector displayed on dashboard you have:

- the Auditorium name and IP address (reference 1).
- a slight overview of the projector status (reference 2):
  - *Light Source* status (on-off).
  - *Dowser* status (open-closed).
  - Name of last macro activated.
  - *Test pattern* status to know if test pattern is activated or not (on-off).
- a shortcut (reference 3) to launch a new Web Communicator instance dedicated to the targeted projector.

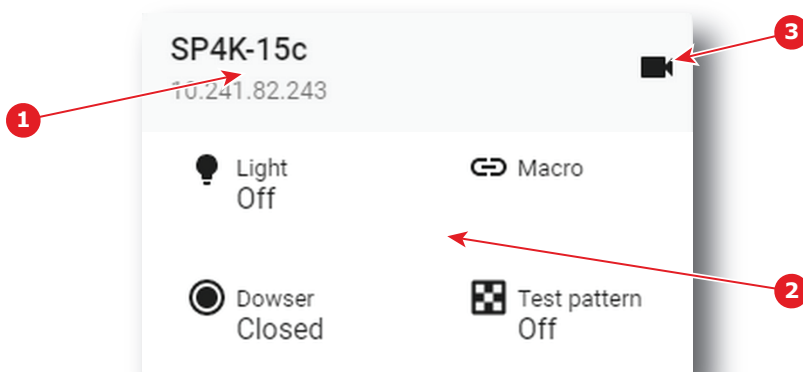

Image 4–24

### How to display/close dashboard

- In the menu bar, click on dashboard shortcut (reference 1).

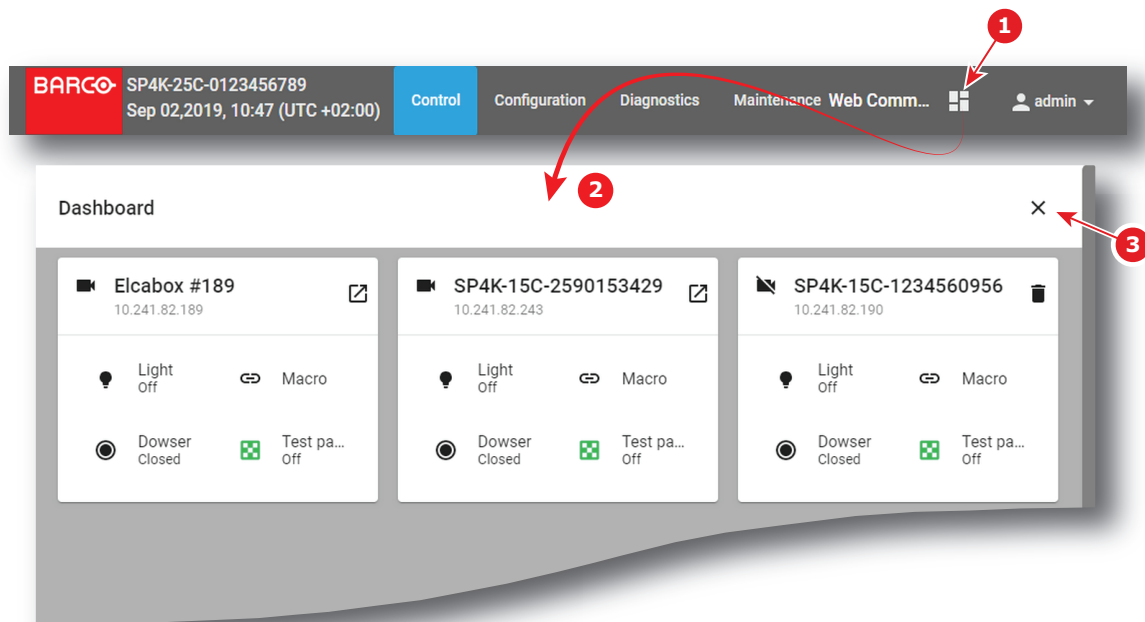

Image 4–25

Dashboard (reference 2) is displayed.

2. To quit dashboard, click the x (reference 3) button in the top right corner.  
Dashboard is closed.

## 4.10 User rights

### About users

Access to Web Communicator application is regulated by a principle of recognition of the user via a login. The user must be connected in order to perform an action (Control projector, modify settings,...). There are several levels of rights conferred on the user types.

## User groups and limitations

All users belong to one of the following user groups:

Groups	Description
Administrator	<ul style="list-style-type: none"> <li>Unlimited access to all application panels (projector control and settings, media server settings and automations).</li> <li>Has access to all diagnostics and maintenance panels.</li> <li>Can dynamically add/remove users and change the password for other users.</li> </ul>
Service Technician	<ul style="list-style-type: none"> <li>Service Tech level users can manage Show Managers level user</li> <li>Has access to the projector control and settings panels and to all media panels.</li> <li>Has access to diagnostics and maintenance panels except for software updates.</li> </ul>
Show Manager	<ul style="list-style-type: none"> <li>Can only access the projector control panels to start or stop a show</li> </ul>

Following rule is relevant:

- Users cannot delete or promote, demote themselves.

## Default users

When first accessing your projector, the following default users are pre-configured in the system.

Group	Login	Password
Administrator	admin	Admin1234
Service Tech	st	Service1234
Show Manager	show	Show1234



For security reasons, it is recommended to change the users and/or passwords as soon as possible.

## User management

All user management (adding or removing a user, change settings, etc) is done in *Configuration > System access > Manage users* panel (see ["User management"](#), page 285).

Changing the password of the current user is also possible through the account settings menu. For more details, please refer to section ["Modifying account settings \(password\)"](#), page 56.

# 4.11 Displaying open source license list

## About open source components

The software contains software components released under an Open Source License. Third party components used are listed here below.

## How to display the list of open source components

- Click on user icon (reference 1).  
Menu is displayed.

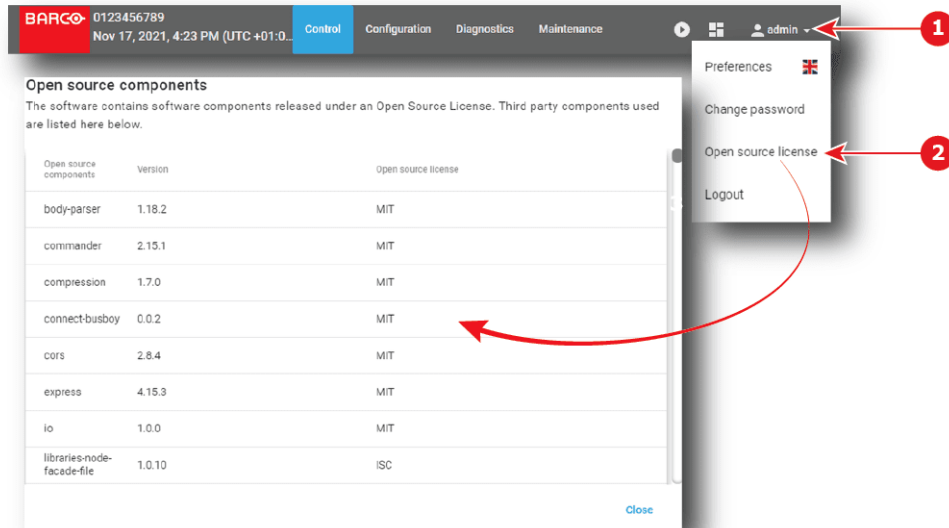

Image 4–26

2. Click *Open source license* (reference 2).

List of software components used in this application and currently under an open source license is displayed. Use the vertical scroll bar to scroll the list.

3. Click on *Close*.

*Open source components* page closes.

## 4.12 Application Menu tree

### Menu tree

The following diagram illustrates the application menu tree.

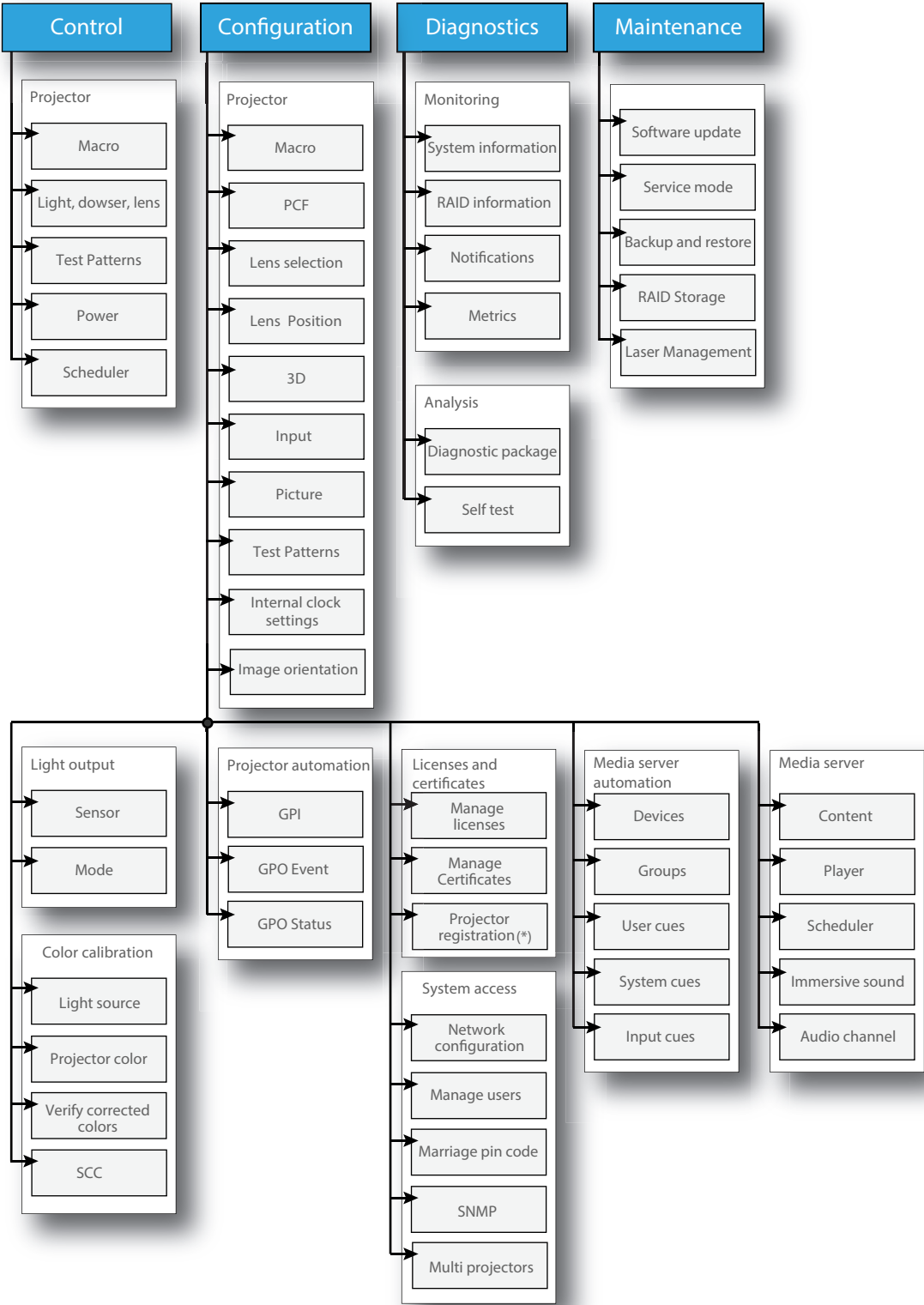

Image 4-27

(\*) Not applicable to all models/markets





# Projector configuration process overview

# 5

5.1	Prerequisites .....	66
5.2	Process overview .....	66

## About this chapter

After you have physically installed the projector, you can start with the configuration process. This chapter gives an overview of all the different stages in the configuration process which you have to follow to get your projector up and running. Each stage is briefly described and refers to more detailed step by step procedures in this manual.

**Use this process overview as a checklist to ensure that all stages have been followed in the configuration process of the projector.**

## 5.1 Prerequisites

### Overview

Prerequisites may vary depending on the projector model to install. The list of prerequisites provided here is indicative. For more information on each prerequisite, please consult the installation manual of the projector.

### List of prerequisites

The following prerequisites must be met before you start configuring the projector:

- The projector must be physically installed as written in the installation manual of this projector.
- Make sure the projector is connected to the power net via the mains or via a UPS.
- The appropriate lens must be installed in the projector lens holder, with or without lens adapter (depending on the projector type).
- Install optional peripherals, systems and devices (e.g. the exhaust adapter or the HDDs of the ICMP-X).

## 5.2 Process overview



This high level overview briefly describes all process stages that need to be done in a chronological order to configure the projector in a correct way using the Web Communicator. This overview does not include the physical installation process. For that refer to the installation manual of the projector.

### Projector configuration process

1. **Check if all prerequisites are fulfilled.** For more info see chapter “Prerequisites”, page 66.
2. **Switch on the projector.**
3. **Auditorium name and network configuration.** Fill in network configuration in order to interact properly with the projector via local network, and give a relevant auditorium name to easily identify it. Network configuration could be adjusted manually, or automatically via DHCP server. For more information concerning these settings see chapter “Network configuration”, page 278.
4. **Load a clone package** corresponding to the projector type and related to the chosen configuration (e.g. clone package is different if the projector is equipped with an ICMP-X or an ICP-D). See chapter “Backup and restore”, page 325.
5. **Activate and calibrate the lens** installed in the lens holder. Article number of the used lens must be identified in the lens list and activated, then an automatic calibration must be performed to detect reference points and middle position. See “Activating a lens”, page 115 and “Calibrating a lens”, page 116
6. **Switch on the light source.** See “Light Source on-off”, page 72.
7. **Open the Dowser.** See “Dowser open-close”, page 73.
8. **Display a test pattern on the screen.** Select a test pattern that allows you to perform *Flat* and *Scope* format settings. (e.g. *Framing\_uncorrected* testpattern). For more info concerning how to select test pattern, please see “Activating a test pattern using the control menu”, page 77.
9. **Testing the limits of the lens.** By using **Zoom**, **Shift** and **Focus** buttons, check if both flat and scope formats of pictures can fit into the screen with the current lens. For more info see procedures “Lens zoom”, page 74, “Lens shift”, page 74 and “Lens focus”, page 74.



*Tip:* High accuracy is not necessary during this test. The goal is to quickly test lens limits.



*Note:* Not being able to do one of the next steps means that you have to realize a back focus alignment directly on the lens, or the lens selected model is not suitable to this configuration.

10. **Creating the lens position files.** Now that the limits of the lens have been tested, we can save the lens positions for *Flat* and *Scope* formats. As described in the previous step, fit the image to the screen for the *Flat* format, then save the active configuration in file named Flat. Repeat the same operation with *Scope* format (save in file named Scope). See procedure “Creating a lens position file”, page 119.



*Tip:* It is recommended to create a slightly larger picture (2 or 3 pixels) to facilitate masking step that will come later.



*Note:* If needed, files dedicated to supplemental formats could also be created here (alternative contents with subtitles, ...).

- 11. Creating the screen files.** These files contain information about screen presentation configuration like resizing, letterboxing, masking and lens factor.  
Follow this procedure to create file related to *Flat* format, then repeat the same procedure to create the file related to *Scope* format. For more information, see [“Creating a screen file”, page 160](#).
- 12. Creating the input files (optional).** These files contain information about input configuration. This step is optional. By default input files are loaded with clone package. For more information concerning these settings see [“Creating an input file”, page 146](#).
- 13. Perform a white point calibration.** See [“White point calibration”, page 204](#).
- 14. Perform Color calibration** for all formats (see [“Creating a new MCGD file”, page 208](#)) then verify (see [“Verifying the colors after correction”, page 211](#)).
- 15. Perform Light sensor calibration** for all formats (Scope, Flat, 3D...). See [“Creating a new light sensor calibration file”, page 193](#).
- 16. Creating the macros.** Macro needs to be (automatically) executed before each show in order to set projector with correct parameter values related to the show. For more information see procedure [“Creating a new macro”, page 89](#).
- 17. Linking the macros to preset buttons.** Macro could be executed by clicking on preset button accessible on touch display located on *Input & Communication* side of the projector. See [“Linking a macro to preset button”, page 99](#).
- 18. Creating a profile** fit for each user acting with the projector. See [“Creating a user”, page 287](#).
- 19. Creating the marriage PIN codes.** It is recommended to create a PIN code for each user supposed to perform a marriage operation between Mediablock and projector. For more info see chapter [“Marriage pin code”, page 290](#).



# Control - Projector

# 6

6.1	Macros control.....	70
6.2	Light, dowser, lens .....	71
6.3	Test patterns control .....	76
6.4	Power .....	80
6.5	Scheduler .....	83

## About this menu

Control > Projector menu groups together all actions used to directly interact with the projector. It will be used to execute projector commands (e.g. zoom, open dowser, switch on the light source, ...), select and display patterns, or activate pre-programmed macros.



This menu is oriented to perform actions (e.g. execute preset or close dowser). Settings, modification of presets or loading/removing macros are not realized here but in configuration menus.



Depending if the connected projector is equipped with a media server or not, the menu items and the content of some items will be different.

## 6.1 Macros control

### 6.1.1 About macro control

#### Location & access

Menu: Control > Projector > Macros

Level: Administrator, Service technician, Show manager

#### Overview

All macros available in the projector are listed here. Use this page to activate a macro.

Use sort tool, at top of the list, to sort macros by ascending or descending alphabetical order, ascending or descending preset number or creation date.

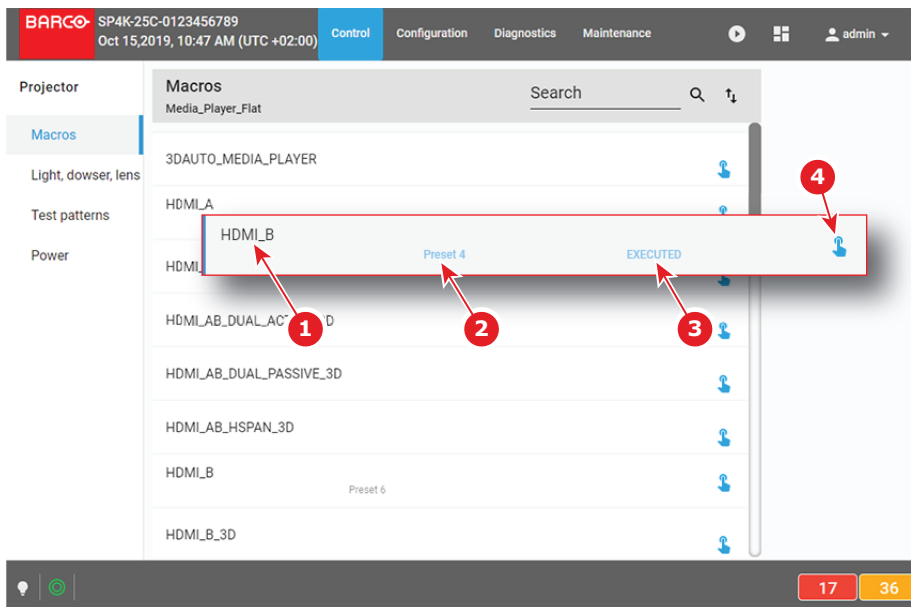

Image 6-1

Each macro displayed here has a *title* (reference 1). If a macro is associated with a preset button (projector keypad), the *preset number* (reference 2) is specified on the macro. For more details concerning link to preset buttons, please refer to chapter “[Linking a macro to preset button](#)”, page 99.

Click **Execute** (reference 4) allows to activate the macro. During its execution, the *status* of the macro (reference 3) turns to *BUSY*. When the macro is completed, the *status* of the macro (reference 3) turns to *EXECUTED*.

### 6.1.2 Activating a macro using the control menu

#### What is possible

A macro can be activated via one of the preset buttons (touch display located on *Input & Communication* side of the projector) or directly via a click on **Execute** button (see following procedure).

#### How to activate

1. While in *Control > Projector > Macro*, locate the macro you want to activate then click **Execute** (reference 1).



Image 6-2

Status of the macro (reference 2) turns to *BUSY* and content of the macro is executed (e.g. close dowser, activate PCF file ...).

2. After few moments execution is done.  
Status of the macro (reference 3) turns to *EXECUTED*.

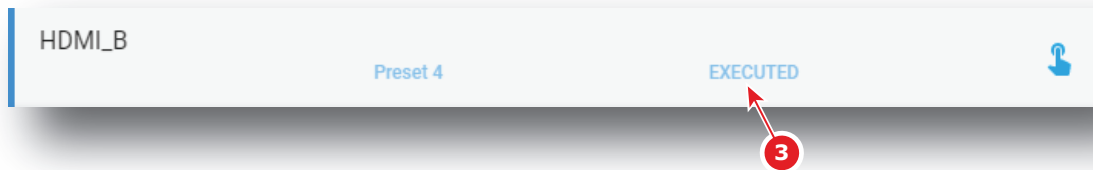

Image 6-3

### When an error occurs

If for some reason the macro does not run correctly, the status turns to *COMMANDFAILURE*. Click the info balloon (reference 4) to display Macro failure steps.

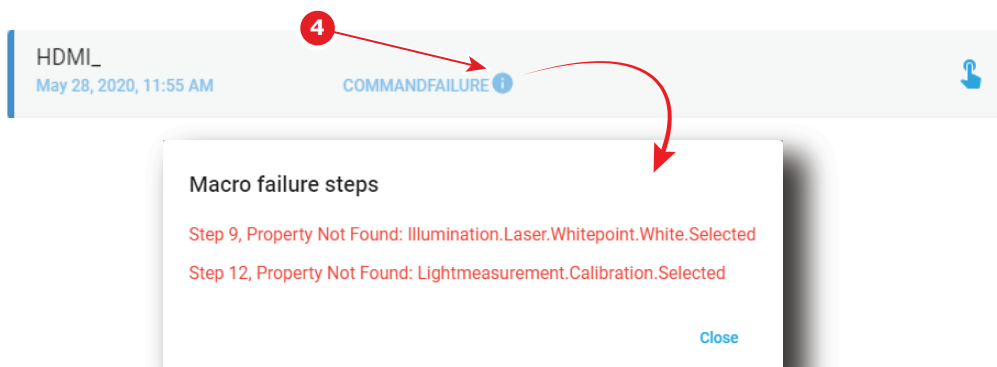

Image 6-4

## 6.2 Light, dowser, lens

### 6.2.1 About Light, dowser, lens menu

#### Location & access

Menu: Control > Projector > Light, dowser, lens

Level: Administrator, Service technician, Show manager

#### Overview

This menu is used to trigger some projector commands (dowser, light, test pattern...).

When a motorized lens is selected and correctly installed this menu also allows you to adjust lens settings (lens shift, focus and zoom). Otherwise Zoom, Shift and Focus buttons will be greyed out.

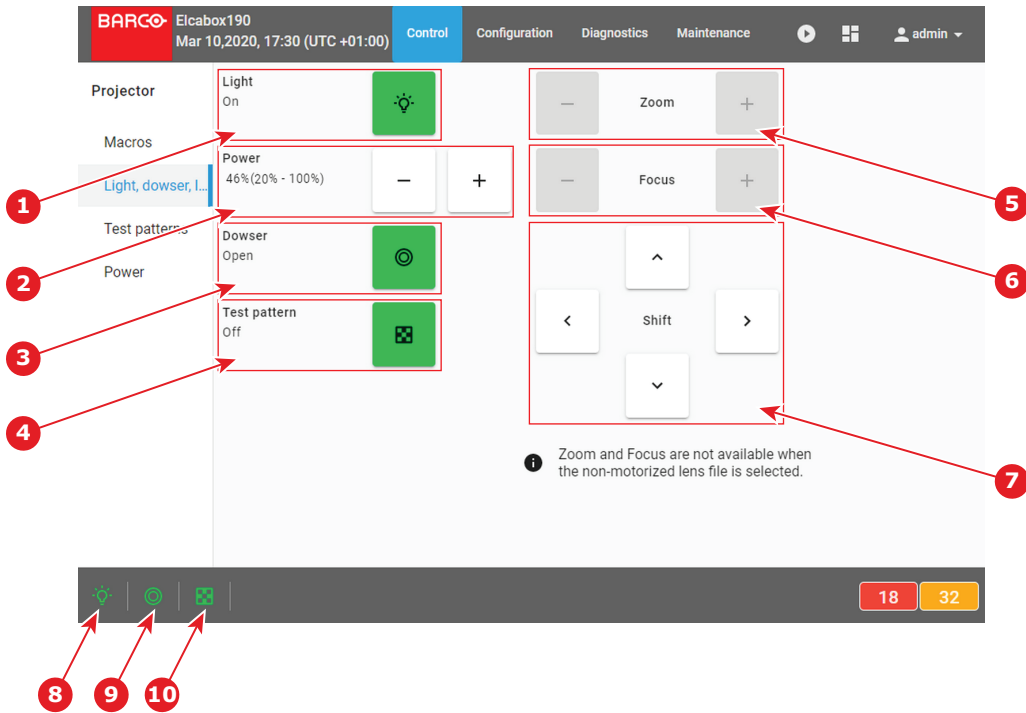

Image 6–5 Control > Projector > Light, Dowser, Lens

- |  |  |
|--|--|
| <ul style="list-style-type: none"> <li>1 Light Source on-off</li> <li>2 Light Source power increase-decrease</li> <li>3 Dowser open-close</li> <li>4 Test pattern on-off</li> <li>5 Lens zoom</li> </ul> | <ul style="list-style-type: none"> <li>6 Lens focus</li> <li>7 Lens shift</li> <li>8 Projector light source status</li> <li>9 Dowser status</li> <li>10 Test pattern status</li> </ul> |
|--|--|

## 6.2.2 Light Source on-off





### Location & access

Menu: Control > Projector > Light, dowser, lens

Level: Administrator, Service technician, Show manager

### How to switch on or switch off the projector light source

1. Click on the projector light source button to switch on or switch off the projector light source.

Button State	Projector light	Button color	Status icon
On	On	Green 	Light is On 
Off	Off	White 	Light is Off 

## 6.2.3 Light Source power increase-decrease

### Location & access

Menu: Control > Projector > Light, dowser, lens

Level: Administrator, Service technician, Show manager

### How to increase or decrease light source power

1. Power buttons allow to change intensity of the light source.

Use the **plus** button to increase the light source power.

or



Use the **minus** button to decrease the light source power.  
Intensity of the light source changes.

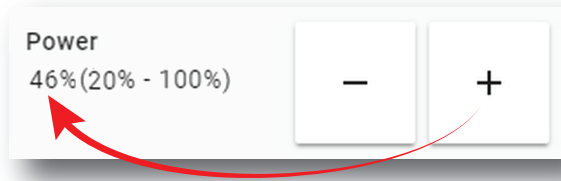

Image 6-6



The minimum light source power is limited to 20%.

## 6.2.4 Dowser open-close

### Location & access

Menu: Control > Projector > Light, dowser, lens





Level: Administrator, Service technician, Show manager



This dowser on the projector is not a mechanical dowser, but a software functionality.

### How to open or close the dowser

1. Click on the **Dowser** button to open or close the projector dowser.

Button State	Dowser	Button color	Status icon
On	Open	Green 	Dowser is open 
Off	Close	White 	Dowser is closed 

## 6.2.5 Test pattern on-off





### Location & access

Menu: Control > Projector > Light, dowser, lens

Level: Administrator, Service technician, Show manager

### How to activate or deactivate selected test pattern

1. Click on the **test pattern** button to activate test pattern.

Button State	Test pattern	Button color	Status icon
On	Activated (displayed on screen)	Blinks Green 	Icon blinks 
Off	Deactivated	Green 	Icon is lit continuously 

2. Click again on the **test pattern** button to activate the next test pattern in the preselected list. Repeat this action in order to switch to the next test patterns in the list.

3. Hold the **test pattern** button for more than 3 seconds to deactivate test pattern.

## 6.2.6 Lens zoom

### Location & access

Menu: Control > Projector > Light, dowser, lens

Level: Administrator, Service technician, Show manager

### How to zoom in or zoom out

1. Use the **plus** button to zoom in.

or

Use the **minus** button to zoom out.

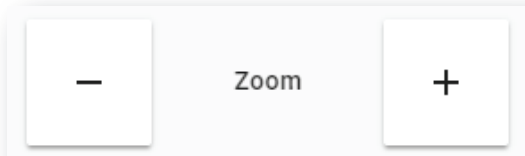

Image 6-7

or

Use keyboard arrows as described in [“Control key shortcut”, page 75](#).

## 6.2.7 Lens focus

### Location & access

Menu: Control > Projector > Light, dowser, lens

Level: Administrator, Service technician, Show manager

### How to adjust the lens focus

1. Use the **plus** button or **minus** button to adjust the focus of the lens.

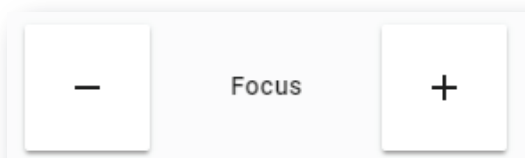

Image 6-8

or

Use keyboard arrows as described in [“Control key shortcut”, page 75](#).

## 6.2.8 Lens shift

### Location & access

Menu: Control > Projector > Light, dowser, lens

Level: Administrator, Service technician, Show manager

## How to shift the lens

1. Use the **Shift** buttons to correctly position (up/down/left/right) the projected image on the screen.

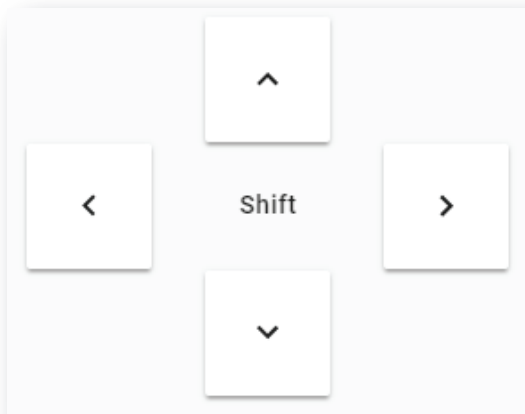

Image 6–9

or

Use keyboard arrows as described in [“Control key shortcut”, page 75](#).

## 6.2.9 Control key shortcut

### Overview

To facilitate lens settings, there are keyboard shortcuts that allow you to zoom, focus or position the lens while keeping your attention on the screen.

Key	Description
[TAB]	Tabulation key allows to toggle between Zoom, Focus and Shift settings.
[ESC]	ESC key allows to release control.
[ARROW Up] [ARROW Down] [ARROW Left] [ARROW Right]	For Zoom and Focus settings, [ARROW Up] and [ARROW Right] corresponding to “plus” button and [ARROW Down] and [ARROW Left] corresponding to “minus” button. For Shift settings, arrows directly positioning the image on the screen.

### How to control Lens with keyboard shortcut

1. While in *Control > Projector > Light, dower, lens*, click on the desired control settings (reference 4, 5 or 6).

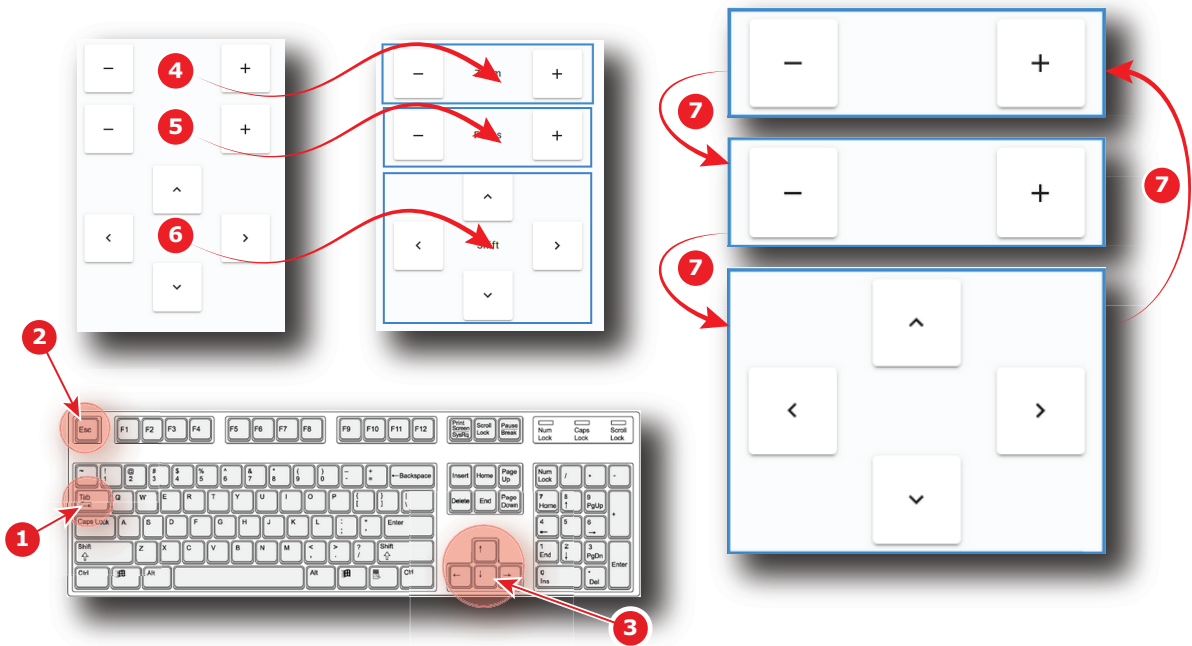

Image 6–10

One of the three available settings (Zoom, Focus or Shift) is selected. Selected control is highlighted with a blue rectangle.

2. Use **[TAB]** key (reference 1) to toggle between Zoom, Focus and Shift settings. Each time **[TAB]** is pressed, the selected control change (reference 5). The blue rectangle that highlight the area moves to the next one.
3. When the desired settings buttons are selected (Highlighted), use Arrows keys (reference 3) to adjust.
4. Click outside the selected control or hit **[ESC]** key (reference 2) to release control.

## 6.3 Test patterns control

### 6.3.1 About test patterns control

#### Location & access

Menu: Control > Projector > Test patterns

Level: Administrator, Service technician, Show manager

#### Overview

All test patterns available in the system are listed here. Use this page to activate or deactivate a test pattern.

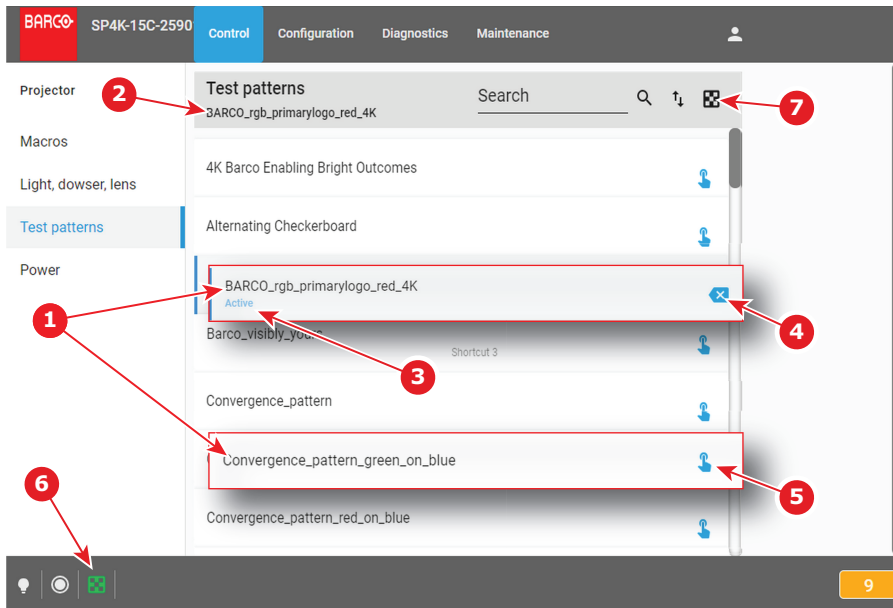

Image 6–11

Each test pattern displayed in this menu has a *Name* (reference 1).

When a test pattern is activated the following are available:

- the *status* of the test pattern (reference 3) turns to *Active*.
- name of the test pattern is noticed on top of the list (reference 2).
- **Deactivate** (reference 4) located to the right is available.
- Icon of test pattern (reference 6) is displayed (Blink Green) in status bar.

When no test pattern is activated the following are available:

- status of all test pattern are blank.
- *Not selected* is written on the top of the list (reference 2)
- **Activate** (reference 5) located to the right is available for all test pattern.

Click **Off TestPattern** (reference 7) located on the top right of the list allows to deactivate current test pattern without retrieve it in the list.



Test pattern is automatically displayed on the screen when it is activated.

## 6.3.2 Activating a test pattern using the control menu

### Location & access

Menu: Control > Projector > Test patterns

Level: Administrator, Service technician, Show manager

### How to activate a test pattern

1. While in *Control > Projector > Test Patterns*, scroll (reference 1) to the desired test pattern (or retrieve it with search function in the upper bar).

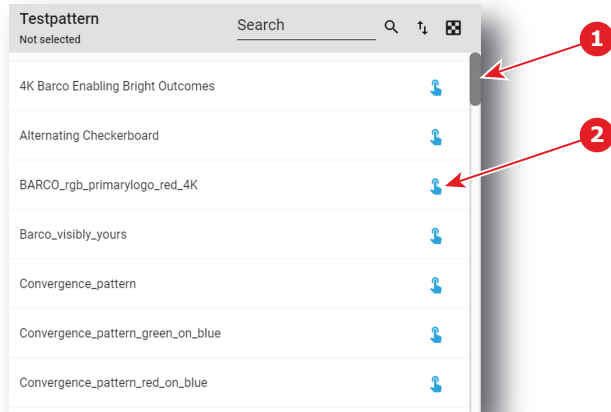

Image 6–12

2. Click **Activate** (reference 2).

The test pattern is now selected and automatically activated:

- Name of the test pattern is now displayed at the top of the list (reference 3).
- Status of the test pattern (reference 4) turns to *Active*.
- **Deactivate** (reference 5) is now available.
- Icon of test pattern (reference 6) is displayed (Blink Green) in status bar.

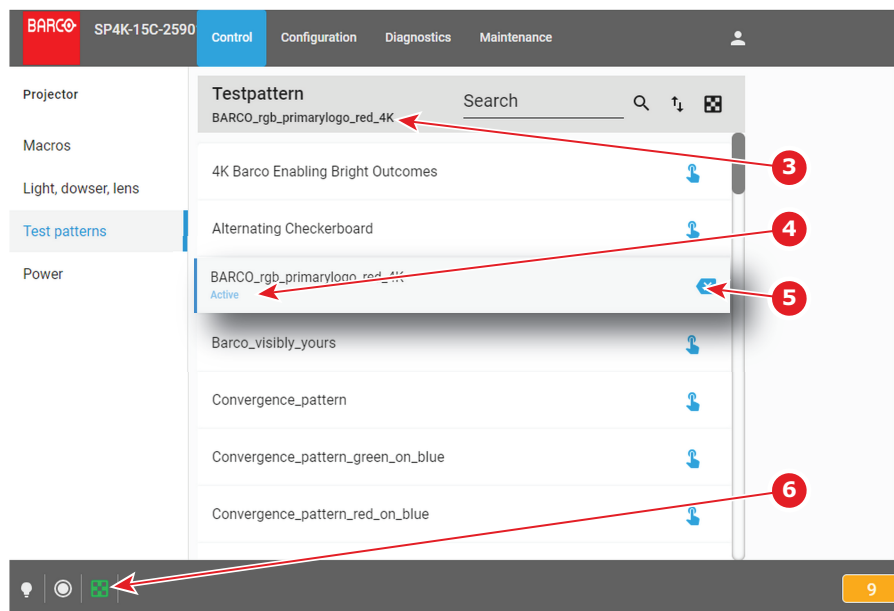

Image 6–13

### 6.3.3 Deactivating a test pattern using the control menu

#### Location & access

Menu: Control > Projector > Test patterns

Level: Administrator, Service technician, Show manager



Click on the *Off TestPattern* icon located on the top right of the list to deactivate the current test pattern without retrieve it in the list.

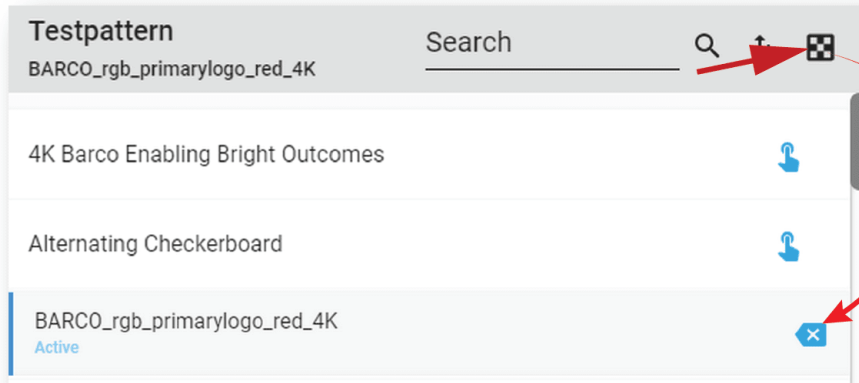

Image 6–14

## How to deactivate a test pattern

1. While in *Control > Projector > Test patterns*, locate the currently activated test pattern.

The status of the active test pattern is *Activate* (reference 2) and its name is noticed on top of the list (reference 1).

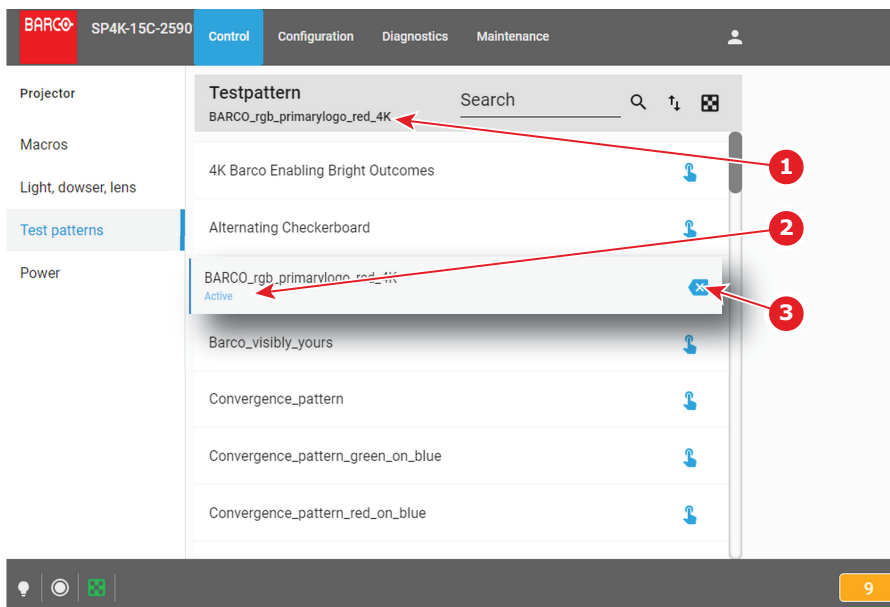

Image 6–15

2. Click on the **Deactivate** button (reference 3) located at the right.

Test pattern is deactivated:

- Name of the test pattern is removed from the top of the list and is replaced by *Not selected* (reference 4).
- Status of the test pattern turns to blank (reference 5).
- In the status bar, status icon dedicated to test pattern is switched off (reference 6).

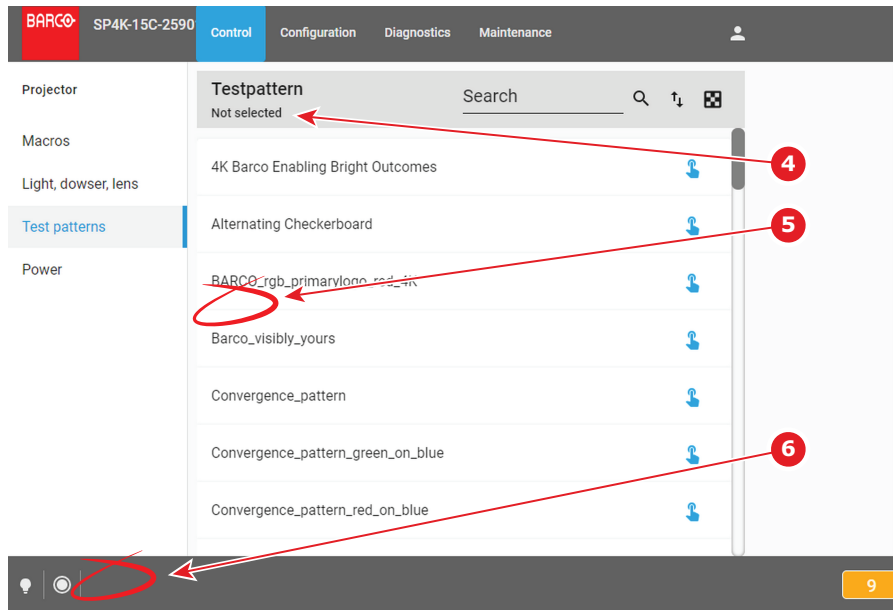

Image 6-16

## 6.4 Power

### 6.4.1 About Power menu

#### Location & access

Menu: Control > Projector > Power

Level: Administrator, Service technician, Show manager

#### Overview

This page groups together three commands related to power modes:

- **Switch to ECO mode** (reference 1). This will power down the media server and put in standby mode the projector electronic.
- **Reboot ICMP** (reference 2), only available if ICMP is present. This will reboot the media server only.
- **Full system reboot** (reference 3). This will reboot the projector and the media server.



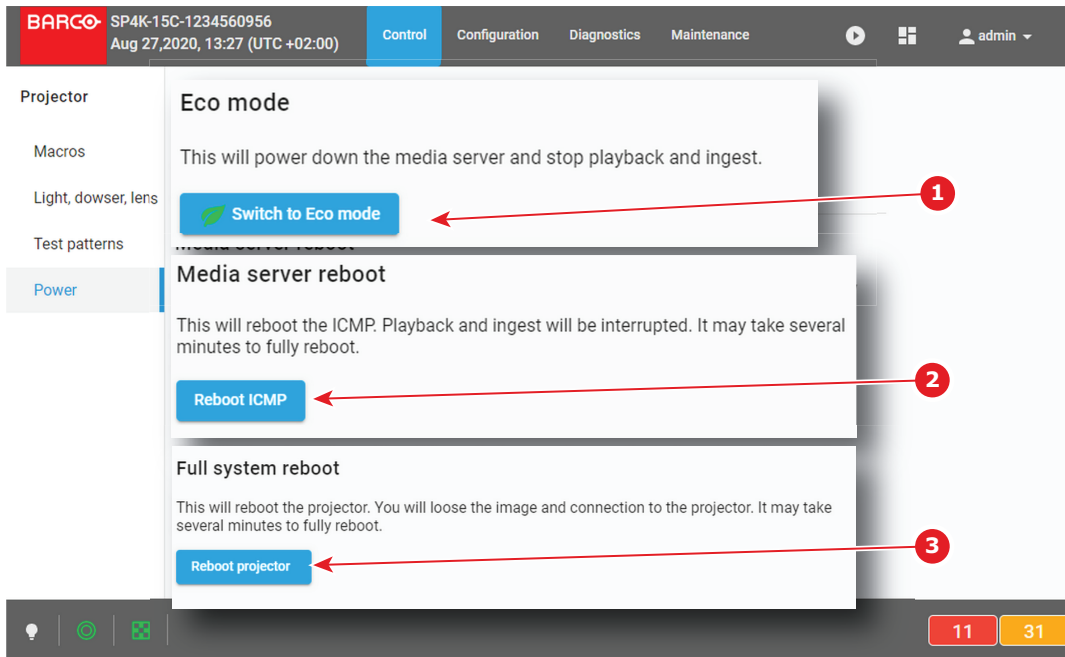

Image 6–17

## About Power modes

For more information concerning the power states of the projector, please refer to [“Explaining the power states”](#), page 28.

### 6.4.2 Switching to ECO mode

#### Location & access

Menu: Control > Projector > Power

Level: Administrator, Service technician, Show manager

#### How to switch

1. While in *Control > Projector > Power*, click on the **Switch to ECO mode** button (reference 1)

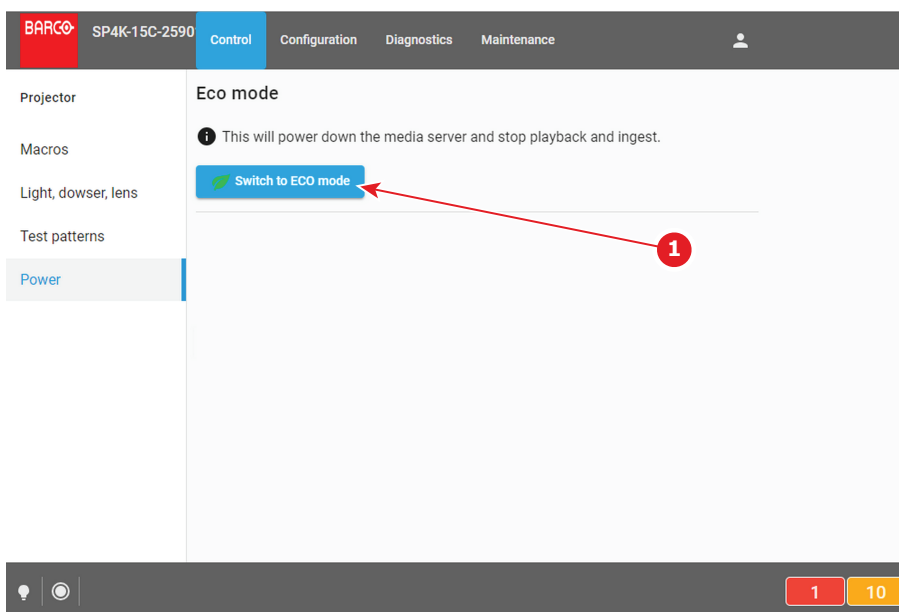

Image 6–18

Confirmation window is displayed to inform the user of consequences to switch to ECO mode. By example, this message inform if other users are currently connected or if playback is in progress.

2. Click on the **OK** to confirm and continue.

The projector switches to ECO mode. All ongoing activities are stopped (playback ...) and all electronics (including fans, pumps,...) will turn off, except for the wake up service. If you reload the page, you will find the wake-up page.

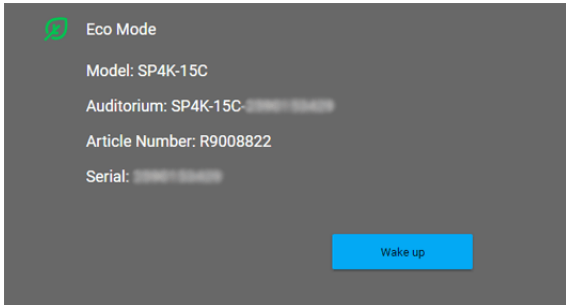

Image 6–19 Example of the Eco Mode page in Web Communicator

3. Press **Wake up** to turn the projector back to *Ready* state.

## 6.4.3 Rebooting the media server

### Location & access

Menu: Control > Projector > Power

Level: Administrator, Service technician, Show manager

### How to reboot the media server

1. While in *Control > Projector > Power*, click **Reboot ICMP**.

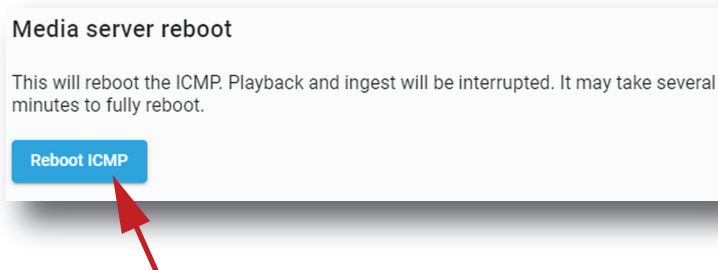

Image 6–20

2. Click **OK** to confirm.

The media server will reboot. This operation will take several minutes. Playback and ingest functions are not available during the reboot.

## 6.4.4 Full system reboot

### Location & access

Menu: Control > Projector > Power

Level: Administrator, Service technician, Show manager

### How to reboot the projector

1. While in *Control > Projector > Power*, click **Reboot projector** (reference 1).

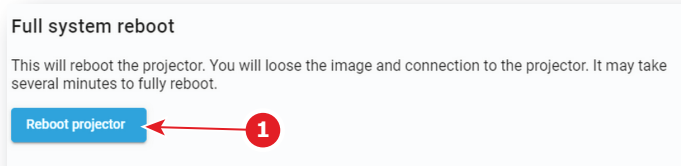

Image 6–21

2. Confirmation window is displayed.
3. Click **OK** to confirm.

The projector will reboot. This operation will take several minutes. All features (image, ingest ...) and connections are down during the reboot.

## 6.5 Scheduler

### 6.5.1 About Scheduler

#### Location & access

Menu: Control > Projector > Scheduler

Level: Administrator, Service technician, Show manager

#### Overview

This menu is used to schedule the automatic switch on (Wake-up) and shutdown (switch to ECO mode) of the projector.

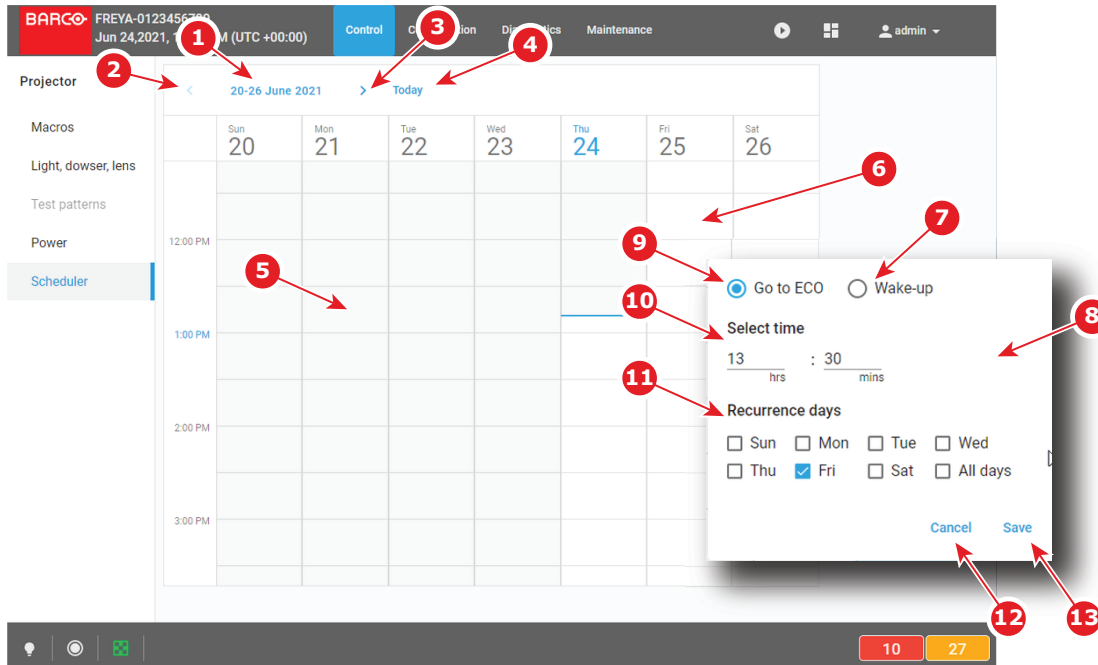

Image 6–22

The scheduler allows an overview on one entire week. The date of the week is displayed on the top (reference 1).

One column represents a day of the week. Slots in the day are represented by rectangles (one slot each half hour).

The vertical axis is graduated in hours. Use the scroll bar located on the right side to display the rest of the day if needed.

A blue line indicates the current time. The area located temporally before this line (reference 5) is grayed. No further action is possible on time slots located in the grayed area (in the past). Only slots located after this line, in clear area (reference 6) are accessible.

Following actions are available in this menu:

- **Left Arrow** (reference 2) moves the week view for one week to the left (the previous week).
- **Right Arrow** (reference 3) moves the week view for one week to the right (the next week).
- **Today** (reference 4) allows to display a view of the scheduler centralized on the current day.
- Click on a slot located after the current time displays a popup (reference 8) that allow to set an automatic switch on (reference 7) or an automatic shutdown (reference 9) of the projector. The time of triggering of an action can be modified (reference 10) and automatically repeated in the week by checking one or several days of the week in the “*recurrent days*” section (reference 11).
- Remove a shutdown (*Go to ECO*) or a switch on (*Wake-up*) already present by clicking on it.

Once automatic switch on (reference 14) and shutdown (reference 15) of the projector are fixed, the areas located between a *Go to ECO* and the next *Wake-up* are turn in green hatched area (reference 16). The projector will be in ECO mode in this period without possibility to play.

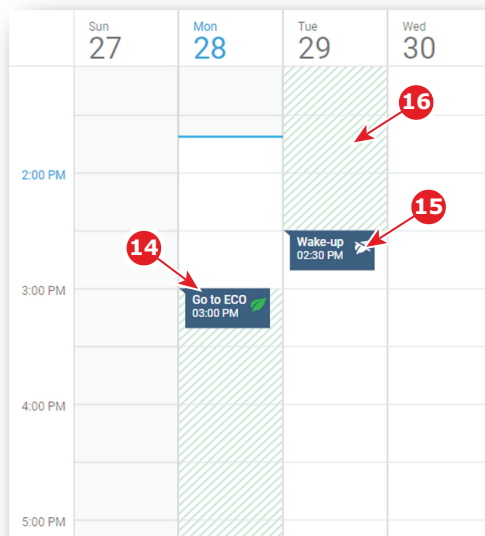



Image 6–23

## 6.5.2 Scheduling of automatic switches on or shutdowns of the projector..

### How to add an automatic switch on or an automatic shutdown of the projector in the scheduler

1. While in *Control > Projector > Scheduler*, locate and click the empty slot where you want add an action in the scheduler.

 **Note:** Only the slots located after the current time (clear area) are reachable. Other slots are greyed.

A dialog with parameters related to projector switch on or shutdown action is prompted.

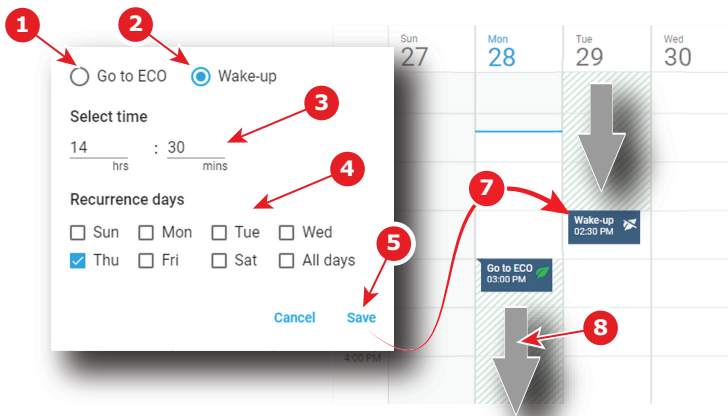

Image 6–24

2. Select the action type:
  - switch on the projector (Wake-up) (reference 2). The projector will automatically start powering up to Ready-mode at the selected time.
  - shutdown the projector (Go to ECO) (reference 1). The projector will automatically switch in ECO mode at the selected time.
3. If necessary you can modify or refine the trigger time of the action.
4. Check one or several days of the week in the “*recurrent days*” section (reference 4) to repeat this action in the week (recurrence).
5. Click Save (reference 5).  
The action is added in the scheduler (reference 7) and the areas located between the *Go to ECO* and the *Wake-up* is in green hatched (reference 8).

### How to remove an automatic switch on or an automatic shutdown of the projector from the scheduler.

1. While in *Control > Projector > Scheduler*, locate the automatic action you want to remove then click on it (reference 1).  
A contextual menu appears (reference 2).

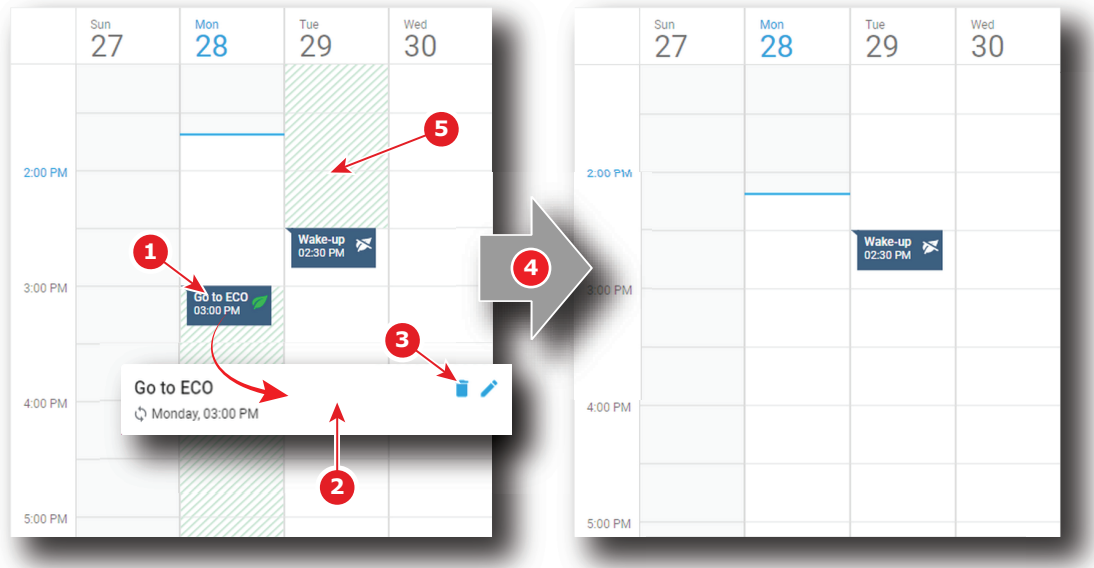

Image 6–25

2. Click **Delete** (trash icon) in the menu (reference 3).  
A confirmation message appears.
3. Click **OK**.  
The action is removed from the scheduler (reference 4). The area in green hatched (reference 5) is recalculated or removed depending on the position or the type of action removed.

# Configuration - Projector

# 7

7.1	Macros configuration .....	88
7.2	PCF.....	105
7.3	Lens selection .....	114
7.4	Lens position .....	118
7.5	3D .....	127
7.6	Input.....	145
7.7	Picture .....	159
7.8	Test patterns .....	176
7.9	Internal clock settings .....	185
7.10	Image Orientation .....	188

## About this menu

The Configuration > Projector menu is used to configure the projector.

## 7.1 Macros configuration

### 7.1.1 About macro configuration

#### Location & access

Menu: Configuration > Projector > Macros

Level: Administrator, Service technician

#### Overview

This panel allows to manage macros of the projector.

Use sort tool, at top of the list, to sorted macros by ascending or descending alphabetical order, ascending or descending preset number or creation date.

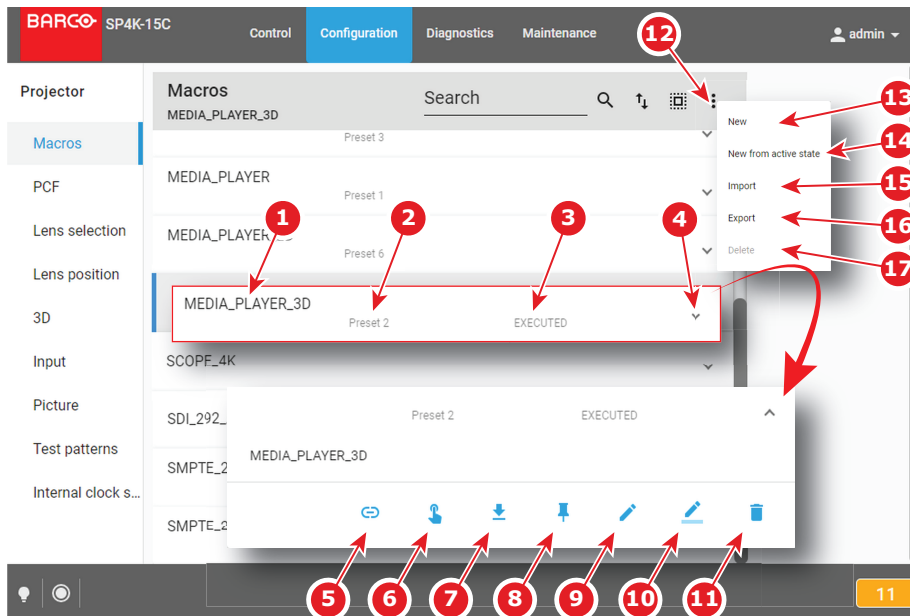

Image 7-1

Each macro displayed here has a *title* (reference 1). If a macro is associated with a preset button (projector keypad), the *preset number* (reference 2) is specified on the macro. For more details concerning link to preset buttons, please refer to chapter “[Linking a macro to preset button](#)”, page 99.

Click on a macro (reference 4) in this list allows to show it in its expanded form and displays a contextual menu.

Following actions are available in this menu:

- **Save as cue** (reference 5) allows to create a cue on the ICMP.
- **Execute** (reference 6) allows to activate the macro. During its execution, the *status* of the macro (reference 3) turns to *BUSY*. When the macro is completed, the *status* of the macro (reference 3) turns to *EXECUTED*.
- **Export** (reference 7) creates a downloadable backup package.
- **Link/Unlink to preset** (reference 8) allows to link or unlink the macro with preset button of the projector keypad.
- **Edit** (reference 9) allows to modify the macro.
- **Rename** (reference 10) allows to modify the name of the macro.
- **Delete** (reference 11) allows to remove the macro from the list.

Clicking on menu (reference 12) displays the macro general menu.

Following actions are available in this menu:

- **New** (reference 13) allows to create a new empty macro.



- **New from active state** (reference 14) allows to create a new macro pre-filled with commands corresponding to current projector state.
- **Import** (reference 15) allows to import macro.
- **Export** (reference 16) creates a downloadable backup package that contains all macro files selected in the list.
- **Delete** (reference 17) allows to remove selected macro files from the list..

## 7.1.2 Creating a new macro

### How to create a new macro

1. While in Configuration > Projector > Macros, click on the **menu icon** (reference 1) located on the top right of the list, then select **New** (reference 2) in the menu.

The macro editor opens with a new, empty *untitled* macro (reference 3).

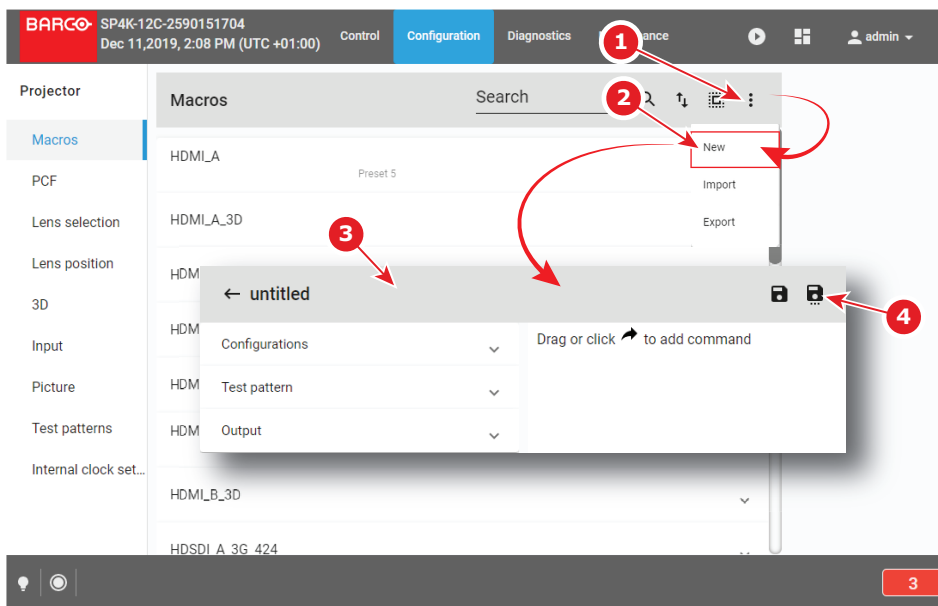

Image 7–2

2. Add commands in the macro. For more information about the *Macro editor*, see “[Macro editor](#)”, page 90.
3. Click the **Save** or **Save As** (reference 4) icon to prompt the *Save As* dialog. Enter a name then click **Save** to save modifications.

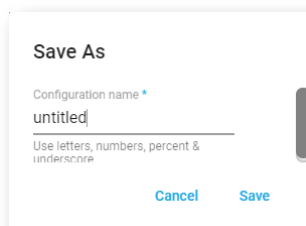



Image 7–3

 **Note:** List of Macros already available in the projector is displayed in this window. Directly click on this list allows you to reuse all or part of an already existing macro name.

4. Enter a name and confirm with **Save**.
5. Click the **Return** icon to return to the macros menu.  
The newly created macro is added to the list of macro files.

### 7.1.3 Creating a new macro from active state

#### How to create a new macro from current projector state

1. Check if projector settings are in accordance to the desired configuration.
2. While in Configuration > Projector > Macros, click on the **menu icon** located on the top right of the list to select **New macro from active state**.

The macro editor opens with a pre-filled macro (commands already present correspond to the current state of the projector).

3. Finish the macro creation and save it as described in procedure “Creating a new macro”, page 89.

### 7.1.4 Macro editor

#### About this chapter

This chapter contains all the necessary information to use macro editor, the Web Communicator page used to create or modify macros.

#### 7.1.4.1 General

##### About Macro editor

Use the *Macro editor* to create or modify macros. This page is not directly accessible via a general menu. Click **Edit** to modify a macro in a contextual menu (reference 1) or click **New** in the macro general menu to create a new macro (reference 2). For more information, please consult the sections dedicated to these operations in chapter “Macros configuration”, page 88.

The *Macro editor* consists of a commands set distributed in several tabs (reference 3) and an ordered list of commands (reference 4). List of commands is empty when it's a creation of a new macro.

The following actions are available:

- add commands from the command set to the list.
- delete some commands out of the list.
- change the order of the commands in the list.
- edit commands attributes.

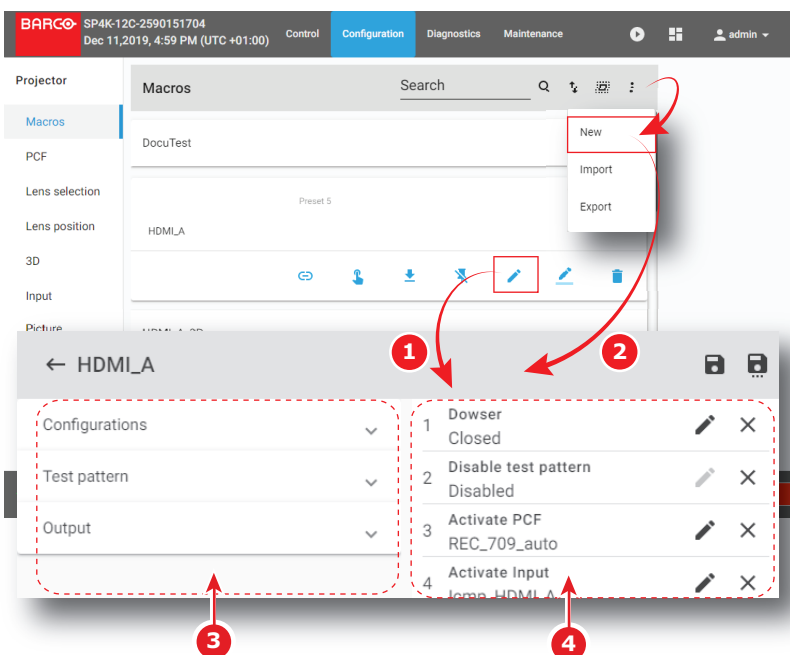

Image 7-4

## About Macros

A macro is a saved sequence of *commands* that can be stored and then easily recalled.

A macro can contain at least:

- an input file
- a screen file
- a PCF file
- a 3D file
- a 2D MCGD file
- a light sensor calibration file
- a lens position file

A macro can be executed in one of the following:

- Click **Execute** directly on the concerned macro in *Control > Projector > Macros*.
- If macro is associated with preset, click on preset button (touch display located on *Input & Communication* side of the projector).
- If the rights of the user are not limited to *Show manager* level, click **Execute** in the contextual menu of the concerned macro in *Configuration > Projector > Macros*.

## About Commands

Commands are basic actions used to trigger mechanisms or features of the projector. Some commands can be relatively basic, such as opening the dowsers, associating an action with a general purpose output, or displaying a pattern. Others, more complex, use settings files to apply specific presets (modify the colorimetry, switch in 3D mode ...).

Commands are grouped by theme in several tabs. The following commands tabs are available:

- Configurations
- Test pattern
- Output

Some commands require additional parameters such as channel number, pulse duration for GPIO or the name of the parameter file to be used by the command. These additional actions are performed by clicking **Edit** located to the right of each command in the command list

### 7.1.4.2 Adding a command to a macro

#### What is possible

Commands list can be completed by new ones, directly selected in the commands set located to the right of the panel. The command can be added at the end of the list (click **Move**) or drag and dropped directly to the right location in the list.

#### How to add

1. While in *Macro editor*, expand the drop down list (reference 1) related to the command category you need to explore.

All available commands (reference 2) are displayed (e.g. Test pattern).

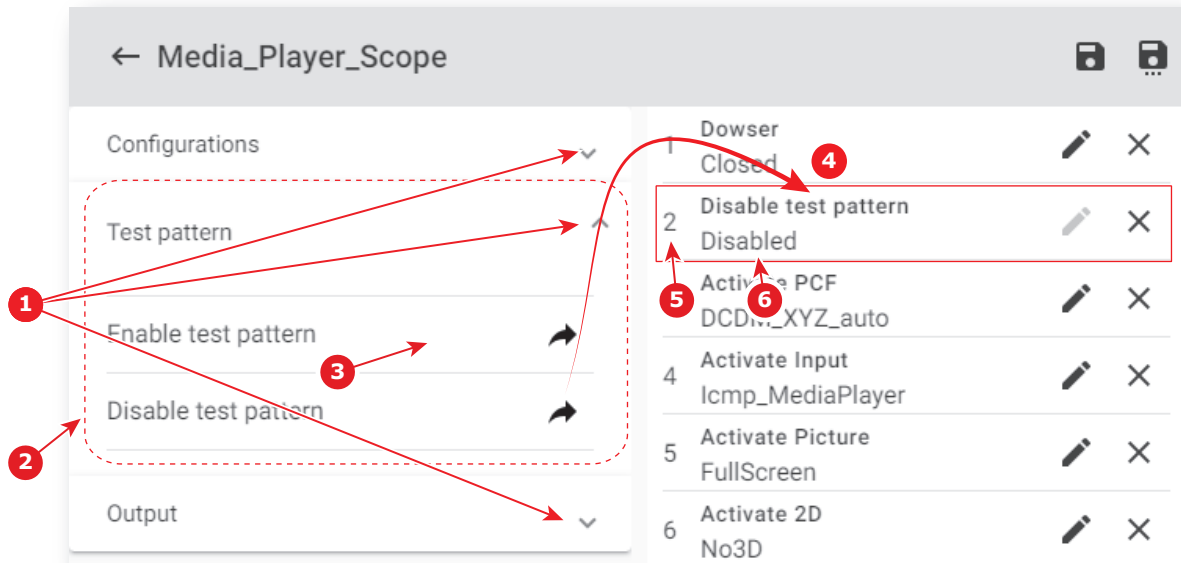

Image 7-5

2. Click **Move** (reference 3) located to the right of the command.

The command is automatically added at the end of the list (reference 4) with the correct sequence number (reference 5).

Parameter status (reference 6) is *Unassigned* as attributes of the command are not settled.

or

drag and drop the command (reference 7) to the right location in the list (reference 8).

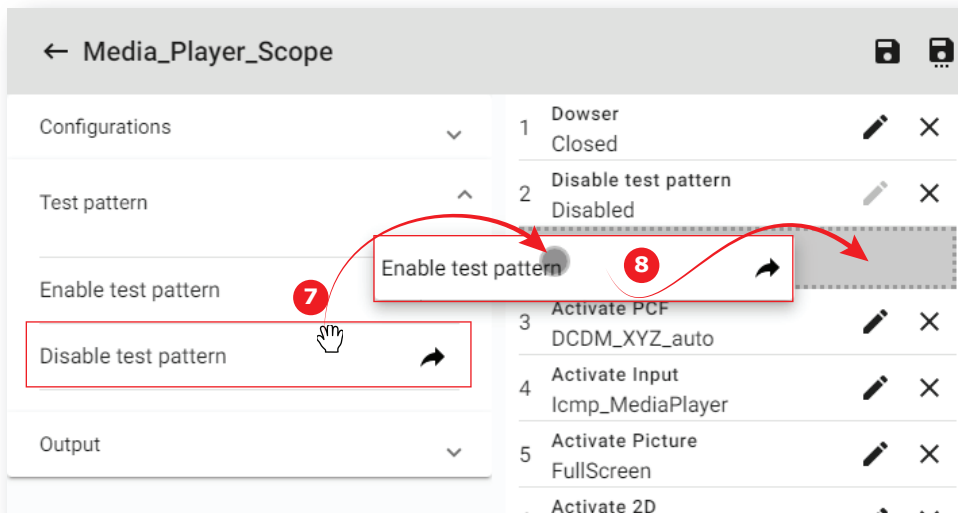

Image 7-6

The command is automatically added to the list at the right position with the correct sequence number. It will not be necessary to move it again in the future.

As for the previous example, parameter status (reference 6) is *Unassigned* as attributes of the command are not settled.

### 7.1.4.3 Deleting a command from a macro file

#### What is possible

Commands in the list may be removed by a simple click.

#### How to delete a command

1. While in *Macro editor*, locate the element you want to remove (reference 1) from the list of commands (reference 2).

The background color of command pointed by the mouse cursor turns to dark when you go through the list.

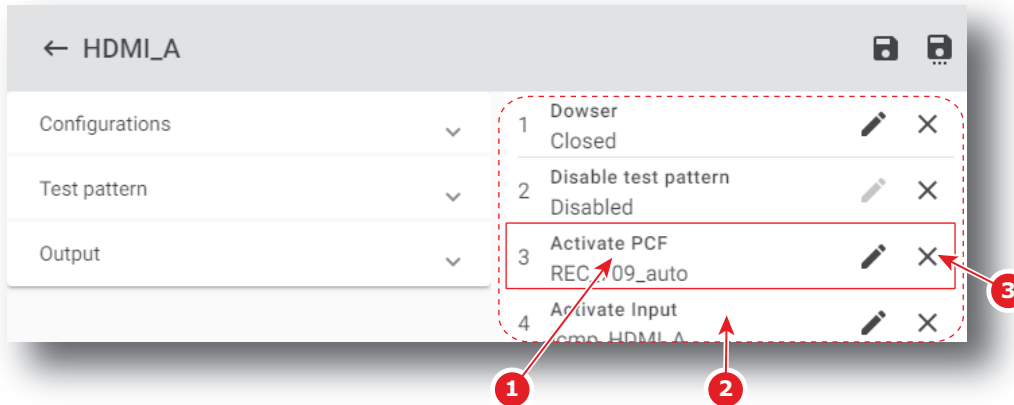

Image 7-7

2. Click **Delete** (reference 3).

The command is removed from the list.

### 7.1.4.4 Editing values of macro commands

#### What is possible

When available, parameters of a command may be defined or modified by a simple click. When no parameter is available for a command, the **edit** button stays greyed.

#### How to edit parameters

1. While in *Macro editor*, locate the item you want to edit (reference 1) in the list of commands (reference 2).

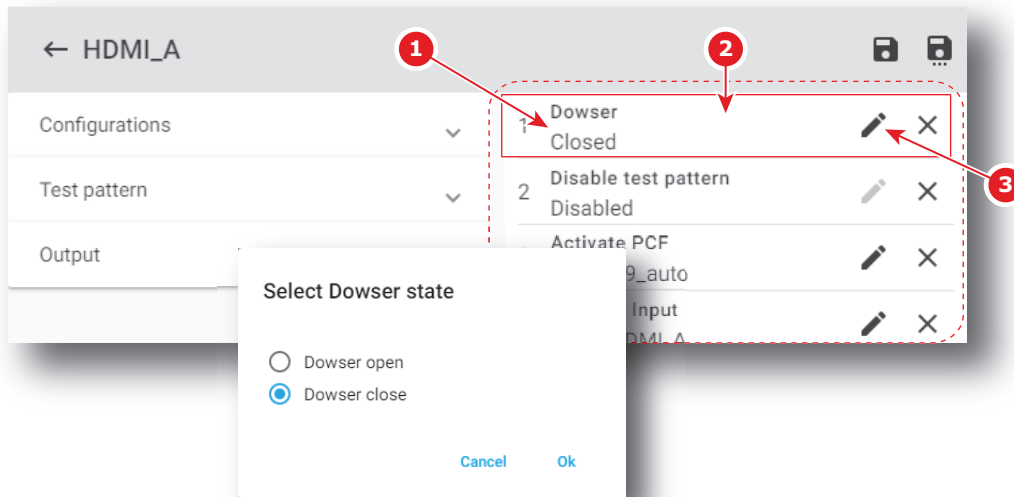

Image 7-8

2. Click the **Edit** icon (reference 3).  
A dialog with parameters related to the command is prompted.  
e.g. Concerning the Dowser state command, the only two choices (**Dowser open** or **Dowser close**) are displayed.
3. Select the desired parameter and confirm with **OK**.  
The edited parameters are updated.

### 7.1.4.5 Changing the order of Macro commands

#### What is possible

Order of the commands in the list may be modified by a simple displacement of elements using the mouse.

#### How to change

1. While in *Macro editor*, locate the element to be moved in the list of commands (reference 1).

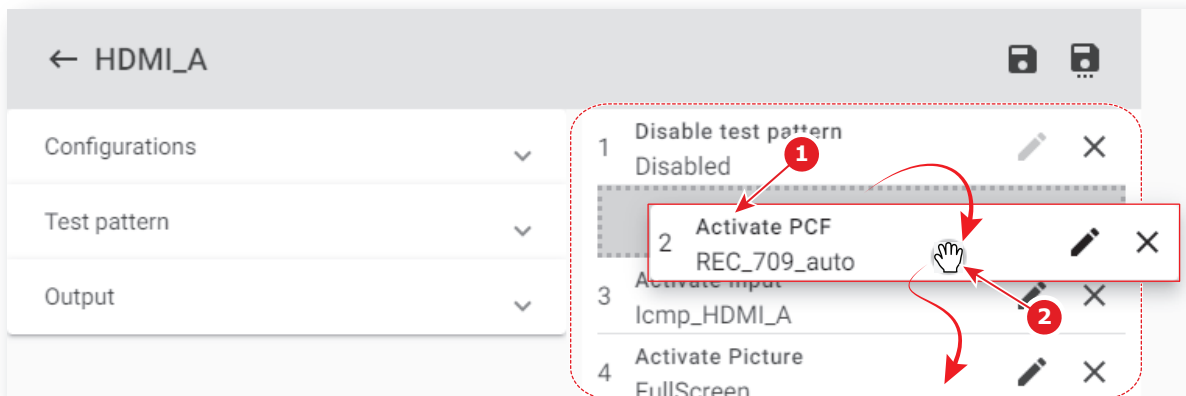

Image 7-9

2. Drag the command (reference 2) from its original position and drop it to the desired position.  
Commands list is automatically reordered.

## 7.1.5 Editing a macro

### Location & access

Menu: Configuration > Projector > Macros

Level: Administrator, Service technician

### How to edit a macro

1. While in *Configuration > Projector > Macros*, click on the macro that you need to change.



Image 7-10

The macro is displayed in its expanded form with menu.

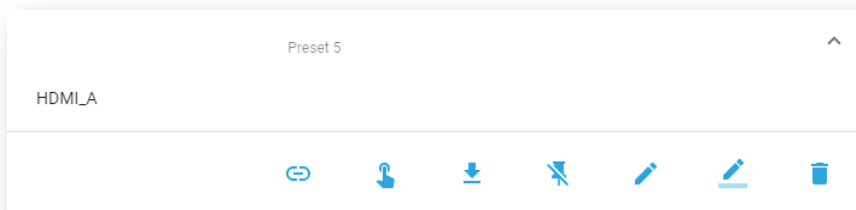

Image 7-11

2. Click **Edit** in the menu. 

The macro is displayed in *Macro editor* (reference 1).

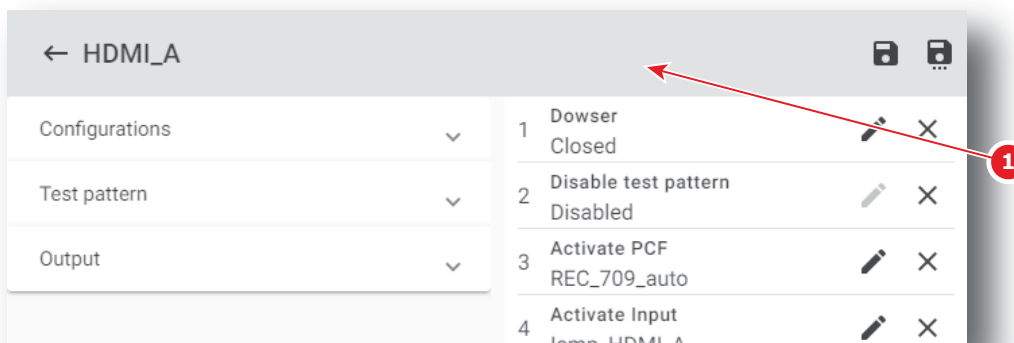

Image 7-12

3. Add, remove or modify commands of the macro. For more information about the *macro editor*, see ["Macro editor"](#), page 90.

The macro is marked by an asterisk (reference 3) if it has been modified.

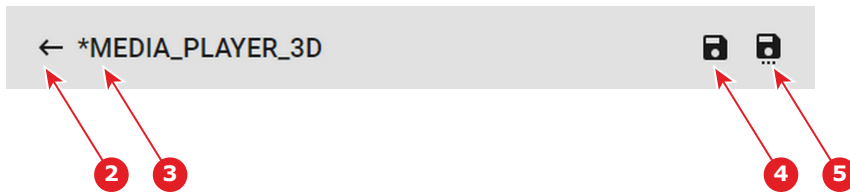



Image 7-13

4. Click **Save** (reference 4) to save the changes made to the macro.  
Old version of macro is now replaced by the new one and asterisk is removed from the name of the macro.

or

Click **Save As** (reference 5) to display the *Save As* window. Enter a name then click **Save** to save modifications.

 **Note:** List of Macros already available in the projector is displayed in this window. Directly click on this list allows you to reuse all or part of an already existing macro name.

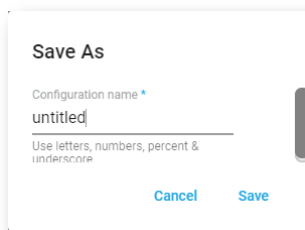

Image 7-14

Previous macro is closed without saving and a new macro is created with the new characteristics.

or

Click **Exit** (reference 2) to leave without saving.

A Confirmation (Dialog Box) verifies if you really want to proceed with this action. Click **OK** if you want to leave without saving.

## 7.1.6 Renaming a macro

### Location & access

Menu: Configuration > Projector > Macros

Level: Administrator, Service technician

### How to rename a macro

1. While in *Configuration > Projector > Macros*, click on the macro that you need to rename.



Image 7-15

The macro is displayed in its expanded form with menu.



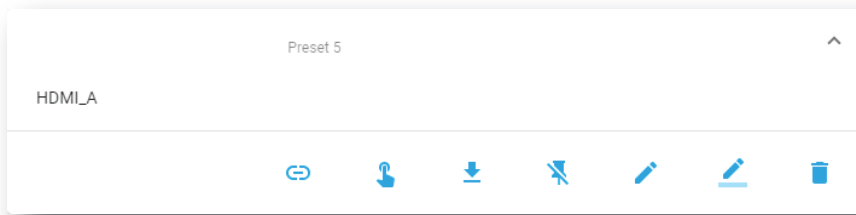



Image 7–16

- Click the **Rename** icon in the menu.  *Rename* window is displayed.

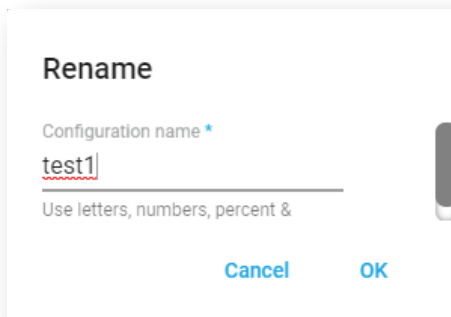

Image 7–17

- Enter a new *macro name* and click **OK**.

## 7.1.7 Activating a macro using the configuration menu

### Location & access

Menu: Configuration > Projector > Macros

Level: Administrator, Service technician

### What is possible

A macro can be activated via one of the preset buttons (touch display located on *Input & Communication* side of the projector) or directly via a click on **Execute** button in the macro contextual menu (see following procedure).



For users who have only limited rights and who do not have access to the setting menu, it is possible to run a macro via the *control* menu. For more information about the macro execution in *control* menu, see [“Activating a macro using the control menu”](#), page 70.

### How to execute a macro

- While in *Configuration > Projector > Macros*, click on the macro you want to activate.



Image 7–18

The macro is displayed in its expanded form with menu.

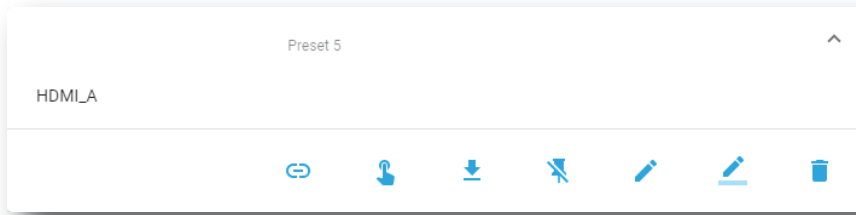

Image 7-19

2. Click **Execute** in the menu.  Status (reference 1) of the macro turns to BUSY and content of the macro is executed.



Image 7-20

3. After few moments execution is done. Status (reference 2) of the macro turns to EXECUTED.



Image 7-21

### When an error occurs

If for some reason the macro does not run correctly, the status turns to COMMANDFAILURE. Click the info balloon (reference 3) to display Macro failure steps.

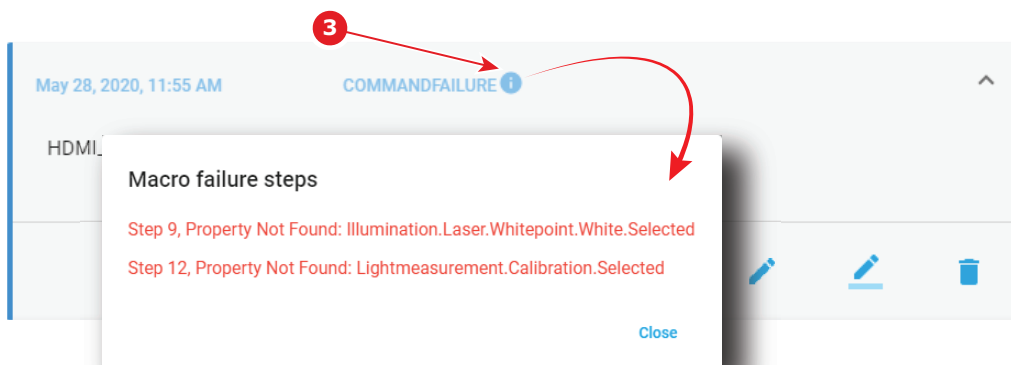

Image 7-22

## 7.1.8 Saving a macro as cue on media server

### What is possible

A macro can be saved as a cue on the media server. The cue will be automatically created on the ICMP under a group called *Projector*.

### Save a macro as cue on media server

1. While in *Configuration > Projector > Macros*, click on the macro that you want to save as cue on media server.



Image 7–23

The macro is displayed in its expanded form with menu.

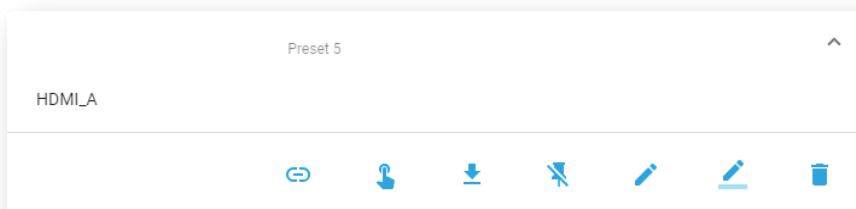

Image 7–24

2. Click **Save as cue** in the menu. 

A cue is created on the ICMP as a user cue under the group *Projector* with the same name as the macro name.

If a cue was already create with this macro name confirmation message appears.

## 7.1.9 Linking a macro to preset button

### Location & access

Menu: *Configuration > Projector > Macros*

Level: Administrator, Service technician

### How to link a macro to preset

1. While in *Configuration > Projector > Macros*, click on the macro you need to link to a preset button.



Image 7–25

The macro is displayed in its expanded form with menu.

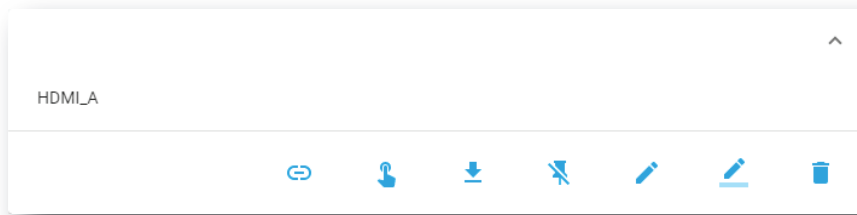

Image 7-26

2. Click **Link to preset** in the menu.



*Link to preset* window is displayed and invite you to select a preset.

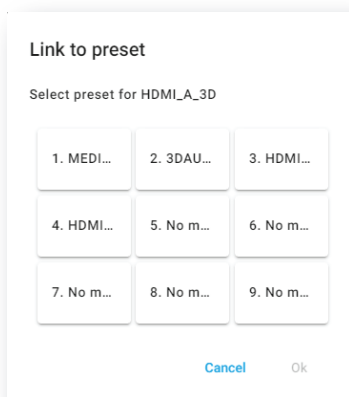

Image 7-27

3. Choose the desired preset button not already linked to a macro (e.g. 5) and confirm with **OK**  
The macro is now associated with the chosen preset button.



Image 7-28

## 7.1.10 Removing a macro from preset buttons

### Location & access

Menu: Configuration > Projector > Macros

Level: Administrator, Service technician

### How to unlink a macro from preset

1. While in *Configuration > Projector > Macros*, click on the macro you want to unlink from preset buttons.



Image 7-29

The macro is displayed in its expanded form with menu.

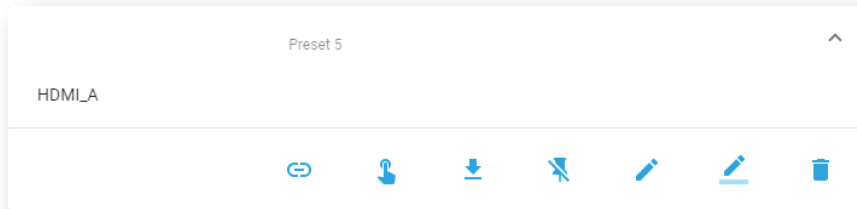

Image 7-30

2. Click **Unlink to preset** in the menu. 

Macro is no longer associated with preset button (e.g. preset 2) and preset number is removed from the macro.



Image 7-31

## 7.1.11 Importing a macro

### Location & access

Menu: Configuration > Projector > Macros

Level: Administrator, Service technician

### How to import an Input file

1. While in *Configuration > Projector > Macros*, click on the macros general menu (reference 1) located on the top right of the list.

The menu is displayed.

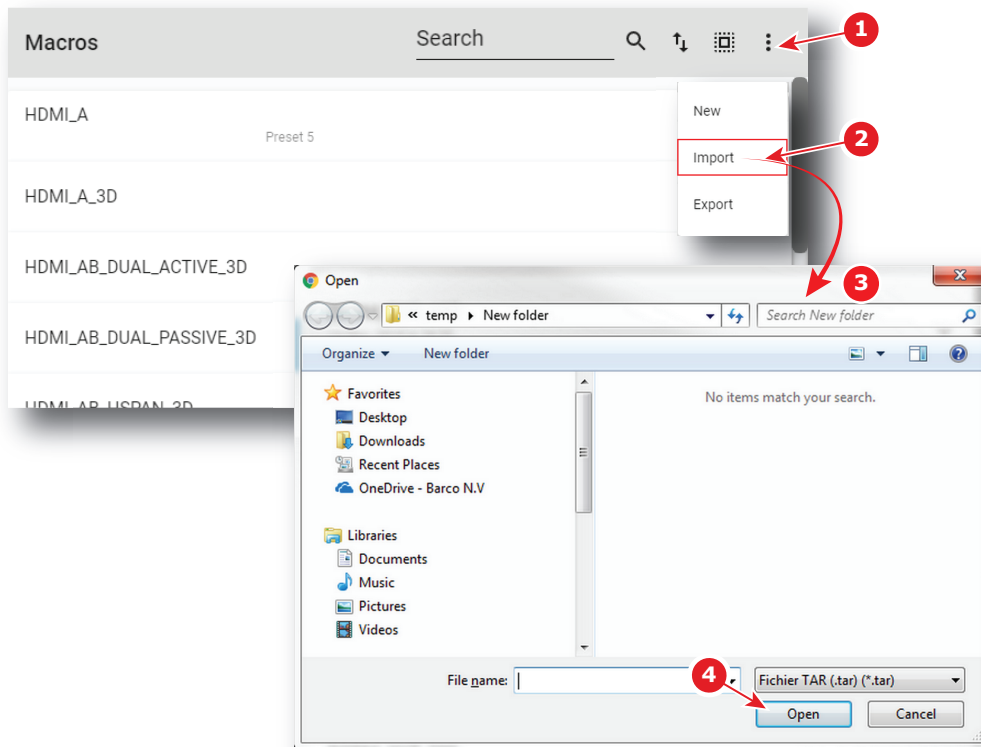

Image 7-32

2. Select **Import** (reference 2) in the menu.  
Open window (reference 3) is displayed
3. Locate and select the macro.
4. Click **Open** (reference 4).  
The macro is imported and added to the list.

## 7.1.12 Exporting a macro

### Location & access

Menu: Configuration > Projector > Macro

Level: Administrator, Service technician

### How to export a macro file

1. While in *Configuration > Projector > Macros*, click on the macro that you want to export.

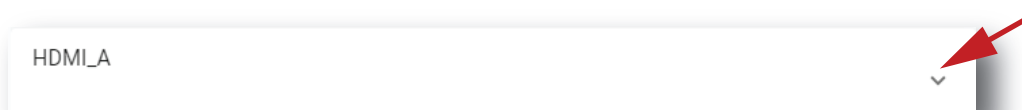

Image 7-33

The macro is displayed in its expanded form with menu.

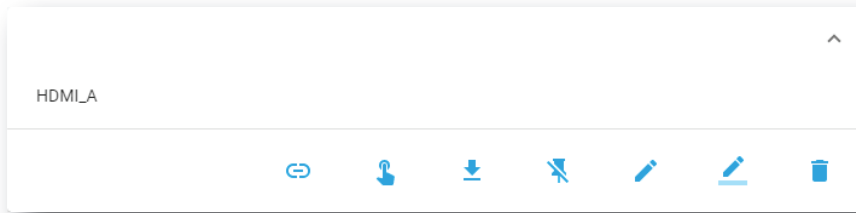



Image 7–34

2. Click **Export** in the menu. 

*Download package* window is displayed during backup package creation.

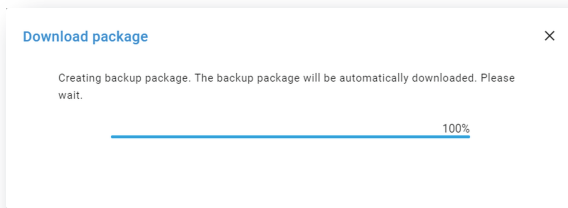

Image 7–35

3. When the backup package is created, it will automatically download to the default *Downloads* directory of your computer (e.g. *MACRO-backup-SP4K-15C-2590153431-2019-04-17T081744Z.tar*).

## 7.1.13 Exporting several macro files in a backup package

### What is possible

Several macro files could be exported at once in a backup package.

### Location & access

Menu: Configuration > Projector > Macros

Level: Administrator, Service technician

### How to create and export backup package of macro files

1. While in *Configuration > Projector > Macros*, click **Select All** (reference 1) and use the check boxes (reference 2) located at right of the macro files in order to select/deselect the files you want to export.

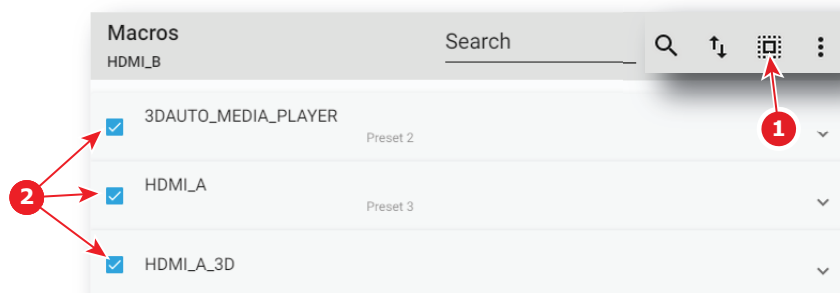

Image 7–36

2. Click on the macro file general menu (reference 3) located on the top right of the list. A menu is displayed.

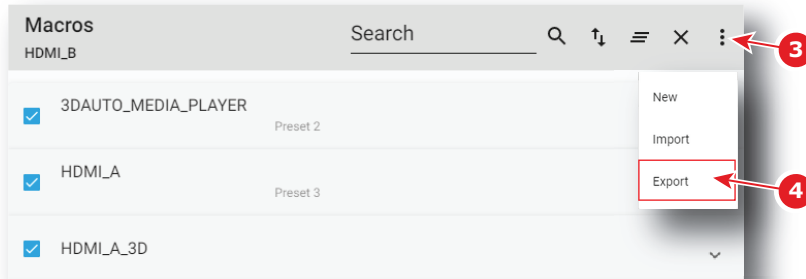

Image 7-37

3. Select **Export** (reference 4) in the menu.  
*Download package* window is displayed during backup package creation.

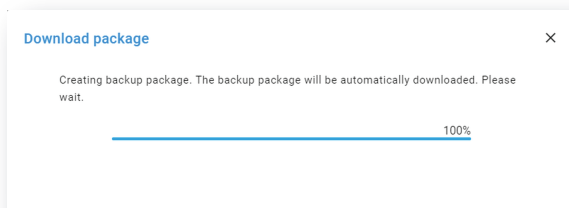

Image 7-38

4. When backup package is created, it is automatically copied in the *Downloads* directory of your computer (e.g. *MACRO-backup-SP4K-15C-2590153431-2019-04-17T081744Z.tar*).

## 7.1.14 Deleting a macro

### Location & access

Menu: Configuration > Projector > Macros

Level: Administrator, Service technician

### How to delete a macro

1. While in *Configuration > Projector > Macros*, click on the macro you want to delete.



Image 7-39

The macro is displayed in its expanded form with menu.

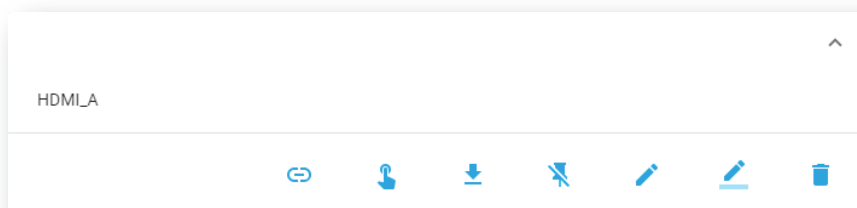

Image 7-40



2. Click the **Delete** icon in the menu and confirm with **OK**.



The macro is removed from the list.

## 7.1.15 Deleting several macro files

### What is possible

Several macro files could be deleted in a single action.

### Location & access

Menu: Configuration > Projector > Macros

Level: Administrator, Service technician

### How to delete several macro files

1. While in *Configuration > Projector > Macros*, click **Select All** (reference 1) and use the check boxes (reference 2) located at right of the macro files in order to select/deselect the files you want to delete.

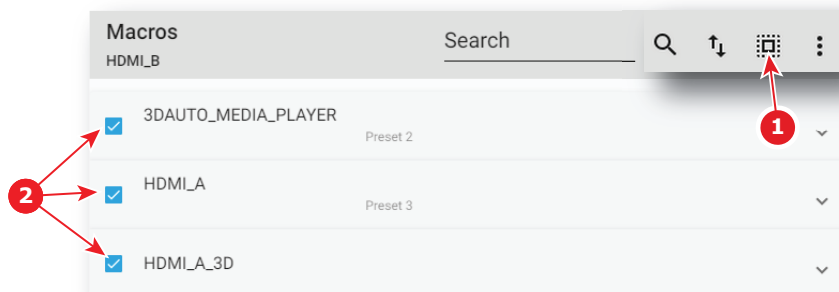

Image 7-41

2. Click on the macro general menu located on the top right of the list, then select **Delete** and confirm with **OK**.

The macro files selected are definitively removed from the list.

## 7.2 PCF

### 7.2.1 About PCF

#### Location & access

Menu: Configuration > Projector > PCF

Level: Administrator, Service technician

#### Overview

This panel allows to manage Projector Configuration Files (PCF). These files contain all data needed to display a certain movie as it is defined by the movie distributor. A batch of default files are installed on the projector during the initial setting with the clone package. Specific PCFs could be delivered with movies or imported manually.

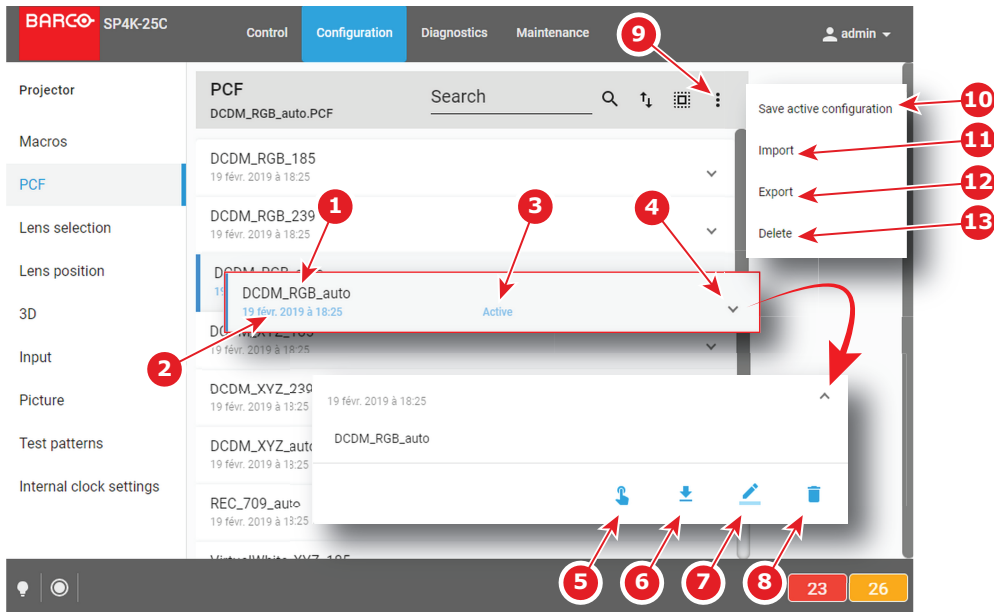

Image 7-42

Each PCF displayed here has a *name* (reference 1). Creation date (reference 2) of the PCF file is displayed just under its name. When a PCF is activated the status (reference 3) turns to *Active* and its name is noticed on top of the list.

Clicking on a PCF (reference 4) in this list allows to show it in its expanded form and displays a contextual menu.

Following actions are available in this menu:

- **Activate** (reference 5) allows to activate the PCF.
- **Export** (reference 6) copies the .PCF file in the *Downloads* directory of your computer.
- **Rename** (reference 7) allows to modify the name of the PCF.
- **Delete** (reference 8) allows to remove the PCF from the list.

Clicking on menu (reference 9) displays the PCF general menu.

Following actions are available in this menu:

- **Save active configuration** (reference 10) allows to create a new PCF based on current configuration.
- **Import** (reference 11) allows to import a PCF alone (one single file), or a package of PCF (.tar) with several files inside.
- **Export** (reference 12) creates a downloadable backup package that contains all PCF selected in the list. then copies this package in the *Downloads* directory of your computer.
- **Delete** (reference 13) allows to remove several PCF selected in the list.

## 7.2.2 Creating a PCF with active configuration

### Location & access

Menu: Configuration > Projector > PCF

Level: Administrator, Service technician

### How to create a PCF with active configuration

1. While in *Configuration > Projector > PCF*, click on the PCF general menu (reference 1) located on the top right of the list.  
PCF menu is displayed.

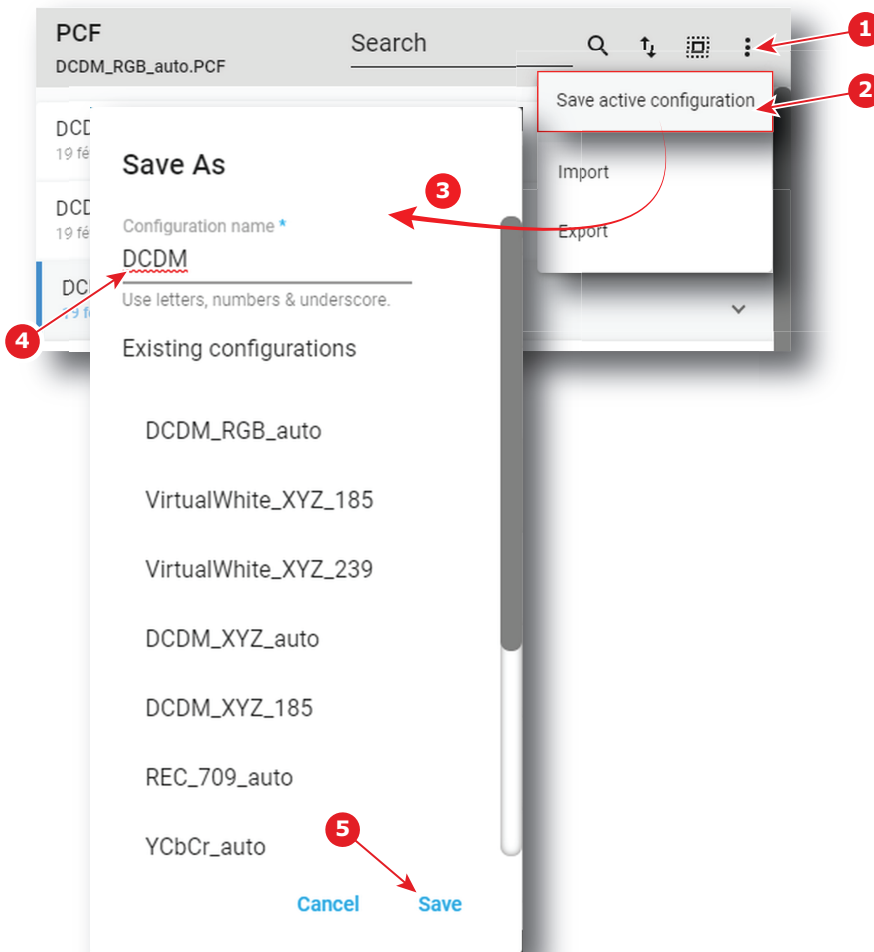

Image 7-43

2. Select **Save active configuration** (reference 2) in the menu.  
Save As window (reference 3) is displayed
3. Enter a PCF file name (reference 4)  
or  
Select a name already existing in the list.
4. Click **Save** (reference 5).  
PCF is created with current active configuration and added to the PCFs list.

## 7.2.3 Activating a PCF

### Location & access

Menu: Configuration > Projector > PCF

Level: Administrator, Service technician

### What is possible

Usually a PCF file is activated via a macro but it is possible to directly activate a PCF by clicking on **Activate** in the contextual menu.

### How to activate

1. While in *Configuration > Projector > PCF*, find and click on the PCF you want to activate.

The PCF is displayed in its expanded form with menu.

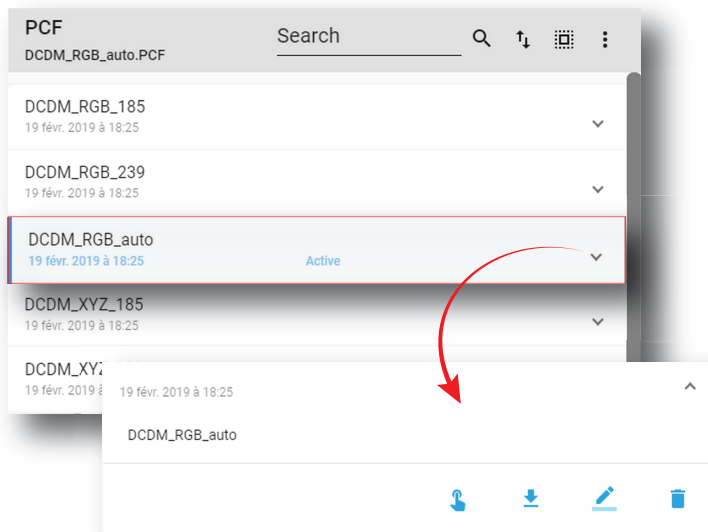

Image 7-44

2. Click **Activate** in the menu.



The new configuration is applied. Status of the PCF turns to *Active* and its name is noticed on top of the list.

## 7.2.4 Renaming a PCF

### Location & access

Menu: Configuration > Projector > PCF

Level: Administrator, Service technician

### How to rename a PCF

1. While in *Configuration > Projector > PCF*, find and click on the PCF you want to rename.

The PCF is displayed in its expanded form with menu.

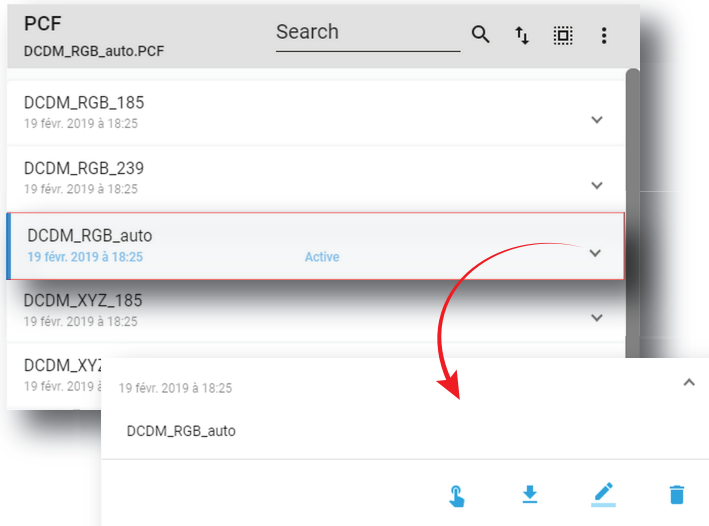



Image 7–45

- Click **Rename** in the menu.   
Rename window is displayed.

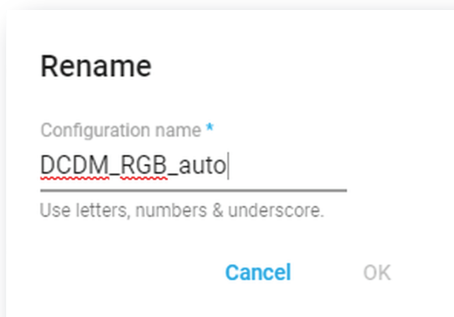

Image 7–46

- Enter a new *Configuration name* and click **OK**.

## 7.2.5 Importing a PCF

### Location & access

Menu: Configuration > Projector > PCF

Level: Administrator, Service technician

### How to import a PCF

- While in *Configuration > Projector > PCF*, click on the PCF general menu (reference 1) located on the top right of the list.  
PCF menu is displayed.

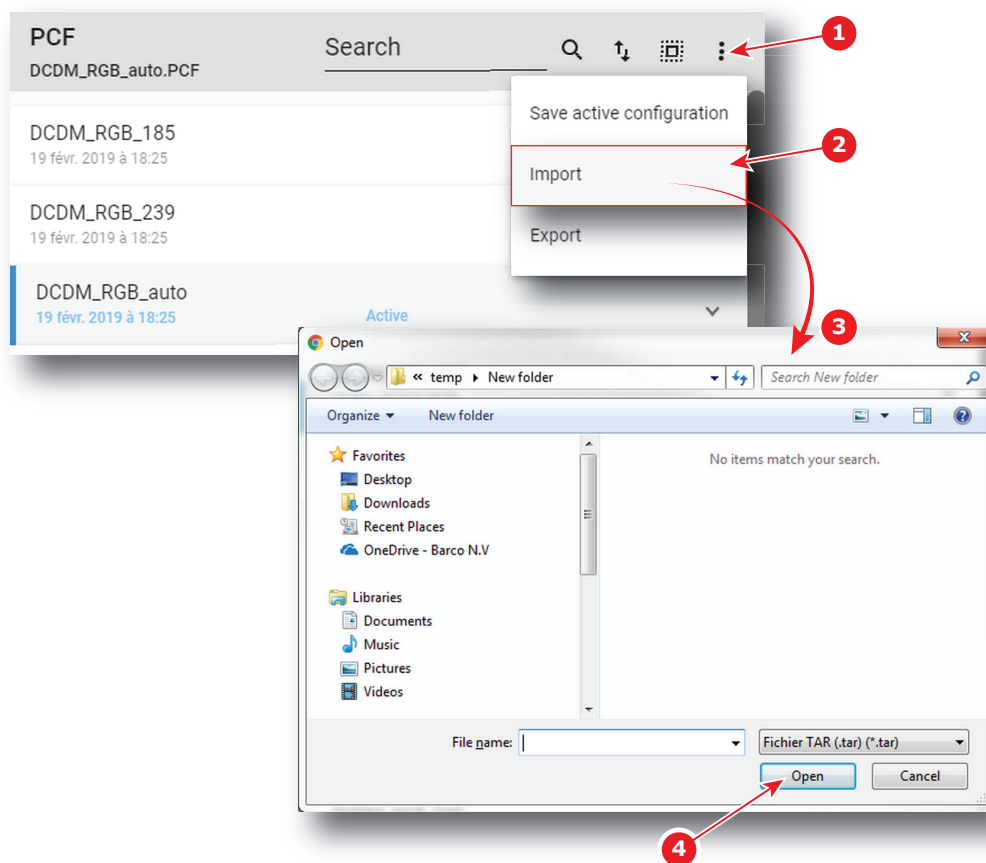

Image 7-47

2. Select **Import** (reference 2) in the menu.  
Open window (reference 3) is displayed
3. Locate and select a single PCF file (.PCF) or a package of PCF files (.tar).
4. Click **Open** (reference 4).  
Selected files are imported and added to the PCFs list.



If a file has the same name as a file already present, a confirmation will be required before overwriting.

## 7.2.6 Exporting a PCF

### Location & access

Menu: Configuration > Projector > PCF

Level: Administrator, Service technician

### How to export a PCF

1. While in *Configuration > Projector > PCF*, find and click on the PCF you want to export.  
The PCF is displayed in its expanded form with menu.

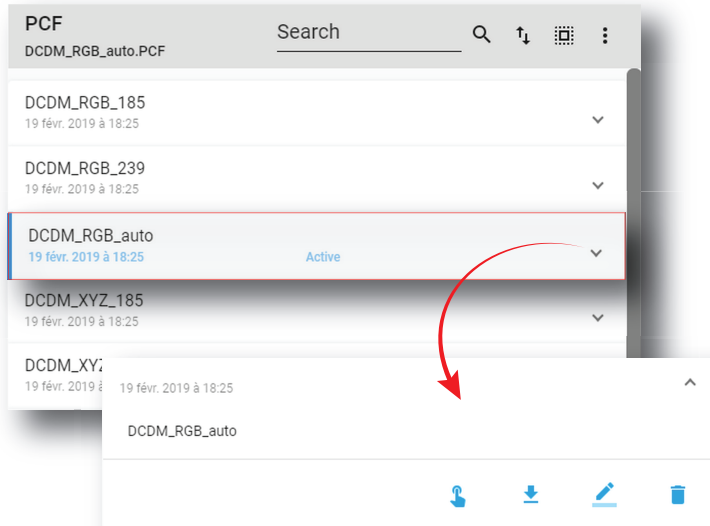

Image 7-48

2. Click **Export** in the menu.



PCF file is created and automatically copied in the *Downloads* directory of your computer (e.g. *DCDM\_RGB\_auto.PCF*).

## 7.2.7 Exporting several PCF in a backup package

### Location & access

Menu: Configuration > Projector > PCF

Level: Administrator, Service technician

### What is possible

Several PCF files could be exported at once in a backup package.

### How to create and export backup package of PCF

1. While in *Configuration > Projector > PCF*, click **Select All** (reference 1) and use the check boxes (reference 2) located at right of the PCF files in order to select/deselect the PCF files you want to export.

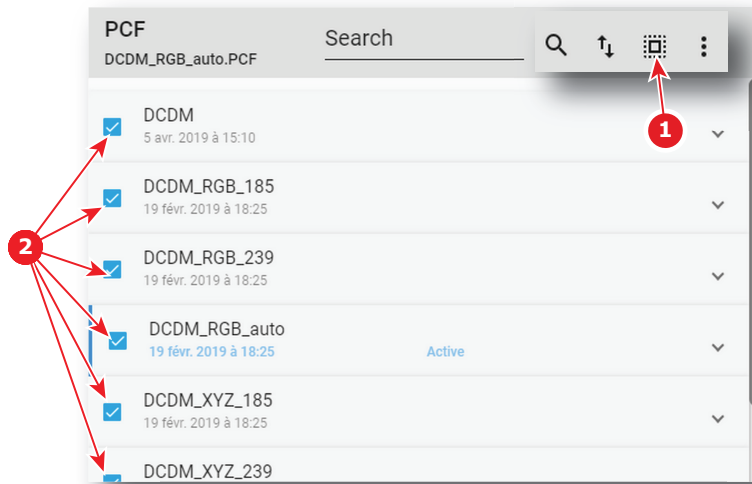

Image 7-49

2. Click on the PCF general menu (reference 3) located on the top right of the list. PCF menu is displayed.

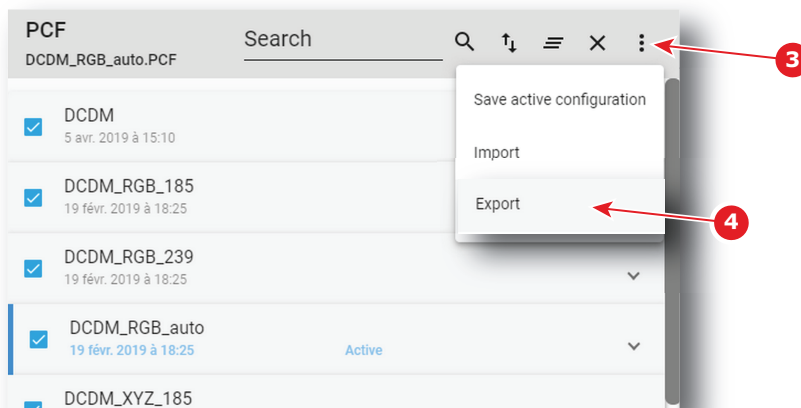

Image 7-50

3. Select **Export** (reference 4) in the menu. *Download package* window is displayed during backup package creation.

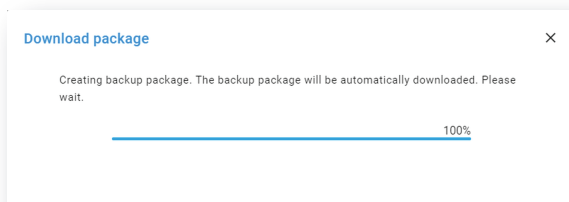

Image 7-51

4. When backup package is created, it is automatically copied in the *Downloads* directory of your computer (e.g. *pcf-backup-SP4K-15C-2590153431-2019-04-09T134843Z.tar*).



## 7.2.8 Deleting a PCF

### Location & access

Menu: Configuration > Projector > PCF

Level: Administrator, Service technician

### How to delete a PCF

1. While in *Configuration > Projector > PCF*, find and click on the PCF you want to delete.  
The PCF is displayed in its expanded form with menu.

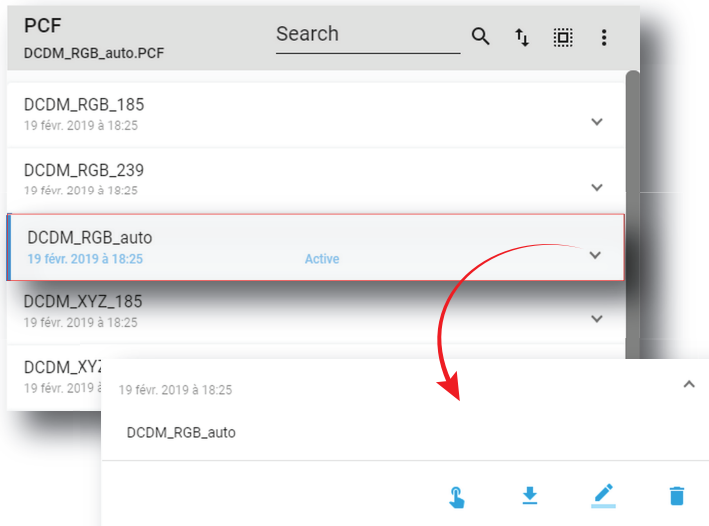

Image 7–52

2. Click **Delete** in the menu. 

A confirmation message appears.

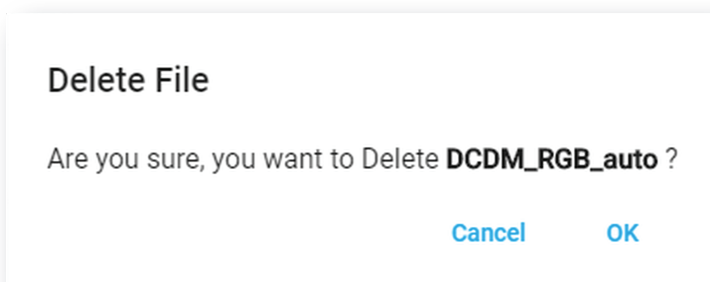

Image 7–53

3. Click **OK**.

File is removed from the list.

## 7.2.9 Deleting several PCF

### Location & access

Menu: Configuration > Projector > PCF

Level: Administrator, Service technician

## How to delete several PCF

1. While in *Configuration > Projector > PCF*, click **Select All** (reference 1) and use the check boxes (reference 2) located at right of the PCF files in order to select/deselect the PCF files you want to delete.

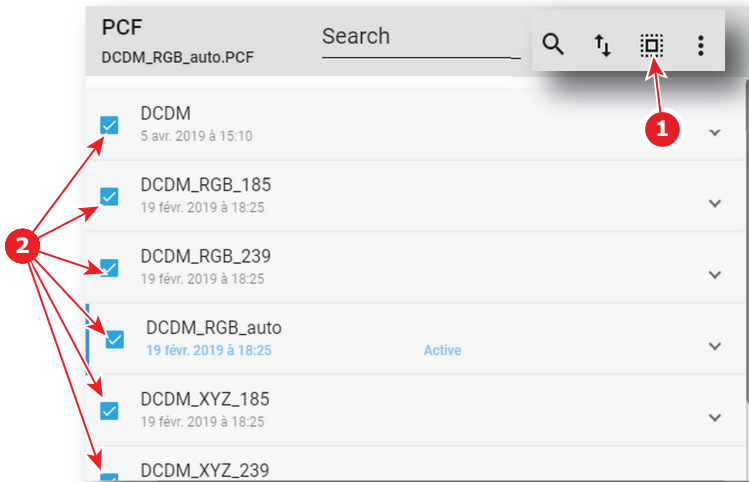

Image 7-54

2. Click on the PCF general menu located on the top right of the list, then select **Delete** and confirm with **OK**. The PCF files selected are definitively removed from the list.

## 7.3 Lens selection

### 7.3.1 About Lens selection

#### Location & access

Menu: Configuration > Projector > Lens selection

Level: Administrator, Service technician

#### Overview

This panel allows to select a lens type (in the list of lens types available for the projector) and execute lens calibration.

Each item in the list represents a lens type.

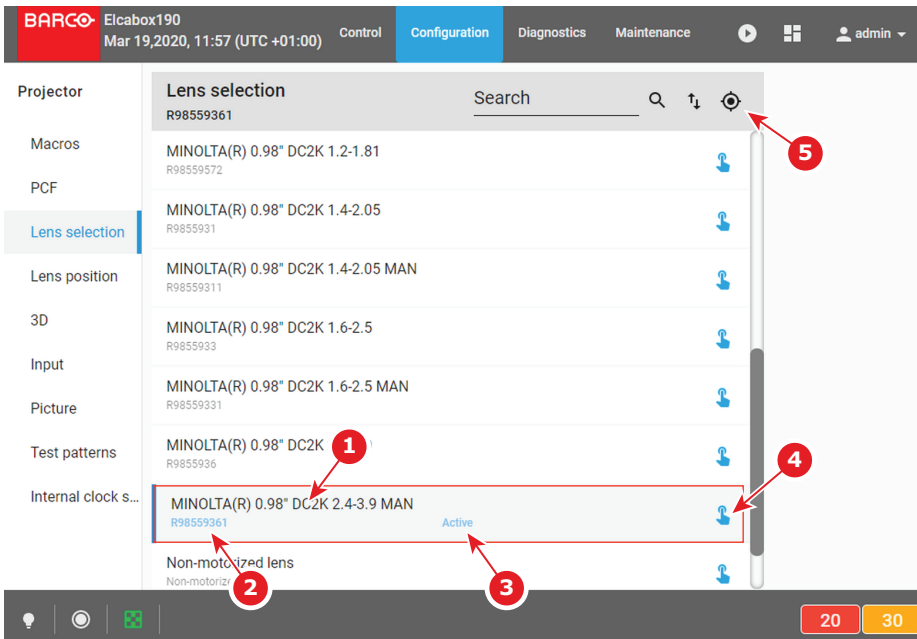

Image 7–55

Each item has a complete lens description (reference 1). Reference number (reference 2) of the lens is displayed just under this description. When a lens type is activated the status (reference 3) turns to *Active* and the reference number of the lens is noticed on top of the list.

Click **Active** (reference 4) allows to activate the lens type.

Click **calibrate** (reference 5) located on top of the list allows to display *calibrate* panel in order to realize a lens calibration or consult the calibration history (overview on the last performed calibration).

## 7.3.2 Activating a lens

### Importance of activating the correct lens

Pay attention to selecting the correct lens mounted in the projector. Certain available lenses are focused by shifting the lens holder of the projector while other lenses are focused using the internal focus motor of the lens.

By activating the correct lens, the system will activate the correct focus adjustment process. Choosing an incorrect lens may lead to an unfocused picture or a misalignment of the lens holder.

### Location & access

Menu: Configuration > Projector > Lens selection

Level: Administrator, Service technician

### How to activate

1. While in *Configuration > Projector > Lens selection*, click on the activate icon located in the right corner of the desired lens type.

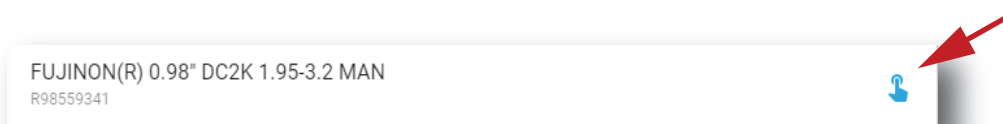

Image 7–56

The lens type is now activated :

- Reference number of the lens is noticed on top of the list (reference 1).
- Status (reference 2) turns to *Active*.

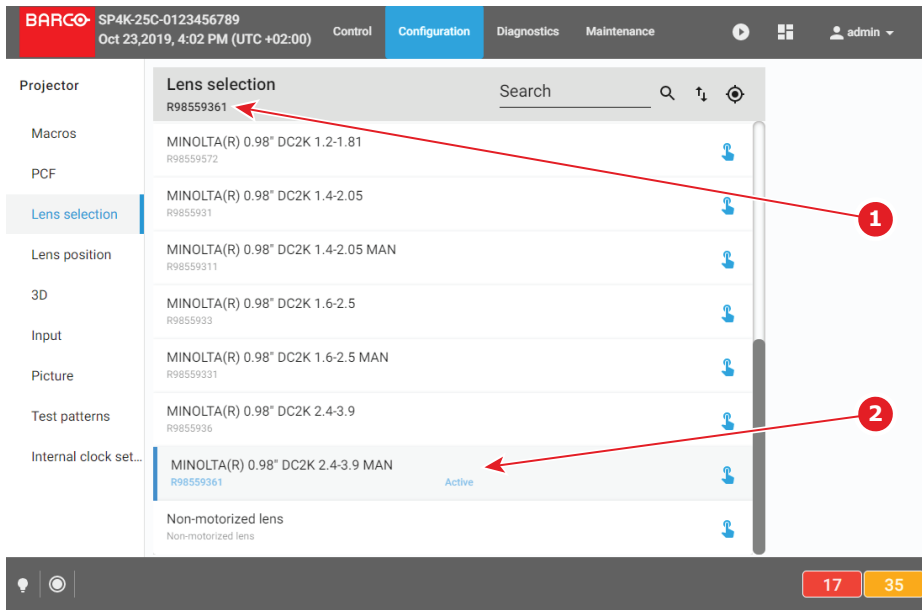

Image 7-57

2. The system will ask you to calibrate the lens and forward you to the calibration menu. For more info, see [“Calibrating a lens”, page 116.](#)

### 7.3.3 Calibrating a lens

#### Location & access

Menu: Configuration > Projector > Lens selection

Level: Administrator, Service technician

#### About lens calibration

The lens calibration consists of moving the lens to a reference point and either returning it to the original position or to the mid position.

Each time a lens is inserted in a projector it is necessary to perform a lens calibration.

In case the projector has lost its original reference point for the lens, the projector will automatically perform a lens calibration at boot time.

#### Lens calibration history

The table on the top of the calibration panel gathers lens calibration information like time and date of the last performed calibration and the status of that calibration.

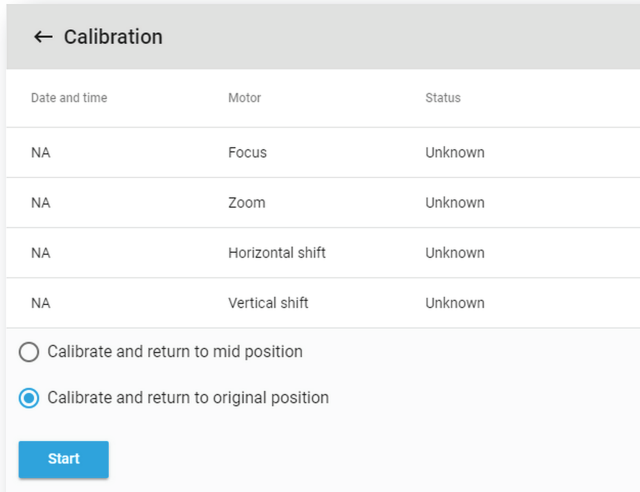

Image 7–58

### How to calibrate a lens

1. While in *Configuration > Projector > Lens* , activate the desired lens.
2. Click on the **calibrate** icon located on top of the lens selection list.

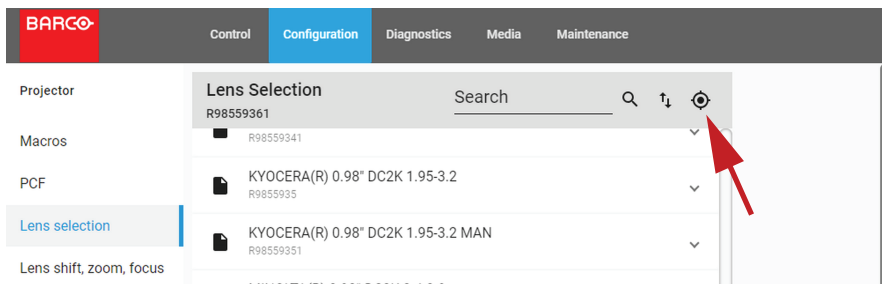

Image 7–59

The Calibration panel is displayed.

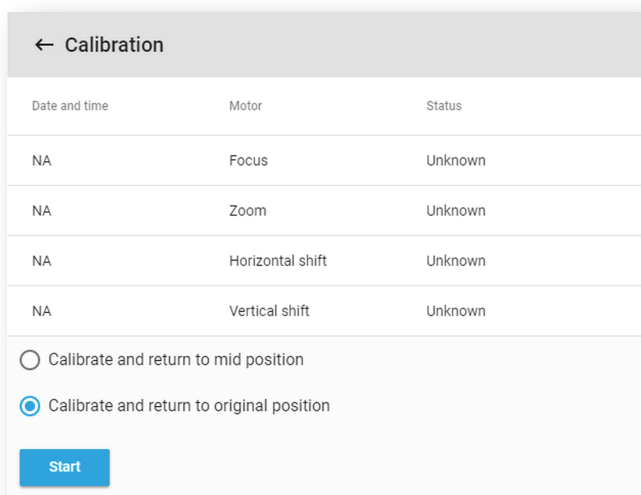

Image 7–60

3. Select one of the following calibration options:
  - *Calibrate and return to mid position* allows the lens to return to the middle position once the lens has reached the reference point.
  - *Calibrate and return to original position* allows the lens to return to the position before the calibration once the lens has reached the reference point.
4. Click **Start**.

The calibration will start. A message will display the status of the calibration.

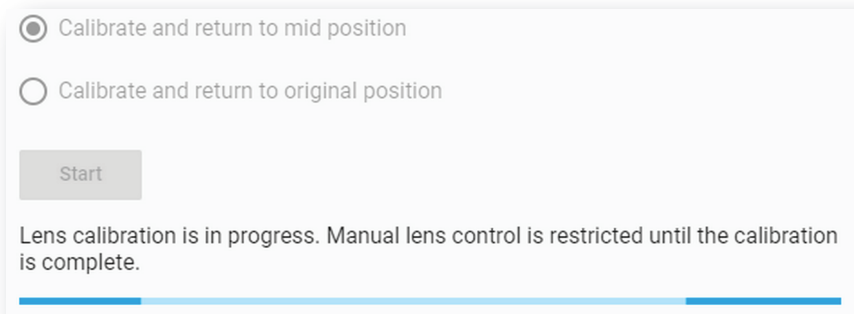

Image 7-61

5. After a while, the calibration will end and the page will automatically refresh.

The result of the calibration will be displayed in the calibration table (both failure and success).

## 7.4 Lens position

### 7.4.1 About Lens position

#### Location & access

Menu: Configuration > Projector > Lens position

Level: Administrator, Service technician

#### Overview

This panel allows to manage *lens position* files. These files contain zoom, shift and focus information. This files must be created during projector installation and apply before each playout via a macro.

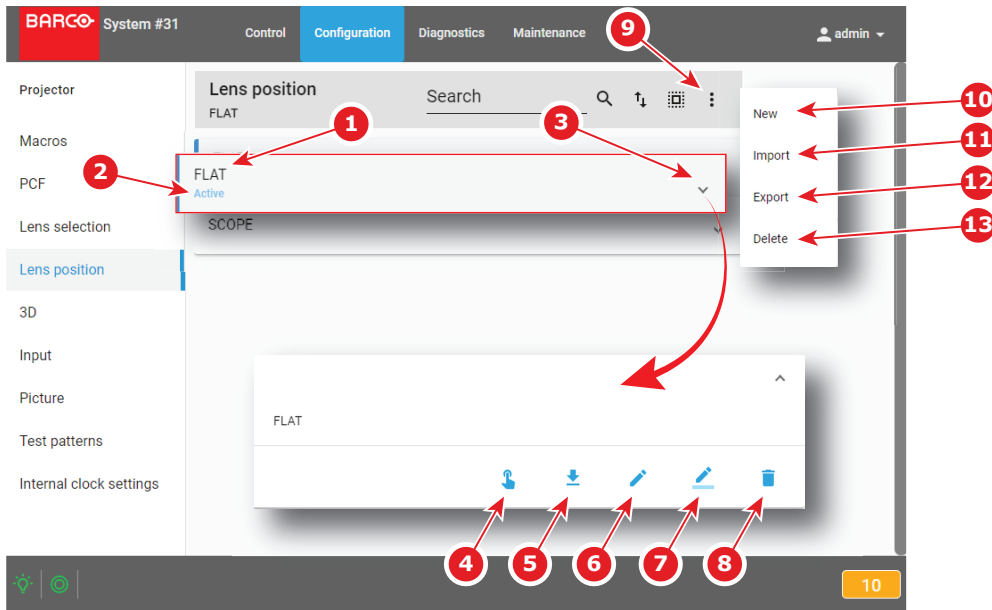

Image 7–62

Each *lens position* file displayed here has a *name* (reference 1). When a *lens position* file is activated the status (reference 2) turns to *Active* and its name is noticed on top of the list.

Clicking on a file (reference 3) in this list allows to show it in its expanded form and displays a contextual menu.

Following actions are available in this menu:

- **Activate** (reference 4) allows to activate the *lens position* file.
- **Export** (reference 5) creates a downloadable backup package.
- **Edit** (reference 6) allows to modify the *lens position* file.
- **Rename** (reference 7) allows to rename the *lens position* file.
- **Delete** (reference 8) allows to remove the file from the list.

Clicking on menu (reference 7) displays the *lens position* general menu.

Following actions are available in this menu:

- **New** (reference 10) allows to create a new *lens position* file based on current configuration.
- **Import** (reference 11) allows to import *lens position* file.
- **Export** (reference 12) creates a downloadable backup package that contains all *lens position* files selected in the list.
- **Delete** (reference 13) allows to remove several *lens position* files selected in the list.



Click on the name of the active file located on the top of the list to open it directly in edit mode.

## 7.4.2 Creating a lens position file

### Location & access

Menu: Configuration > Projector > Lens position

Level: Administrator, Service technician

### How to create lens position file from an active configuration

1. While in *Configuration > Projector > Lens position*, click on the Lens position general menu (reference 1) located on the top right of the list.  
Lens position menu is displayed.

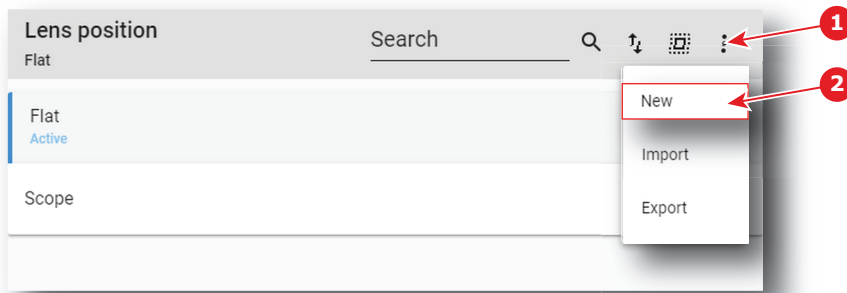

Image 7-63

2. Select **New** (reference 2) in the menu.

*Lens control* panel is displayed.

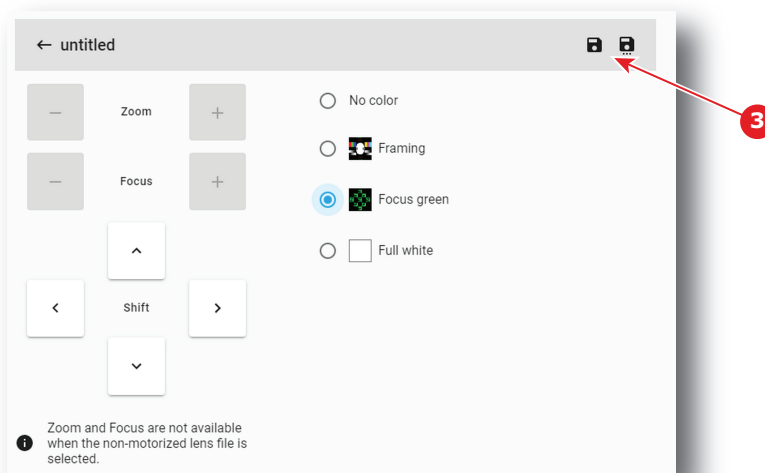



Image 7-64

3. Select a test Pattern (e.g. Focus green) and adjust lens settings (lens shift, focus and zoom) if needed. For more detail concerning lens settings in *lens control* panel, please see [“Light, dowser, lens”, page 71](#).

 *Note:* Zoom and Focus are not available when the non-motorized lens file is selected.

4. Click **Save** (reference 3) to prompt the Save As window

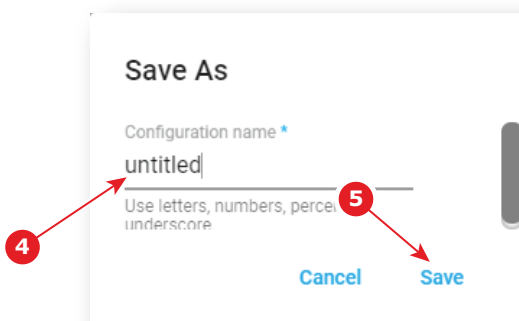

Image 7-65

5. Enter a lens position file name (reference 4)

or



if a list of names appears in the window, you can also select an existing name to overwrite.

6. Click **Save** (reference 5).

A lens position is created with current active configuration and added to the lens position list.

### 7.4.3 Editing a Lens position file

#### Location & access

Menu: Configuration > Projector > Lens position

Level: Administrator, Service technician

#### How to edit

1. While in Configuration > Projector > Lens position, find and click on the lens position file you want to activate.

The lens position file is displayed in its expanded form with menu.

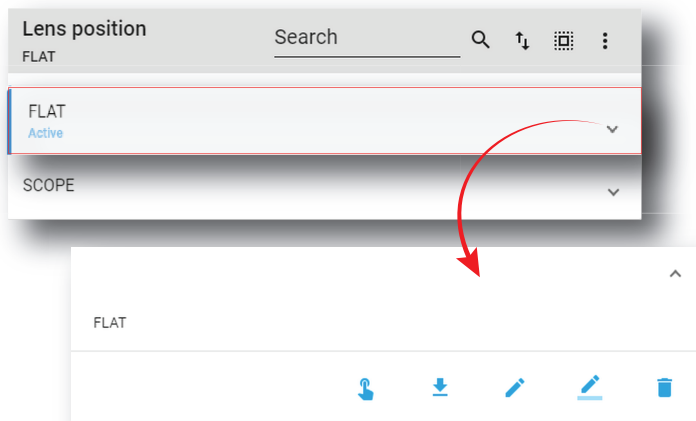



Image 7-66

2. Click **Edit** in the menu. 

*Lens control* panel is displayed.

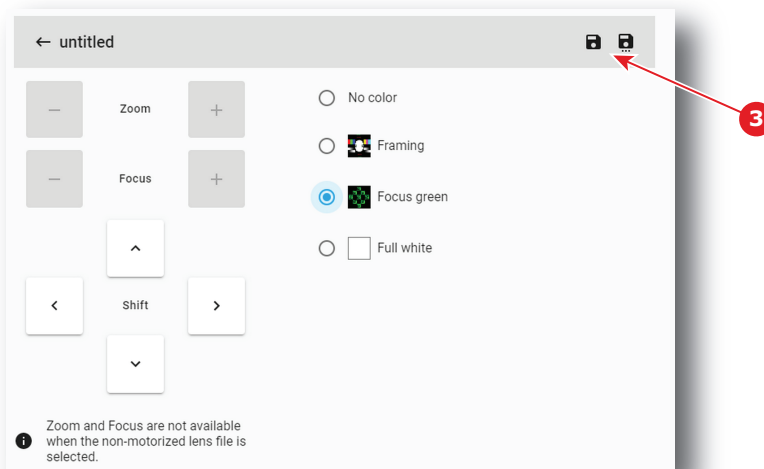



Image 7-67

3. Select a test Pattern (e.g. Focus green) and adjust lens settings (lens shift, focus and zoom) if needed. For more detail concerning lens settings in *lens control* panel, please see “[Light, dowser, lens](#)”, page 71.

 *Note:* Zoom and Focus are not available when the non-motorized lens file is selected.

4. Click **Save** (reference 3).

## 7.4.4 Activating a lens position file

### What is possible

Usually a lens position file is activated via a macro but it is possible to directly activate it by clicking on **Activate** in the contextual menu.

### How to activate

1. While in Configuration > Projector > Lens position, find and click on the lens position file you want to activate.

The lens position file is displayed in its expanded form with menu.

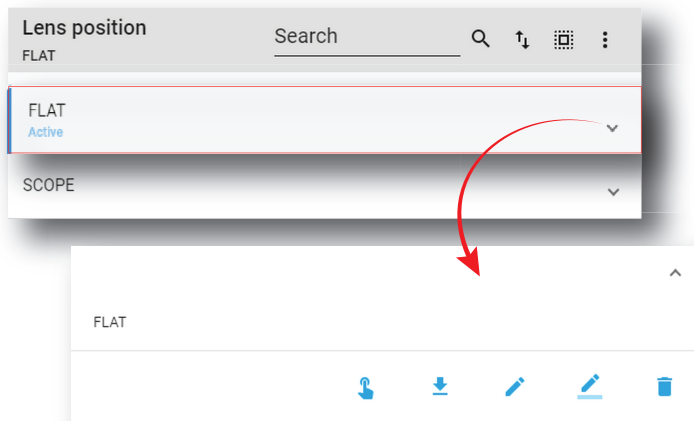

Image 7-68

2. Click **Activate** in the menu. 

The new configuration is applied. Status of the lens position file turns to *Active* and its name is noticed on top of the list.



Click on the name of the active file located on the top of the list to open it directly in edit mode.

## 7.4.5 Renaming a lens position file

### How to rename

1. While in *Configuration > Projector > 3D*, find and click on the 3D file you want to rename.

The 3D file is displayed in its expanded form with menu.

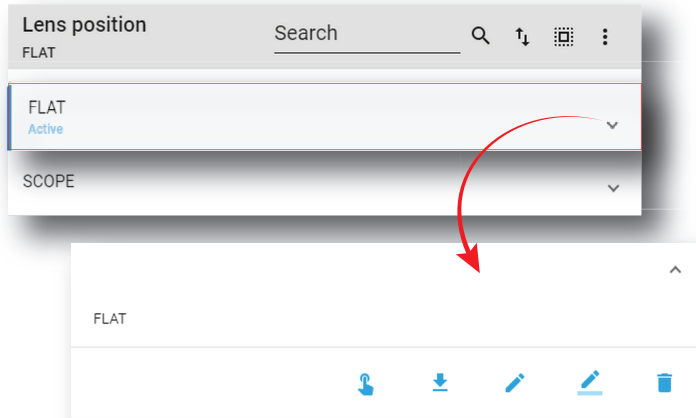



Image 7-69

2. Click the **Rename** icon.  The *Rename* window is prompted.

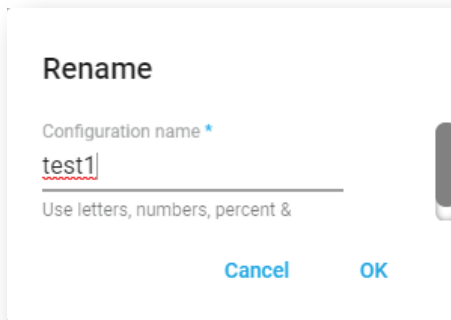

Image 7-70

3. Enter a new name and confirm with **OK**.

## 7.4.6 Importing a Lens position file

### Location & access

Menu: Configuration > Projector > Lens position

Level: Administrator, Service technician

### How to import a Lens position file

1. While in *Configuration > Projector > Lens position*, click on the Lens position general menu (reference 1) located on the top right of the list.  
Lens position menu is displayed.

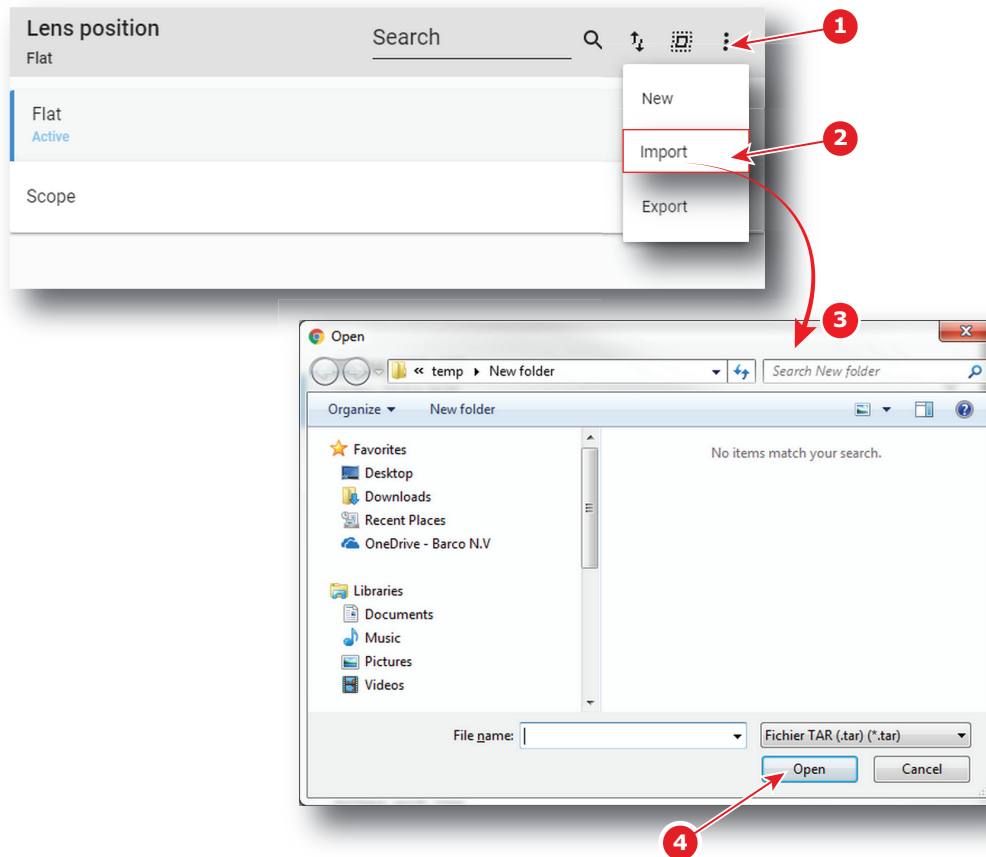

Image 7-71

2. Select **Import** (reference 2) in the menu.  
Open window (reference 3) is displayed
3. Locate and select the lens position file.
4. Click **Open** (reference 4).  
Lens position is imported and added to the lens positions list.

## 7.4.7 Exporting a Lens position file

### Location & access

Menu: Configuration > Projector > Lens position

Level: Administrator, Service technician

### How to export lens position file

1. While in *Configuration > Projector > Lens position*, find and click on the lens position file you want to export.  
The lens position file is displayed in its expanded form with menu.

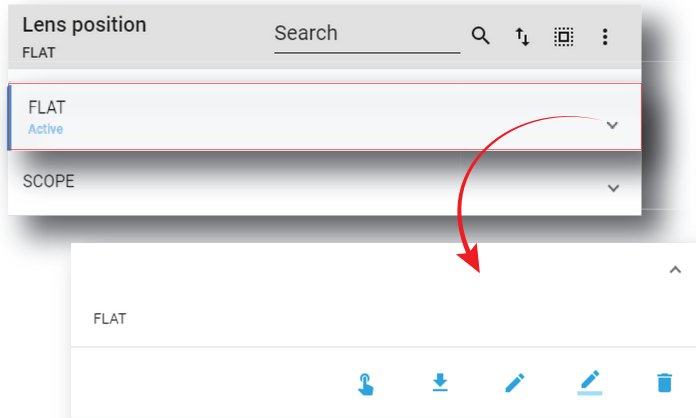



Image 7–72

2. Click **Export** in the menu.    
*Download package* window is displayed during backup package creation.

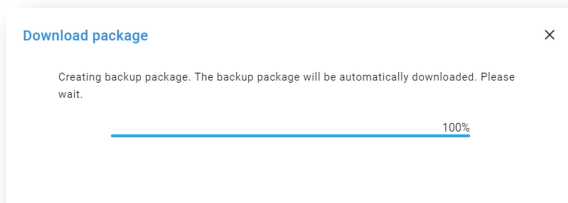

Image 7–73

3. When backup package is created, it is automatically copied in the *Downloads* directory of your computer (e.g. *OPTICS-backup-SP4K-15C-2590153431-2019-04-09T142045Z.tar*).

## 7.4.8 Exporting several lens position files in a backup package

### Location & access

Menu: Configuration > Projector > Lens position

Level: Administrator, Service technician

### What is possible

Several lens position files could be exported at once in a backup package.

### How to create and export backup package of lens position file

1. While in *Configuration > Projector > Lens position*, click **Select All** (reference 1) and use the check boxes (reference 2) located at right of the lens position files in order to select/deselect the files you want to export.

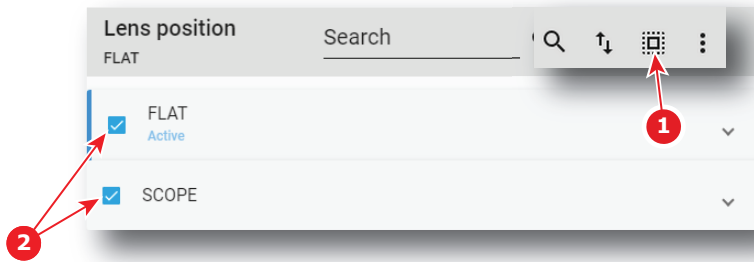

Image 7-74

2. Click on the lens position general menu (reference 3) located on the top right of the list. Lens position menu is displayed.

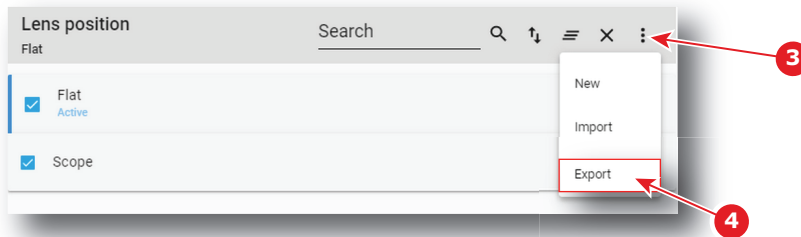

Image 7-75

3. Select **Export** (reference 4) in the menu. *Download package* window is displayed during backup package creation.

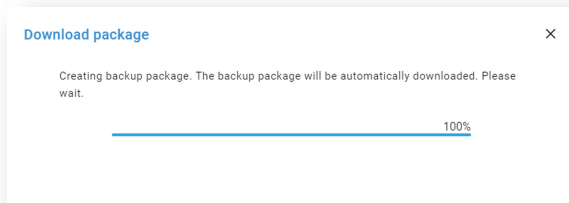

Image 7-76

4. When backup package is created, it is automatically copied in the *Downloads* directory of your computer (e.g. *OPTICS-backup-SP4K-15C-2590153431-2019-04-09T142045Z.tar*).

## 7.4.9 Deleting a Lens position file

### Location & access

Menu: Configuration > Projector > Lens position

Level: Administrator, Service technician

### How to delete a Lens position

1. While in *Configuration > Projector > Lens position*, find and click on the lens position file you want to delete.

The lens position file is displayed in its expanded form with menu.

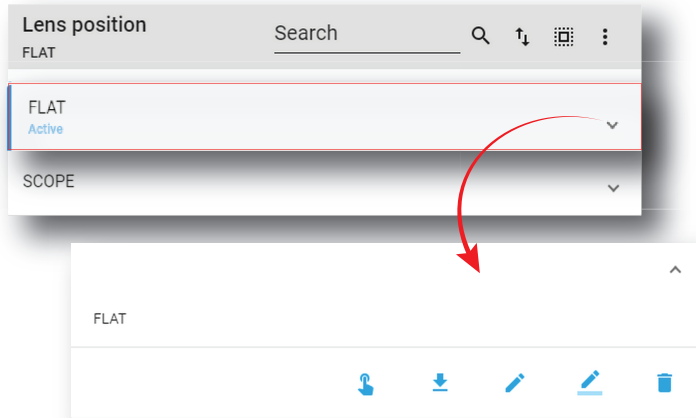



Image 7-77

- Click the **Delete** icon and confirm with **OK**. 
- The Lens position file is removed from the list.

## 7.4.10 Deleting several Lens position file

### Location & access

Menu: Configuration > Projector > Lens position

Level: Administrator, Service technician

### How to delete several Lens position files

- While in *Configuration > Projector > Lens position*, click **Select All** (reference 1) and use the check boxes (reference 2) located at right of the lens position files in order to select/deselect the files you want to delete.

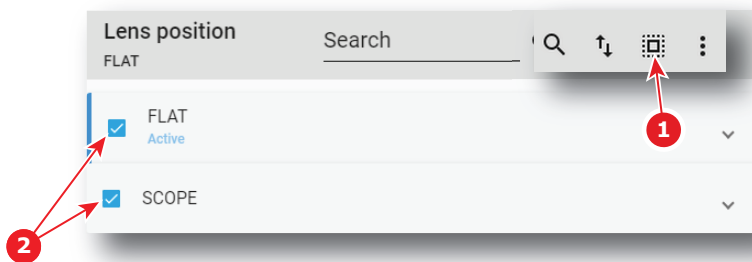

Image 7-78

- Click on the lens position general menu located on the top right of the list, then select **Delete** and confirm with **OK**.
- The lens position files selected are definitively removed from the list.

## 7.5 3D

### 7.5.1 About 3D file

#### Location & access

Menu: Configuration > Projector > 3D

Level: Administrator, Service technician

## Overview

This panel allows to manage 3D Configuration Files. These files contain all data needed to display 3D movies according 3D system. A batch of default files are installed on the projector during the initial setting with the clone package. Specific 3D files could be imported manually. 3D files must be adapted according to the 3D system used. Please refer to the 3D system manual to obtain correct settings.

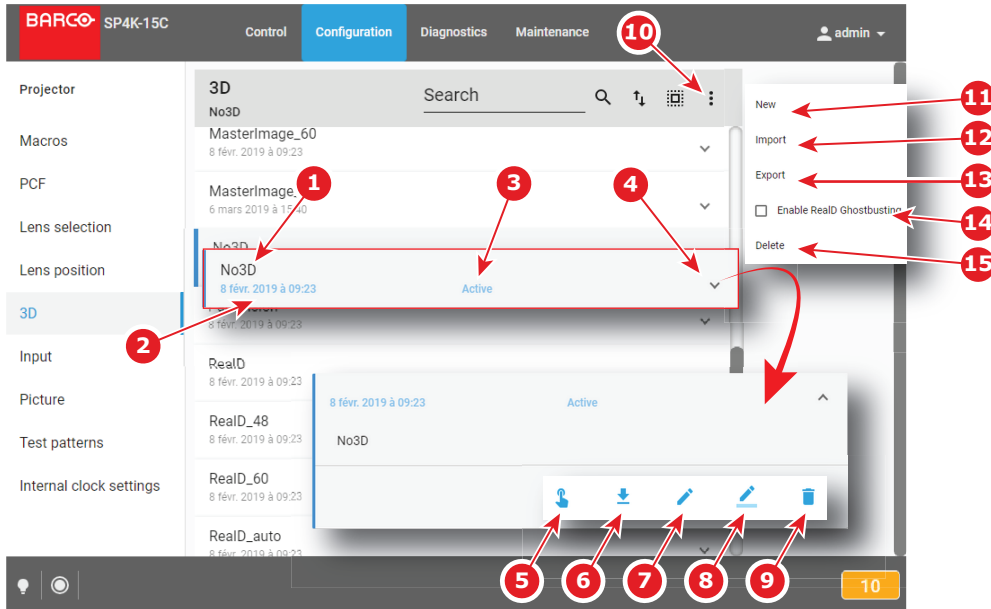

Image 7-79

Each 3D file displayed here has a *name* (reference 1). Creation date (reference 2) of the 3D file is displayed just under its name. When a 3D file is activated the status (reference 3) turns to *Active* and its name is noticed on top of the list.

Clicking on a 3D file (reference 4) in this list allows to show it in its expanded form and displays a contextual menu.

Following actions are available in this menu:

- **Activate** (reference 5) allows to activate the 3D file.
- **Export** (reference 6) creates a downloadable backup package.
- **Edit** (reference 7) allows to modify the 3D file.
- **Rename** (reference 8) allows to rename the 3D file.
- **Delete** (reference 9) allows to remove the 3D file from the list.

Clicking on menu (reference 10) displays the 3D file general menu.

Following actions are available in this menu:

- **New** (reference 11) allows to create 3D configuration files.
- **Import** (reference 12) allows to import 3D files.
- **Export** (reference 13) creates a downloadable backup package that contains all 3D files selected in the list.
- When the ICMP has a valid RealD license installed, switched on (or switched off) the check box **Enable RealD Ghostbusting** (reference 14) allows to activate (or deactivate) the *Reald Ghostbusting* algorithm. This algorithm allow to reduce the 3D crosstalk during play-out (also known as ghosting).
- **Delete** (reference 15) allows to remove several 3D files selected in the list.



Click on the name of the active file located on the top of the list to open it directly in edit mode.

## Management of 3D Files

Until now a 3D configuration file contained data needed to display a 3D movie with a specific frame rate. And it was necessary to repeat the creation process for each frame rate multiplication (24, 48, 60).



From version 1.2 or higher, it is still possible to work this way but this is no longer the normal process. The creation and management of 3D configuration files has been slightly modified.

Now, during creation process, it is no longer one file that is added to the 3D file list but four: a first file with the common parameters (`_auto`) and three additional files with the parameters dedicated to the different frame rates (24, 48, 60).

These files could be edited separately but system takes care to maintain consistency between files. By example, if user change L/R Input Reference of one file (e.g. `RealD_48`), that settings will be saved. But, while editing the `RealD_auto` file, a setting mismatch warning will be displayed on GUI (reference 1).

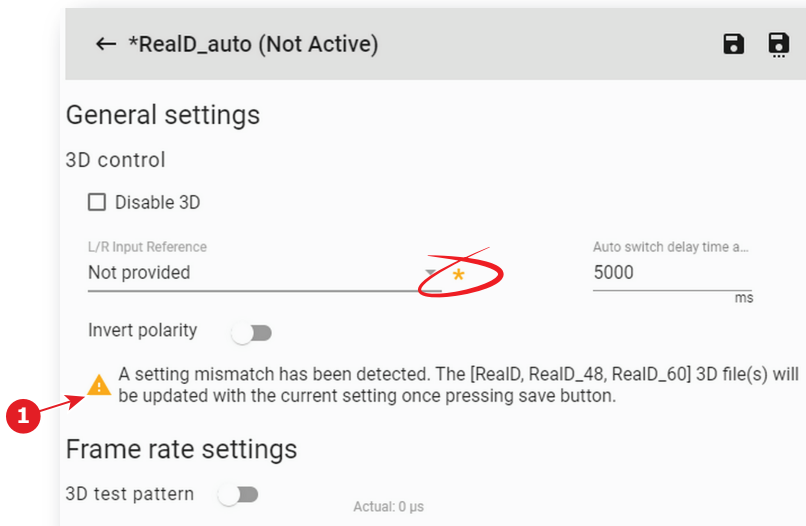

Image 7–80

When the user will save this file (`RealD_auto`), the settings mismatch will be solved by applying the same settings on all related files (`RealD_auto`, `RealD`, `RealD_48`, `RealD_60`).

## 7.5.2 Creating a 3D file

### Location & access

Menu: Configuration > Projector > 3D

Level: Administrator, Service technician

### How to create 3D file

1. While in *Configuration > Projector > 3D*, click on the 3D file general menu (reference 1) located on the top right of the list.

The menu is displayed.

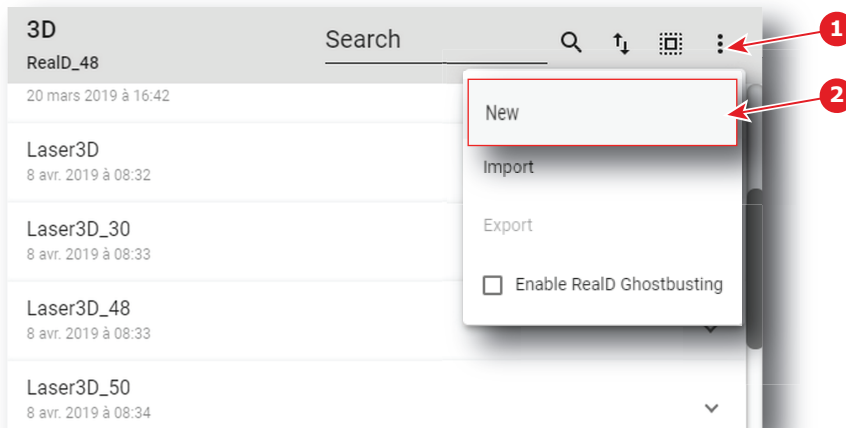

Image 7-81

2. Select **New** (reference 2) in the menu.  
3D file editor is displayed with a new (untitled) 3D file.

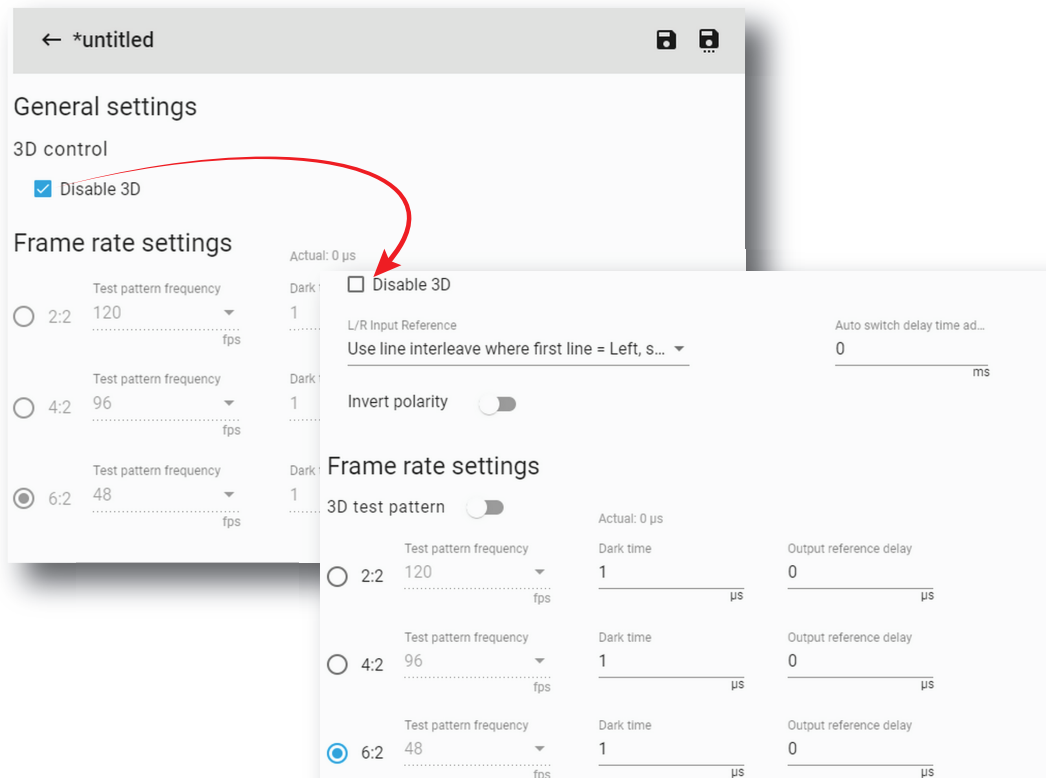

Image 7-82

3. Fill the 3D file parameters. From version 1.2 or higher, uncheck option *Disable 3D* allows to simultaneously create several 3D files with same name but dedicated to different frame rates (Auto, 2:2, 4:2, 6:2).

For more information about the *3D file editor*, see [“3D file editor”](#), page 131.

4. Click **Save As** (reference 3) to display the *Save As* window.

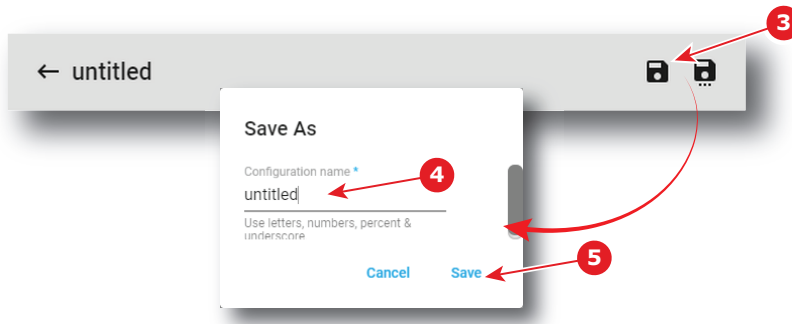

Image 7–83

5. Enter a name (reference 4).

- Note: List of files already available in the projector is displayed in this window. Directly click on this list allows you to reuse all or part of an already existing file name.

6. Click **save** (reference 5).

- Note: If the name enter in the previous step already exists, a warning is displayed. Click **Overwrite** to confirm and replace the existing the file.

From version 1.2 or higher, number of files created and added to the 3D files list is different if *Disable 3D* option is checked or not:

- if *Disable 3D* option is checked, one new file with name defined in step 5 is added to the 3D files list.
- if *Disable 3D* option is unchecked, 4 files are added to the 3D files list with names based on the name defined in step 5 and a suffix relative to different frame rates available (e.g. RealID, RealID\_48, RealID\_60 and RealID\_auto).

For more information about the *3D file* management, see “[About 3D file](#)”, page 127.

## 7.5.3 3D file editor

### About this chapter

This chapter contains all the necessary information to use 3D file editor, the Web Communicator page used to create or modify 3D files.

#### 7.5.3.1 3D Test pattern

##### What can be done?

With the 3D test pattern, it is possible to test the complete setup in combination with an external polarizer system, or active polarity glasses. The output frequency of the test pattern can be entered so that the simulation of the input signal is completely covered for the used polarizer system or polarity glasses.



Image 7–84 3D test pattern

- 1 Left eye (Green field with white L)
- 2 Right eye (Magenta field)

The left or the right eye pattern will be displayed alternatively. When e.g. the left pattern (indicated with L) is displayed, only the left eye may see this image. When it is not so, the setup is wrong and should be corrected.

### Entering the output frequency

1. While in *3D file editor*, check if *Disable 3D* option (reference 1) is unchecked in order to access the settings.

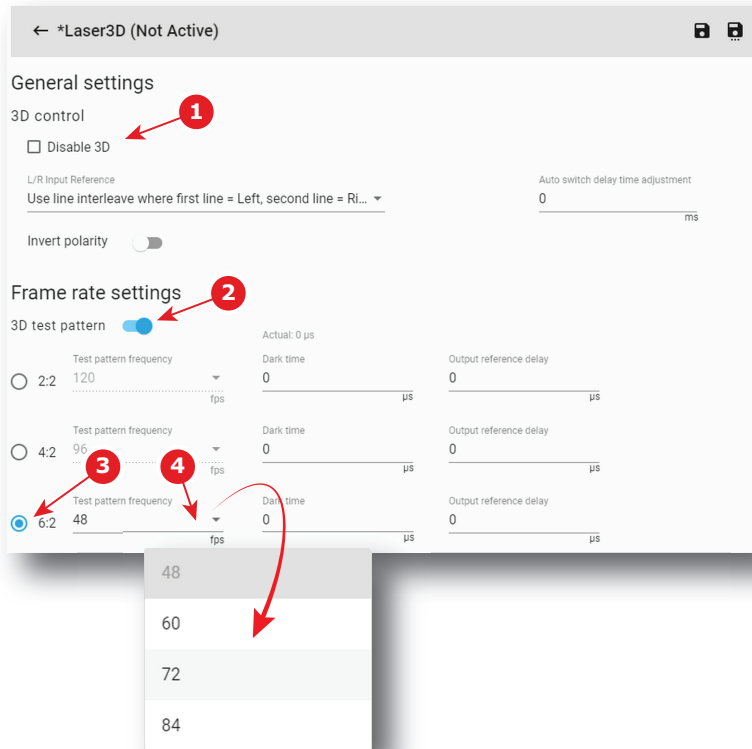

Image 7-85

2. Activate 3D test pattern (reference 2).
3. Select the playback frame rate (reference 3) for which the settings will be apply.
4. Select a new test pattern output frequency in drop down list (reference 4).
5. If necessary, repeat steps 3 and 4 at other playback frame rates.

### 7.5.3.2 3D control

#### L/R Input Reference

The Input Reference indicates which frame is Right and which frame is Left.

The following choices are possible:

Setting	Description
None Provided	no 3D L/R input reference provided
Use input reference - frame sequence mode (polarity = true)	Use Active data port assignment (for dual port sources) to determine 3D L/R input reference.
Use line interleave where first line = left, second line = right	Uses the default assignment for 3D L/R reference.

## How to adjust 3D control parameters

1. While in *3D file editor*, switch off **Disable 3D** (reference 1) to activate 3D control.

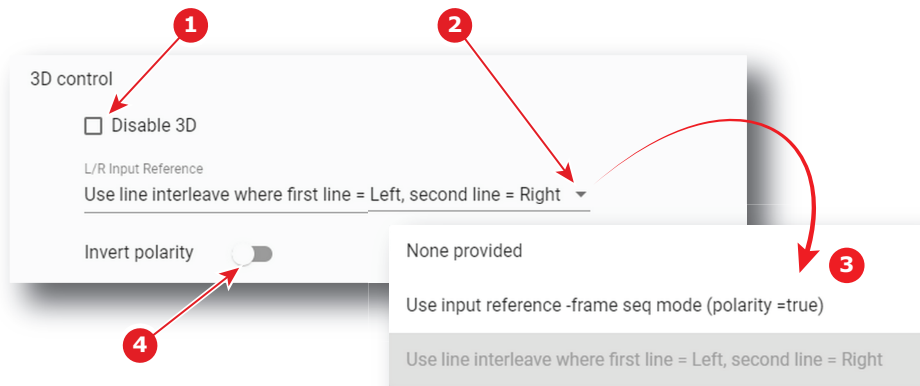

Image 7–86

2. Select the L/R Input Reference. Click on drop down list (reference 2) to display the menu (reference 3), then select the desired value.
3. Select switch on

### 7.5.3.3 Dark time adjustment

#### Dark Time Adjustment

Between switching the frames the image needs to be black the same time the external devices need to switch (external devices can be 3D Glasses, or polarizing filter).

For 3D applications, systems typically need a period of time where the image projected on the screen is black. This black or “dark time” is used to switch the mechanism that controls what a viewers left eye and right eye sees. This software command is used to adjust the projector dark time to meet the requirements of whatever switching mechanism is being used.

3D dark time adjustment will be disabled (set to 0) whenever 3D is disabled. With 3D enabled and 3D dark time adjustment disabled, the projector will be set to its default dark time of approximately 388  $\mu$ s. There is no dark time when 3D is disabled.

The system will have a minimum and maximum dark time that can be achieved. If the specified value is smaller than the system can provide, the dark time will be set to the systems minimum value, which will be reported as the actual dark time value. If the specified value is larger than the system can provide, the dark time will be set to the systems maximum value, which will be reported as the actual dark time value.

For 3D applications, systems typically need a period of time where the image projected on the screen is black. This black or “dark time” is used to switch the mechanism that controls what a viewers left eye and right eye sees. For most 3D applications, the system will provide an output reference signal that indicates whether left or right eye data is being displayed, as well as the start of dark time. This signal is the 3D L/R Output Reference.

#### How to adjust

1. While in *3D file editor*, check if *Disable 3D* option (reference 1) is unchecked in order to acceded the settings.

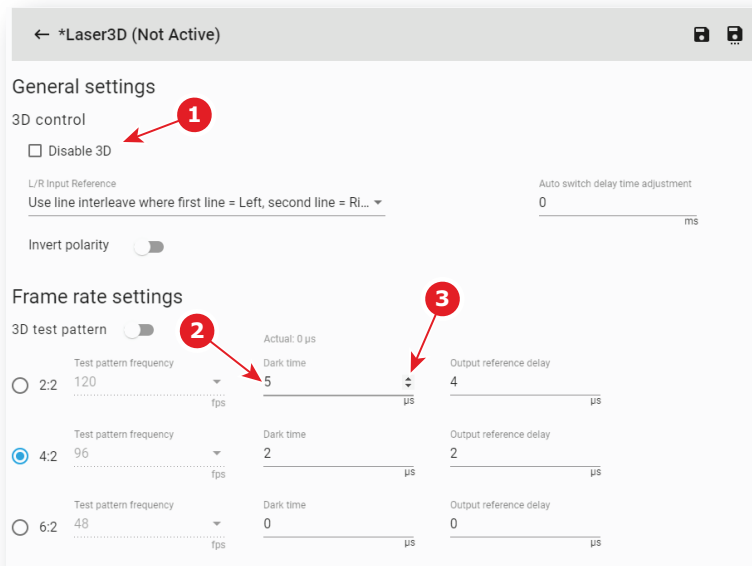

Image 7–87

2. Identify the playback frame rate (2:2, 4:2, 6:2) for which the settings will be apply, then enter a dark time adjustment value in  $\mu\text{s}$  with the keyboard (e.g. reference 2).  
or  
Use the plus button or minus button (reference 3) to adjust the value (+/- 1  $\mu\text{s}$ ).
3. If necessary, repeat previous step at other playback frame rates.

### 7.5.3.4 Output Reference Delay

#### Output Reference Delay

The output reference delay shifts the output reference signal. That results in the best 3D viewing with the least possible crosstalk between eyes.

Delay value from Delay – Time is added to the nominal timing between the displayed dark time and the 3D L/R Output Reference.

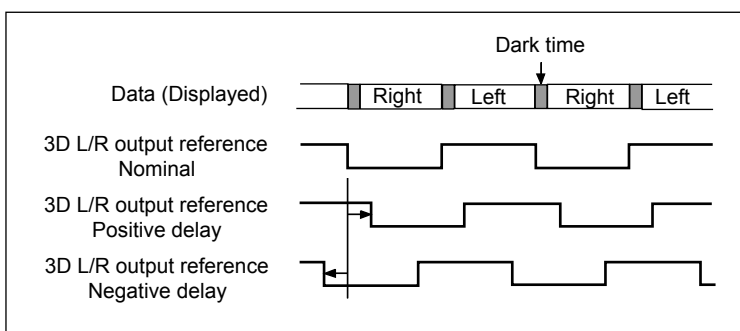

Image 7–88 Delay example for 3D L/R Output Reference



If you require corrective lenses to see a cinema screen clearly, be sure you have them available.

#### How to adjust the reference delay

1. Start the synchronization delay test clip related to playback frame rate for which the settings will be apply, or select appropriate 3D test pattern in *Control > Projector > Test Patterns* first.

- While in 3D file editor, check if *Disable 3D* option (reference 1) is unchecked in order to access the settings.

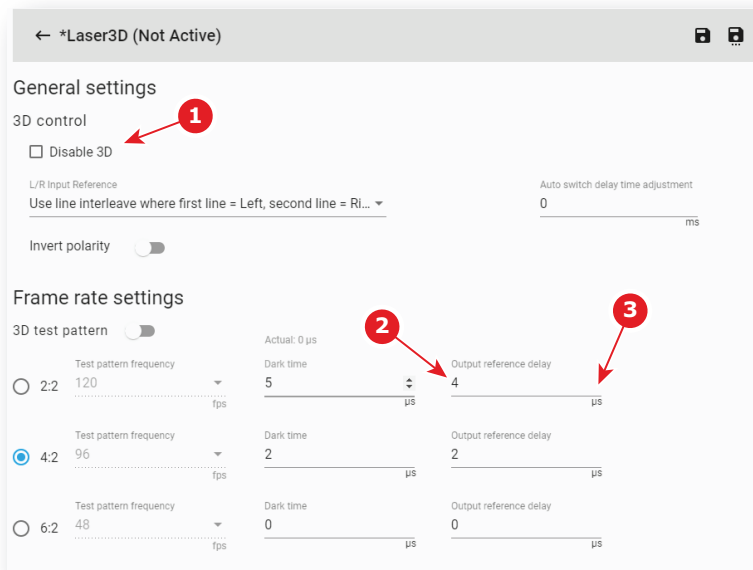



Image 7–89

- Put on the glasses and view the screen, covering or closing first one eye and then the other.

 **Note:** Do not adjust the reference delay value with both eyes open.

- Start e.g. the adjustment with the left eye,  
Enter a delay value in  $\mu\text{s}$  with the keyboard (reference 2).

or

use the plus button or minus button (reference 3) to adjust the delay (+/- 1  $\mu\text{s}$ ) until the white stripes disappear in the black column.

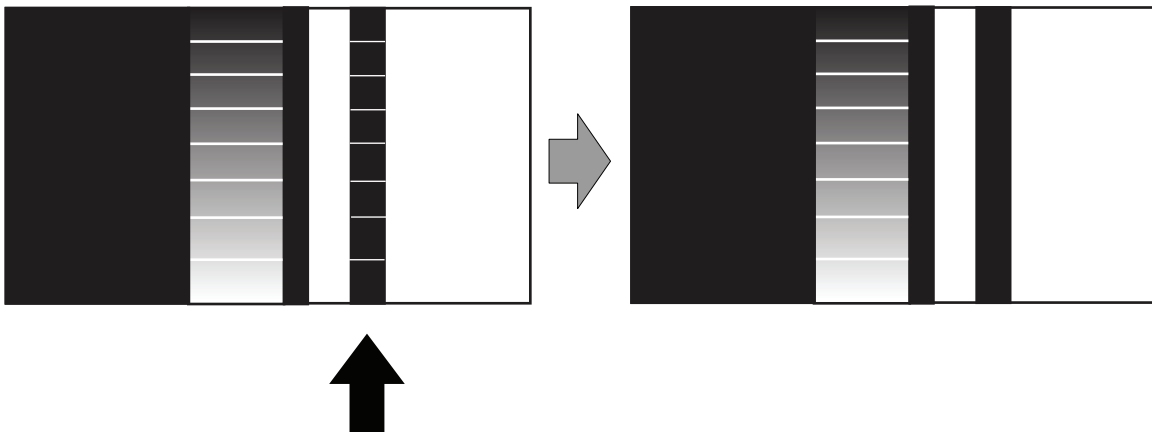

Image 7–90 Left eye delay test content

- Continue with the right eye and adjust the delay again.

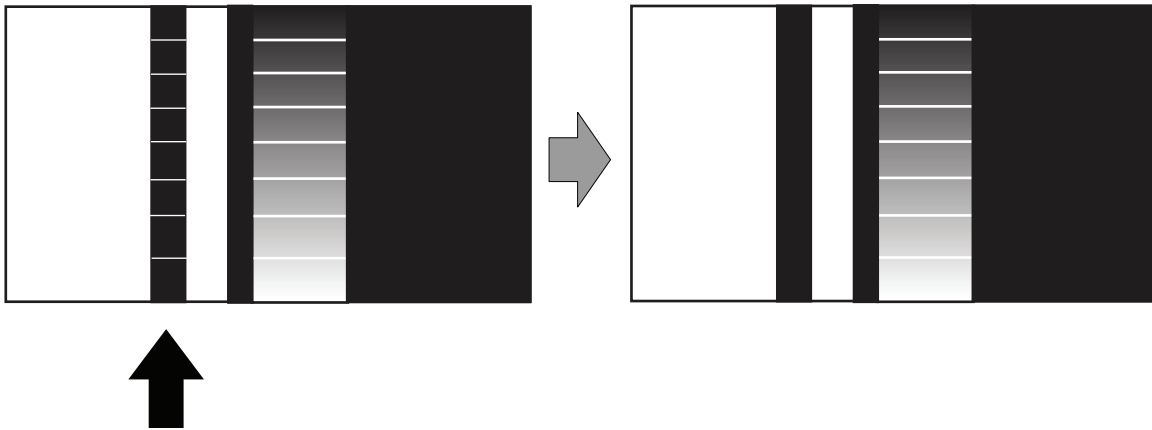

Image 7-91 Right eye delay test content

6. When the left and right eye image appear superimposed the Reference delay is not correctly optimized. Repeat the procedure.
7. If necessary, repeat all the procedure at other playback frame rates.

### 7.5.3.5 Auto switch delay time adjustment

#### Auto switch delay time

When playing a 3D contents, the ICMP and ICP-D can automatically detect the frame rate of the played content and configure the frame rate multiplier accordingly.

That feature simplifies the show creation by allowing the exhibitor to use a single macro whatever the frame rate of the content (additional macro to handle the content's aspect ratio differences are still needed).

This Auto adjustment can be activated by using the *name\_auto.3D* in the Macro.

When this file is activated, the ICMP or ICP-D will check the frame rate played and will activate 3d settings such as *Dark time adjustment* and *Output reference delay* contained in the other files such as *name\_24.3D*.

The selection of the file used will be based on the following table:

Frame Rate played (fps/eye)	3D file used by the Auto configuration ( <i>name_auto.3D</i> )	Frame Rate multiplier setting called
From 24 to 47	<i>name_24.3D</i> or <i>name.3D</i>	6:2
From 48 to 59	<i>name_48.3D</i>	4:2
From 60 to higher	<i>name_60.3D</i>	2:2

For 3D application, the system need typically a period of time to be synchronized with the playout. An additional parameter then available in web communicator in order to adjust that period of time; the *Auto switch delay time* adjustment. That setting will then delay the playout, by the amount of *ms* configured, if a change in the frame rate is detected between the previous and the next clip to be played.

#### How to adjust auto switch delay time

1. While in 3D file editor, check if *Disable 3D* option (reference 1) is unchecked in order to acceded the settings.



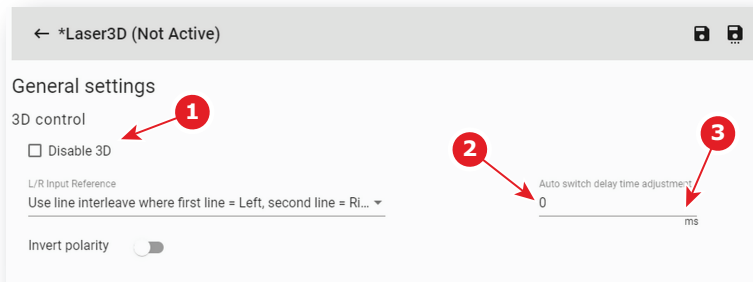

Image 7-92

2. Enter delay value in ms with the keyboard (reference 2).

or

Use the plus button or minus button (reference 3) to adjust the value (+/- 1 ms).

## 7.5.4 Editing a 3D file

### Location & access

Menu: Configuration > Projector > 3D

Level: Administrator, Service technician

### How to edit

1. While in *Configuration > Projector > 3D*, find and click on the 3D file you want to edit.  
The 3D file is displayed in its expanded form with menu.

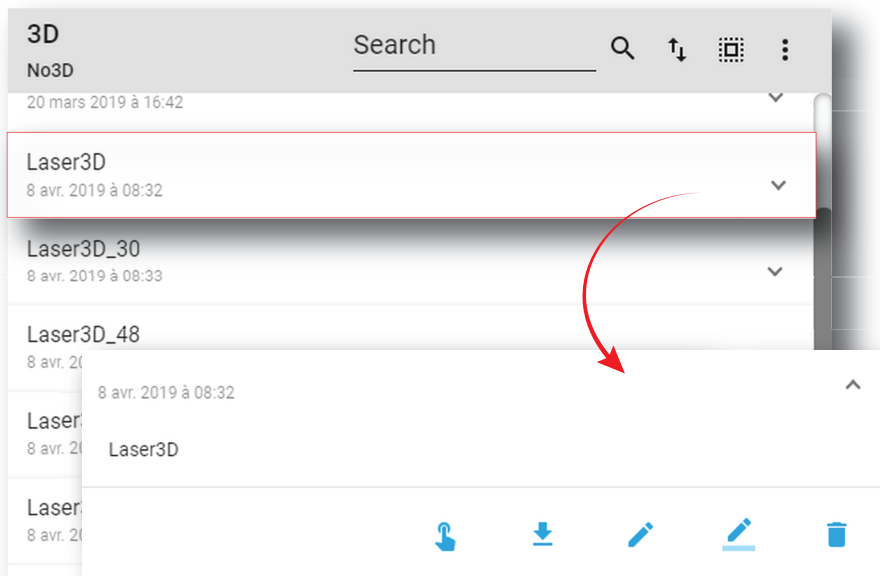

Image 7-93

2. Click the **Edit** icon in the menu. 

The 3D file is displayed in *3D file editor*.

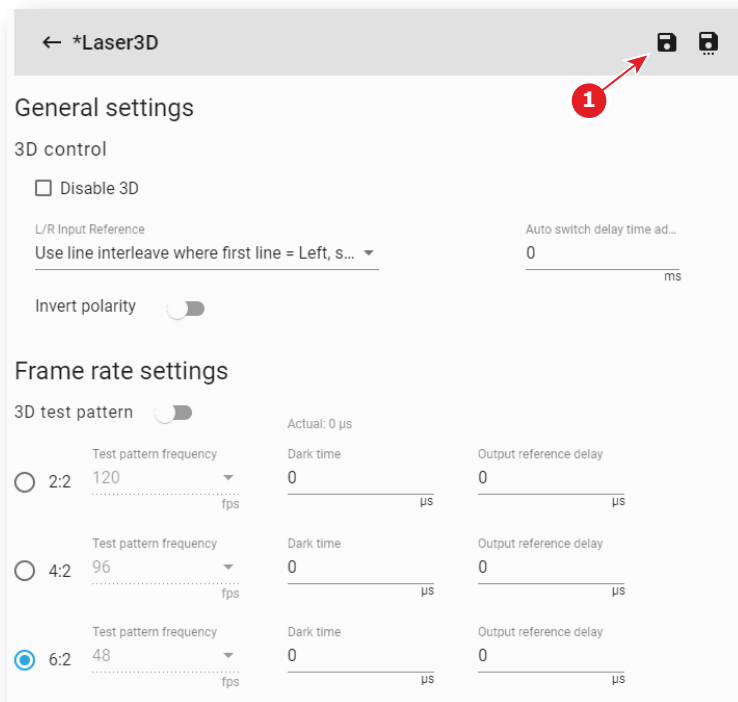

Image 7-94

3. Modify the 3D file parameters. For more information about the *3D file editor*, see [“3D file editor”](#), page 131.
4. Click the **Save** icon (reference 1).

## 7.5.5 Activating a 3D file

### Location & access

Menu: Configuration > Projector > 3D

Level: Administrator, Service technician

### What is possible

Usually a 3D file is activated via a macro but it is possible to directly activate a 3D file by clicking on **Activate** in the contextual menu.

### How to activate

1. While in *Configuration > Projector > 3D*, find and click on the 3D file you want to activate.  
The 3D file is displayed in its expanded form with menu.

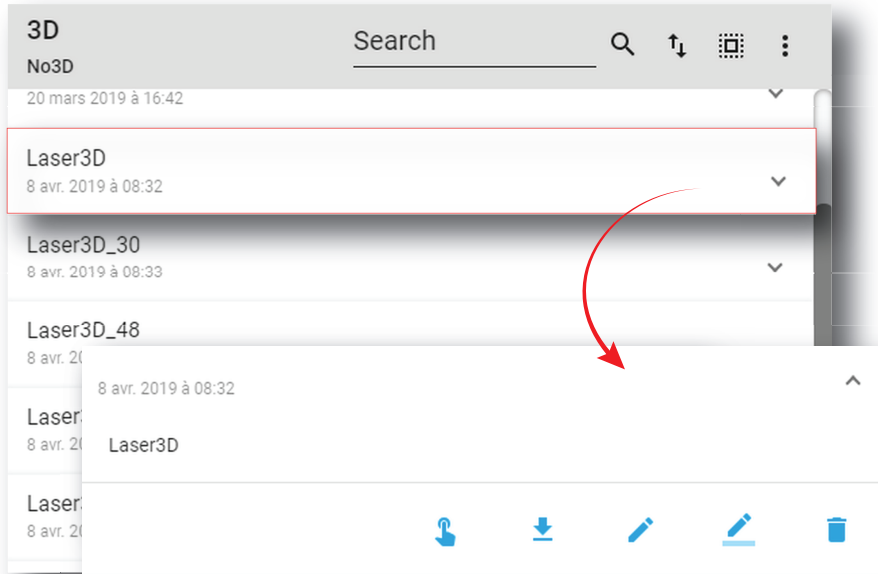

Image 7-95

- Click **Activate** in the menu.



The new configuration is applied and visible on top of the list. The status of the 3D file also turns to *Active*.

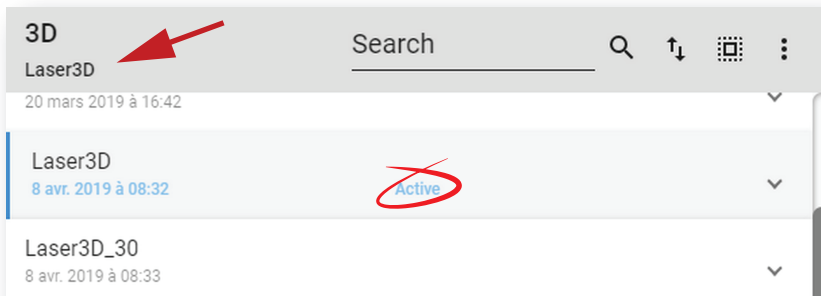

Image 7-96



Click on the name of the active file located on the top of the list to open it directly in edit mode.

## 7.5.6 Renaming a 3D file

### How to rename

- While in *Configuration > Projector > 3D*, find and click on the 3D file you want to rename.  
The 3D file is displayed in its expanded form with menu.

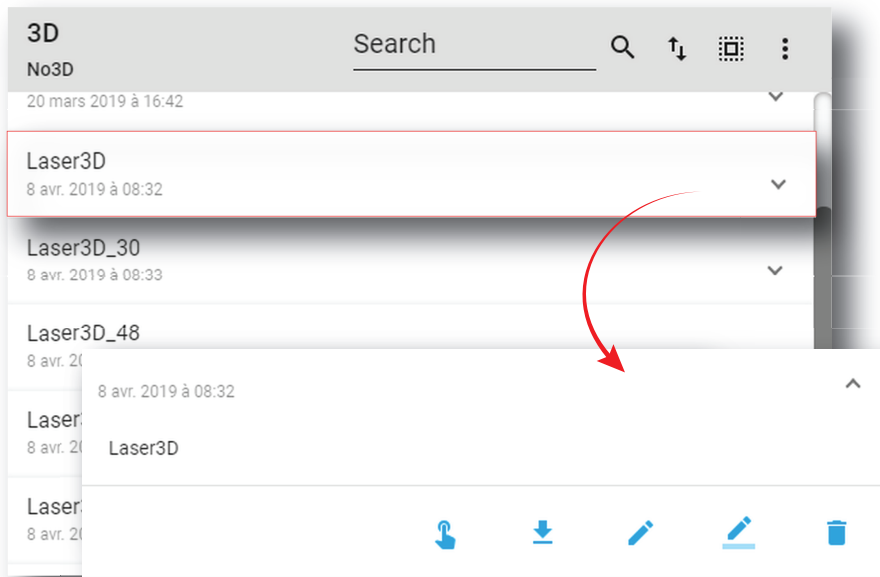



Image 7-97

2. Click the **Rename** icon.  The *Rename* window is prompted.

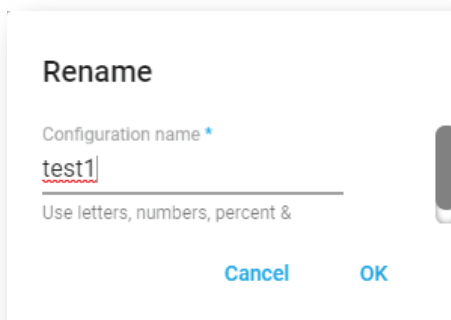

Image 7-98

3. Enter a new name and confirm with **OK**.

## 7.5.7 Importing a 3D file

### Location & access

Menu: Configuration > Projector > 3D

Level: Administrator, Service technician

### How to import a 3D file

1. While in *Configuration > Projector > 3D*,+ click on the 3D file general menu (reference 1) located on the top right of the list.  
The menu is displayed.

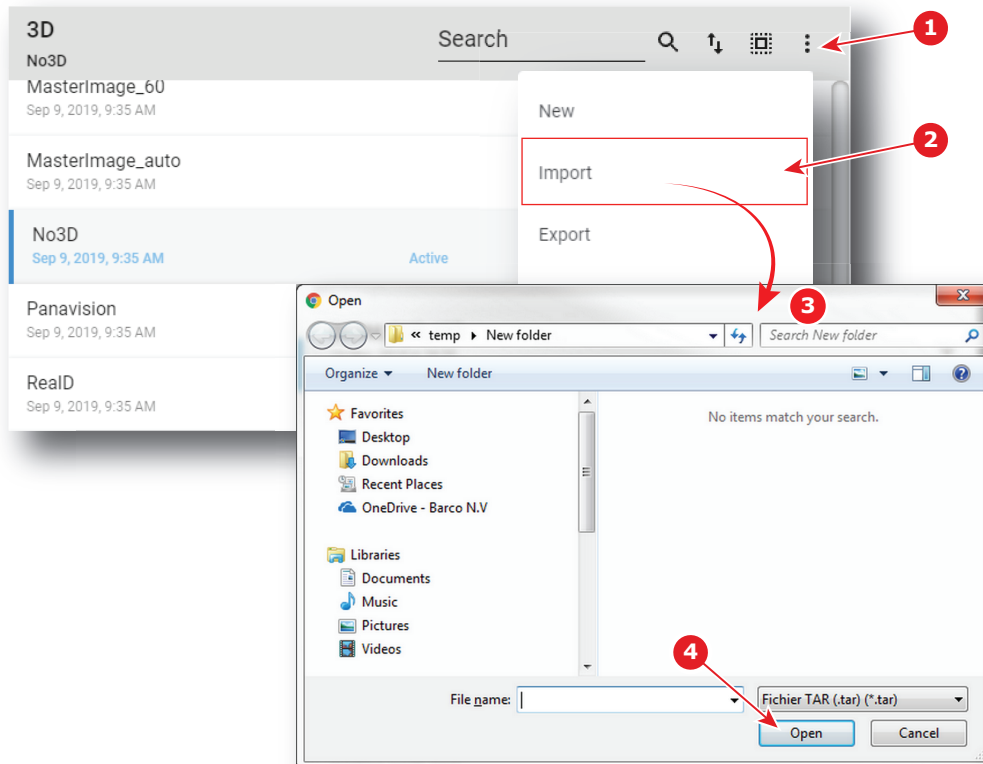

Image 7-99

2. Select **Import** (reference 2) in the menu.  
Open window (reference 3) is displayed
3. Locate and select the 3D file.
4. Click **Open** (reference 4).  
3D file is imported and added to the 3D files list.

## 7.5.8 Exporting a 3D file

### Location & access

Menu: Configuration > Projector > 3D

Level: Administrator, Service technician

### How to export a 3D file

1. While in *Configuration > Projector > 3D*, find and click on the 3D file you want to export.  
The 3D file is displayed in its expanded form with menu.

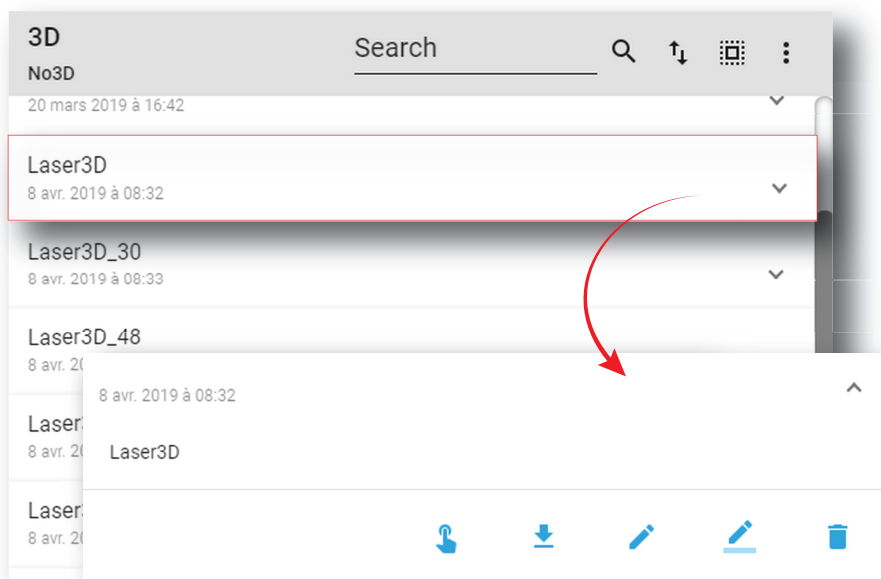

Image 7-100

2. Click the **Export** icon in the menu.



The *Download package* window is displayed during backup package creation.

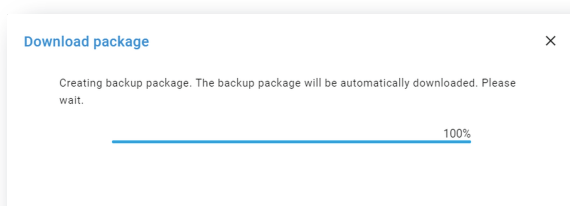

Image 7-101

3. When the backup package is created it is automatically copied in the *Downloads* directory of your computer (e.g. *3D-backup-SP4K-15C-2590153431-2019-04-11T142930Z.tar*).

## 7.5.9 Exporting several 3D files in a backup package

### What is possible

Several 3D files could be exported at once in a backup package.

### Location & access

Menu: Configuration > Projector > 3D

Level: Administrator, Service technician

### How to create and export backup package of 3D files

1. While in *Configuration > Projector > 3D*, click **Select All** (reference 1) and use the check boxes (reference 2) located at right of the 3D files in order to select/deselect the files you want to export.

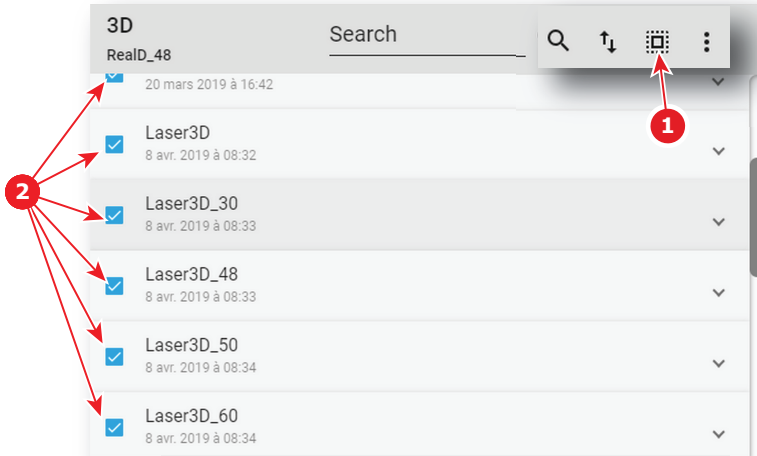

Image 7-102

2. Click on the menu icon (reference 3) and select **Export**.

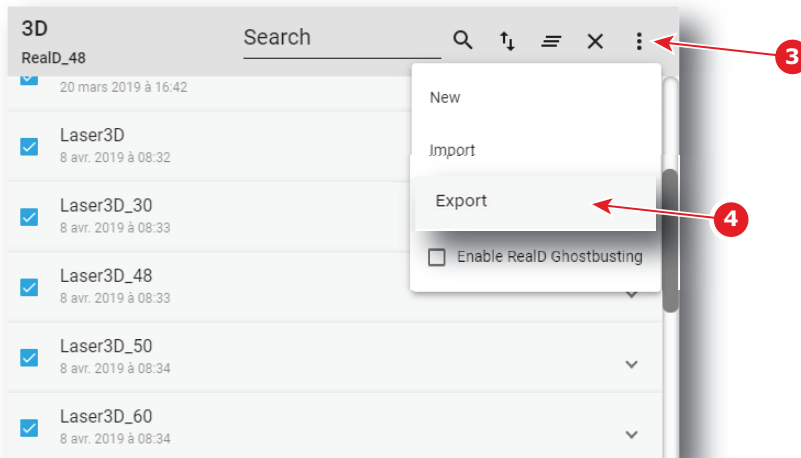

Image 7-103

The *Download package* window is displayed during backup package creation.

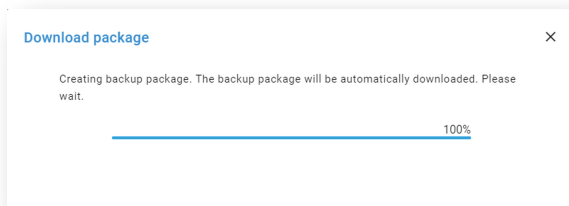

Image 7-104

3. When backup package is created, it is automatically copied in the *Downloads* directory of your computer (e.g. *3D-backup-SP4K-15C-2590153431-2019-04-11T142930Z.tar*).

## 7.5.10 Delete a 3D file

### Location & access

Menu: Configuration > Projector > 3D

Level: Administrator, Service technician

## How to delete

1. While in *Configuration > Projector > 3D*, find and click on the 3D file you want to delete.  
The 3D file is displayed in its expanded form with menu.

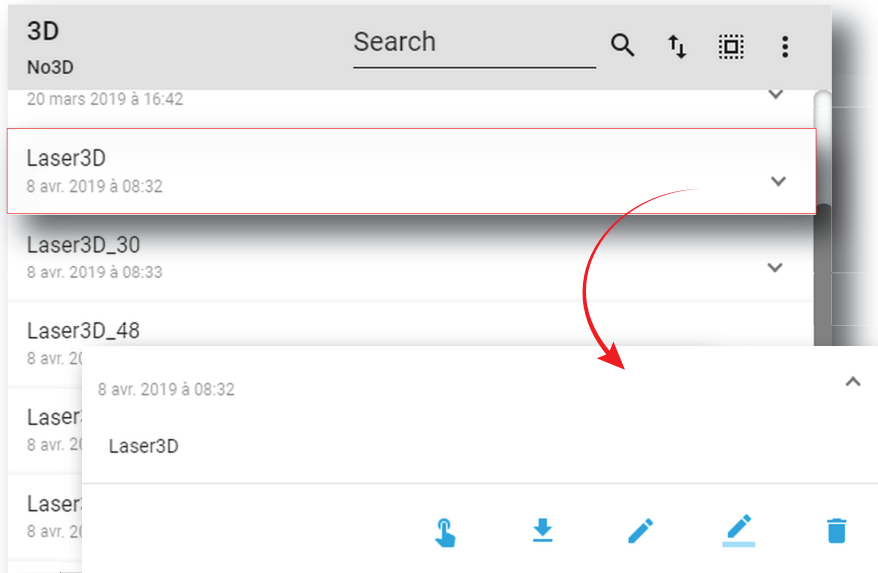

Image 7-105

2. Click the **Delete** icon and confirm with OK 

The 3D file is removed from the list.

## 7.5.11 Deleting several 3D files

### Location & access

Menu: Configuration > Projector > 3D

Level: Administrator, Service technician

### How to delete several 3D files

1. While in *Configuration > Projector > 3D*, click **Select All** (reference 1) and use the check boxes (reference 2) located at right of the 3D files in order to select/deselect the files you want to delete.



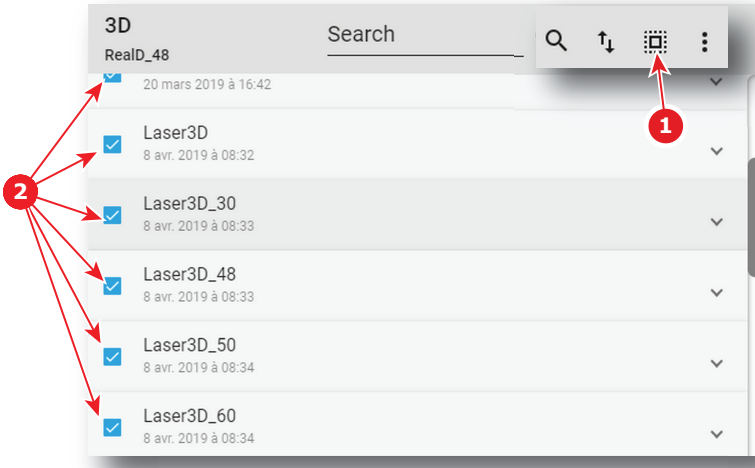

Image 7–106

2. Click on the 3D file general menu located on the top right of the list, then select **Delete** and confirm with **OK**.

The 3D files selected are definitively removed from the list.

## 7.6 Input

### 7.6.1 About Input file

#### Location & access

Menu: Configuration > Projector > Input

Level: Administrator, Service technician

#### Overview

This panel allows to manage Input configuration files. These files contain all data needed to activate input according to connected device that provide the video signal (e. g. ICMP media player, Blu-ray HDMI player ... ). A batch of default files are installed on the projector during the initial setting with the clone package. Specific input files could be imported manually. Input files must be adapted according to the connected device.

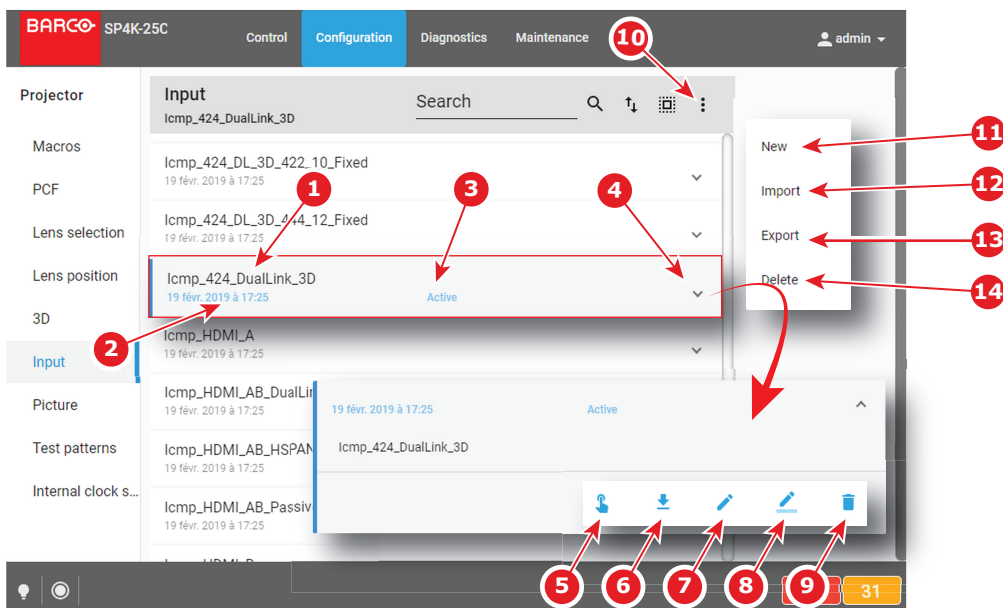

Image 7–107

Each input file displayed here has a *name* (reference 1). Creation date (reference 2) of the file is displayed just under its name. When a input file is activated the status (reference 3) turns to *Active* and its name is noticed on top of the list.

Clicking on a input file (reference 4) in this list allows to show it in its expanded form and displays a contextual menu.

Following actions are available in this menu:

- **Activate** (reference 5) allows to activate the input file.
- **Export** (reference 6) creates a downloadable backup package.
- **Edit** (reference 7) allows to modify the input file.
- **Rename** (reference 8) allows to rename the input file.
- **Delete** (reference 9) allows to remove the input file from the list.

Clicking on menu (reference 10) displays the input file general menu.

Following actions are available in this menu:

- **New** (reference 11) allows to create a new input file.
- **Import** (reference 12) allows to import an input file.
- **Export** (reference 13) creates a downloadable backup package that contains all input files selected in the list.
- **Delete** (reference 14) allows to remove several input files selected in the list.



Click on the name of the active file located on the top of the list to open it directly in edit mode.

## 7.6.2 Creating an input file

### Location & access

Menu: Configuration > Projector > Input

Level: Administrator, Service technician

### How to create Input file

1. While in *Configuration > Projector > Input*, click on the input file general menu (reference 1) located on the top right of the list.

The menu is displayed.

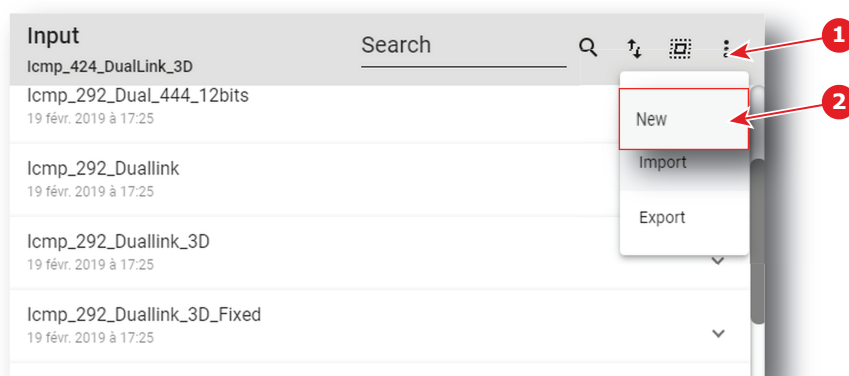

Image 7-108

2. Select **New** (reference 2) in the menu.

*Input file editor* (reference 3) is displayed with a new (untitled) input file.

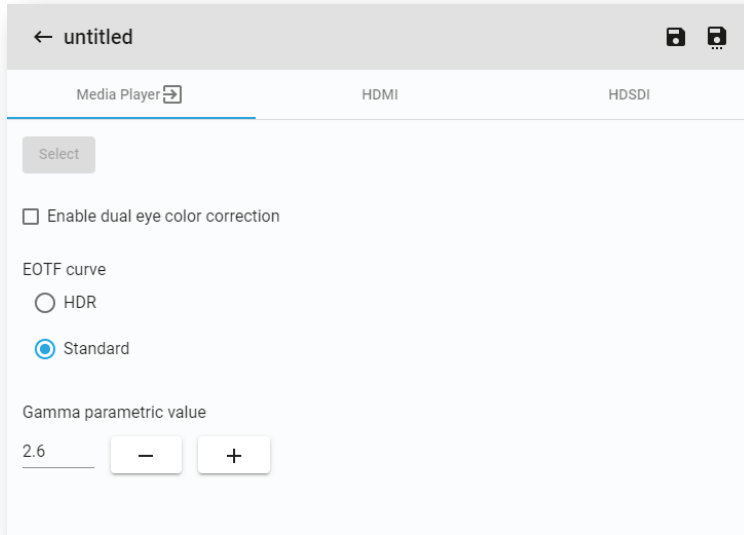

Image 7–109

3. Fill the input file parameters. For more information about the *input file editor*, see [“Input file editor”](#), page 147.
4. Click **Save As** (reference 3) to display the *Save As* window.

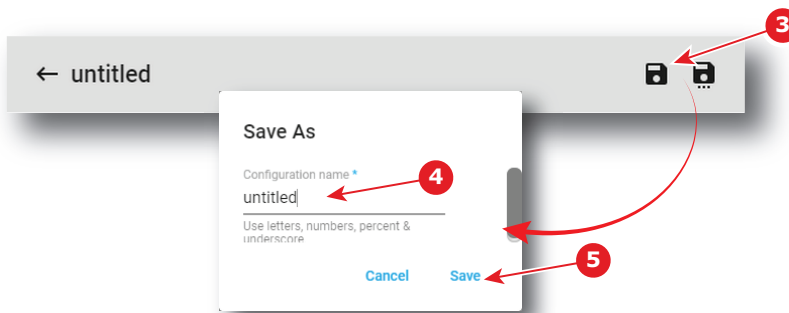



Image 7–110

5. Enter a name (reference 4).
  -  **Note:** List of files already available in the projector is displayed in this window. Directly click on this list allows you to reuse all or part of an already existing file name.
6. Click **save** (reference 5).
  -  **Note:** If the name enter in the previous step already exists, a warning is displayed. Click **Overwrite** to confirm and replace the existing the file.

New 3D file is added to the 3D files list.

## 7.6.3 Input file editor

### About this chapter

This chapter contains all the necessary information to use input file editor, the Web Communicator page used to create or modify input files.

#### 7.6.3.1 HDS DI (3G-S DI) for ICMP

#### How to adjust HDS DI (3G-S DI) parameters for ICMP

1. While in *input file editor*, click **HDS DI** (reference 1).

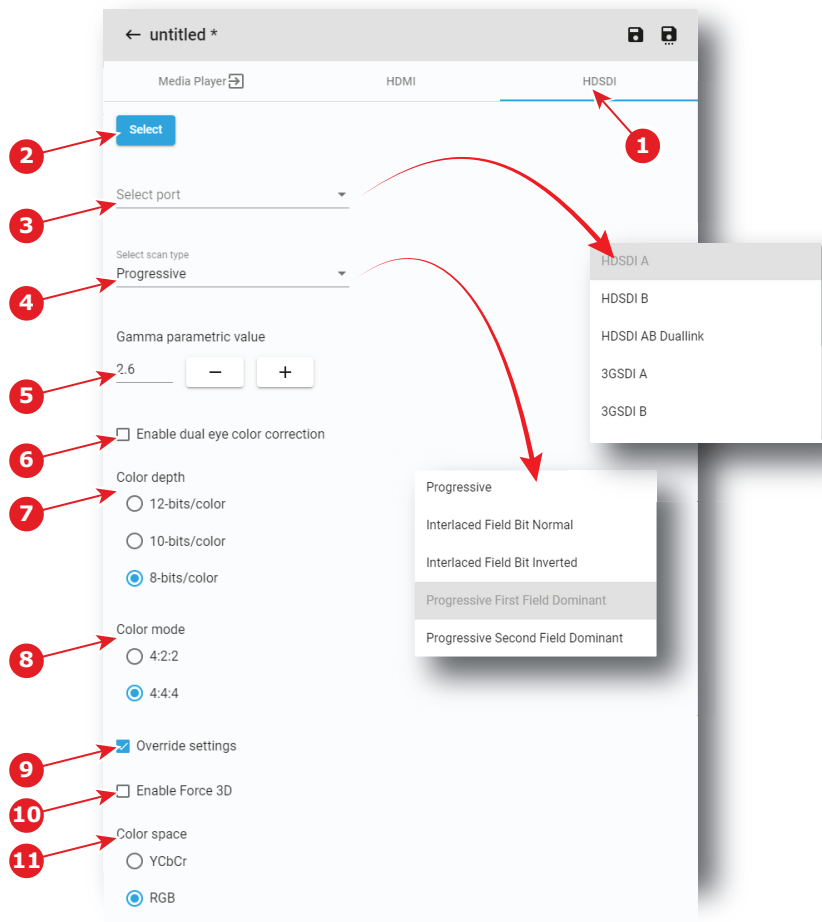

Image 7–111

2. If not already done, click **Select** (reference 2) to specify that HD-SDI is right now the source format for this file.

3. Select the *port* in the drop down list (reference 3).

The following ports are available:

- HDSDI A
- HDSDI B
- HDSDI AB Duallink
- 3GSDI A
- 3GSDI B
- 3GSDI AB Hspan
- 3GSDI A LevelB
- 3GSDI B LevelB
- 3GSDI A LevelB Dualstream
- 3GSDI B LevelB Dualstream

To obtain more details concerning the HD-SDI ports see [“ICMP-X SDI specifications”, page 365](#).

4. Select the *scan type* in the drop down list (reference 4).

The available list of scan type depends on the port selected in the previous step. To obtain more details concerning the HD-SDI ports see [“ICMP-X SDI specifications”, page 365](#).

5. Use the **plus** button or **minus** button to adjust *Gamma parametric value* depending on the source.

6. Select the desired color correction.

The following corrections are possible:

- **Enable dual eye color correction** (reference 6) must be not checked to chose “single eye” color correction.

- **Enable dual eye color correction** (reference 6) must be checked to chose “dual eye” color correction (separate eyes).

7. Define *color depth* (reference 7) and *color mode* (reference 8). These values must be adapted depending the specifications of the selected signal.

To obtain more details concerning the HD-SDI ports see “[ICMP-X SDI specifications](#)”, page 365.

8. Depending on your selection, detailed settings can be set.

When **Override settings** (reference 9) are not overruled (not checked), *Color Space* and *3D* are automatically set with the info given in the Info Frames inside the HD-SDI signal.

When **Override settings** (reference 9) are checked,

- *Color Space* (reference 11) can be set between RGB or YCbCr.
- Force 3D can be enabled or disabled (reference 10).

### 7.6.3.2 HDMI

#### How to adjust HDMI parameters

1. While in *input file editor*, click **HDMI** (reference 1).

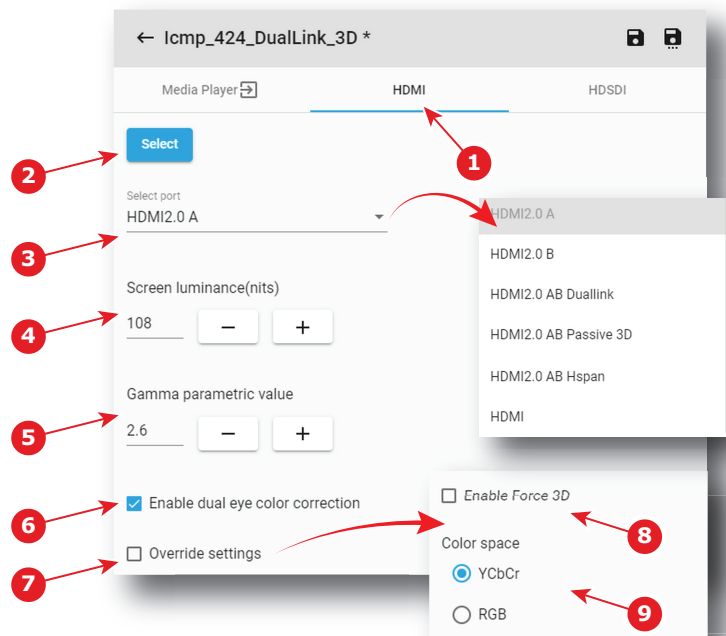

Image 7–112

2. If not already done, click **Select** (reference 2) to specify that HDMI is right now the source format select for this file.

3. Select the *port* in the drop down list (reference 3).

The following ports are available:

- HDMI2.0 A
- HDMI2.0 B
- HDMI2.0 AB Duallink
- HDMI2.0 AB Passive 3D
- HDMI2.0 AB Hspan
- HDMI

To obtain more details concerning the HDMI ports see “[ICMP-X HDMI 2.0 specifications](#)”, page 368.

4. Use the **plus** button or **minus** button to adjust *Screen luminance(nits)* (reference 4) depending on the source.

5. Use the **plus** button or **minus** button to adjust *Gamma parametric value* (reference 5) depending on the source.

6. Select the desired color correction.

The following corrections are possible:

- **Enable dual eye color correction** (reference 6) must be not checked to chose “single eye” color correction.
- **Enable dual eye color correction** (reference 6) must be checked to chose “dual eye” color correction (separate eyes).

7. Depending on your selection, detailed settings can be set.

When **Override settings** (reference 7) are not overruled (not checked), *Color Space* and *3D* are automatically set with the info given in the Info Frames inside the HDMI signal.

When **Override settings** (reference 7) are checked,

- *Color Space* (reference 9) can be set between RGB or YCbCr.
- Force 3D can be enabled or disabled (reference 8).

### 7.6.3.3 Media player

#### How to adjust media player parameters

1. While in *input file editor*, click **Media Player** (reference 1).

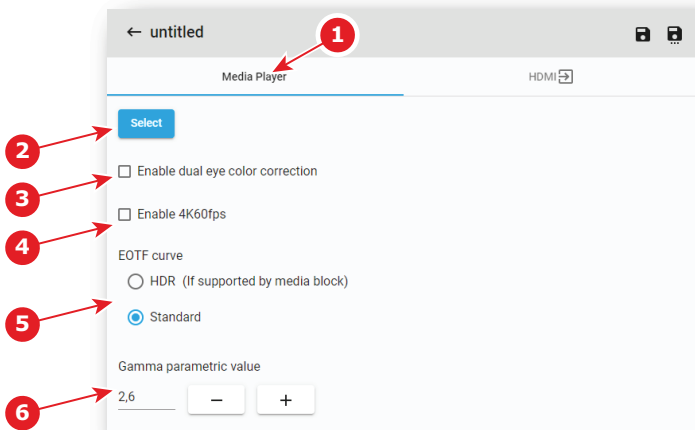

Image 7–113

2. If not already done, click **Select** (reference 2) to specify the *Media Player* is the desired source format chosen for this file.

3. Select the desired color correction.

The following corrections are possible:

- **Enable dual eye color correction** (reference 3) should be not checked to chose “single eye” color correction.
- **Enable dual eye color correction** (reference 3) should be checked to chose “dual eye” color correction (separate eyes).

4. If the Media player is an ICP-D associated with a Dolby IMB, it is possible to activate the 4K60fps mode:

- **Enable 4K60fps** (reference 4) should be not checked to choose not to enable 4K60fps mode.
- **Enable 4K60fps** (reference 4) should be checked to chose to enable the 4K60fps mode.

 *Note:* This option is only available on 4K projectors, not on 2K projectors.

5. Select EOTF (Electro-Optical Transfer Function) curve (reference 5).

The following choices are possible:

- **HDR** should be checked to chose “High Dynamic Range” content.

- **Standard** should be checked to chose standard content.

6. Use the **plus** button or **minus** button to adjust *Gamma parametric value* (reference 6) depending on the source.

## 7.6.4 Editing an input file

### Location & access

Menu: Configuration > Projector > Input

Level: Administrator, Service technician

### How to edit

1. While in *Configuration > Projector > Input*, find and click on the input file you want to edit.

The input file is displayed in its expanded form with menu.

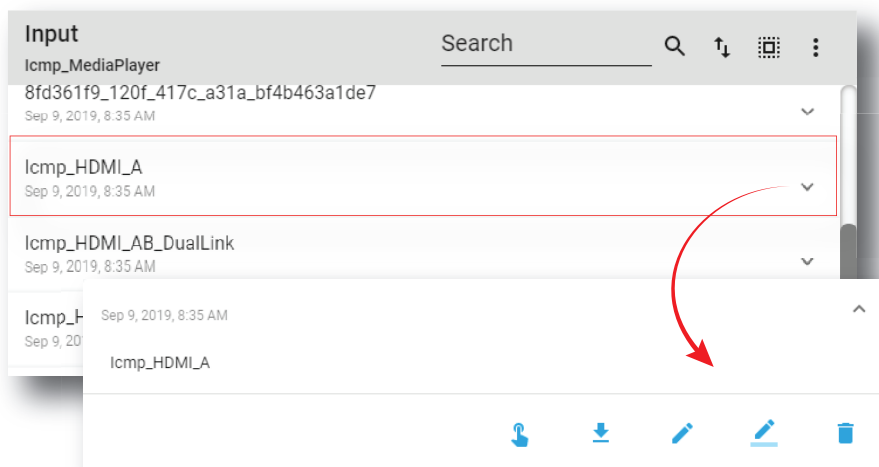

Image 7–114

2. Click **Edit** in the menu. 

The input file is displayed in *input file editor*.

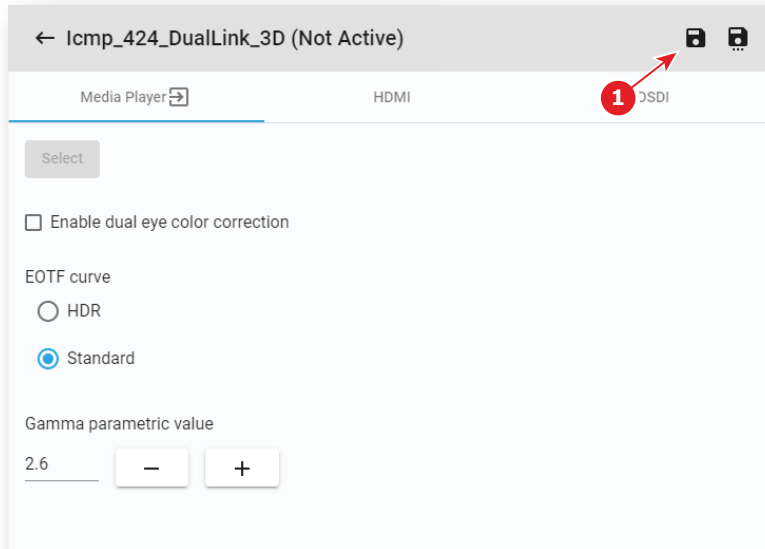

Image 7-115

3. Modify the input file parameters. For more information about the *input file editor*, see [“Input file editor”, page 147](#).
4. Click **Save** (reference 1).

## 7.6.5 Activating an input file

### Location & access

Menu: Configuration > Projector > Input

Level: Administrator, Service technician

### What is possible

Usually a Input file is activated via a macro but it is possible to directly activate a 3D file by clicking on **Activate** in the contextual menu.

### How to activate

1. While in *Configuration > Projector > Input*, find and click on the input file you want to activate.  
The input file is displayed in its expanded form with menu.



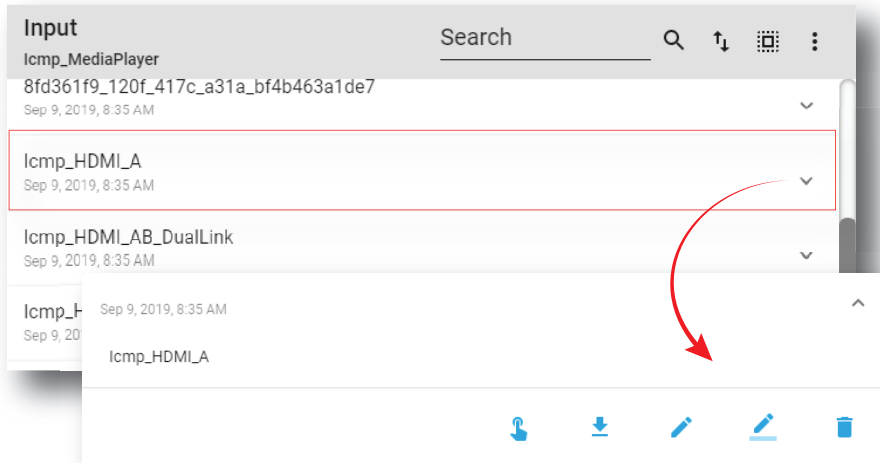

Image 7–116

2. Click **Activate** in the menu. 

The new configuration is applied. Status of the input file turns to *Active* and its name is noticed on top of the list.

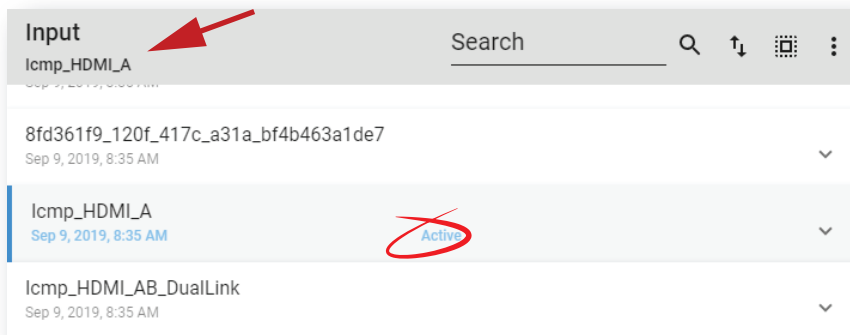



Image 7–117

 Click on the name of the active file located on the top of the list to open it directly in edit mode.

## 7.6.6 Renaming input file

### Location & access

Menu: Configuration > Projector > Input

Level: Administrator, Service technician

### How to rename

1. While in *Configuration > Projector > Input*, find and click on the input file you want to rename.  
The input file is displayed in its expanded form with menu.

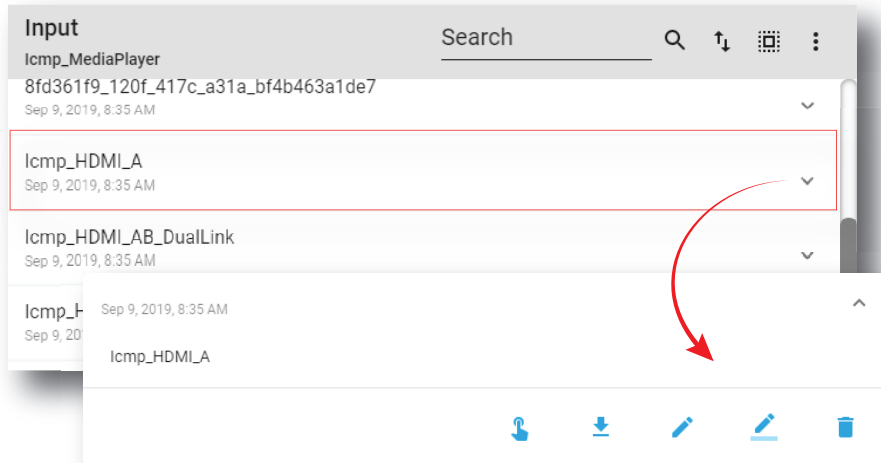



Image 7-118

2. Click **Rename** in the menu.   
*Rename* window is displayed.

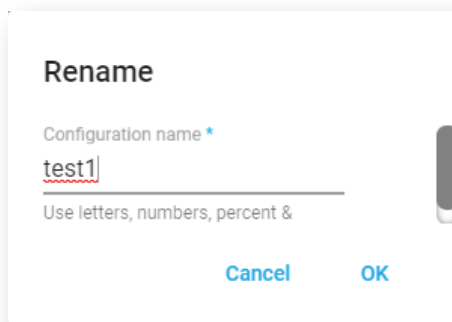

Image 7-119

3. Enter a new name and click **OK**.

## 7.6.7 Importing an input file

### Location & access

Menu: Configuration > Projector > Input

Level: Administrator, Service technician

### How to import a Input file

1. While in *Configuration > Projector > Input*, click on the input file general menu (reference 1) located on the top right of the list.

The menu is displayed.

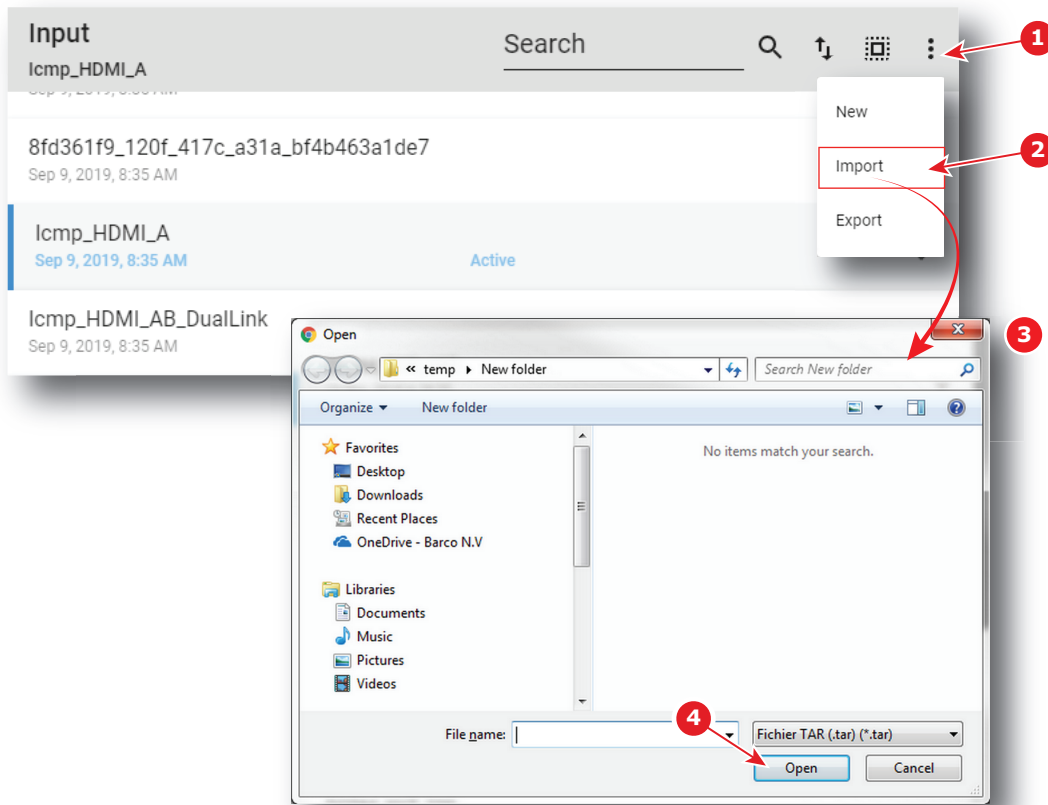

Image 7–120

2. Select **Import** (reference 2) in the menu.  
Open window (reference 3) is displayed
3. Locate and select the Input file.
4. Click **Open** (reference 4).  
The input file is imported and added to the files list.

## 7.6.8 Exporting an input file

### Location & access

Menu: Configuration > Projector > Input

Level: Administrator, Service technician

### How to export an Input file

1. While in *Configuration > Projector > Input*, find and click on the Input file you want to export.  
The input file is displayed in its expanded form with menu.

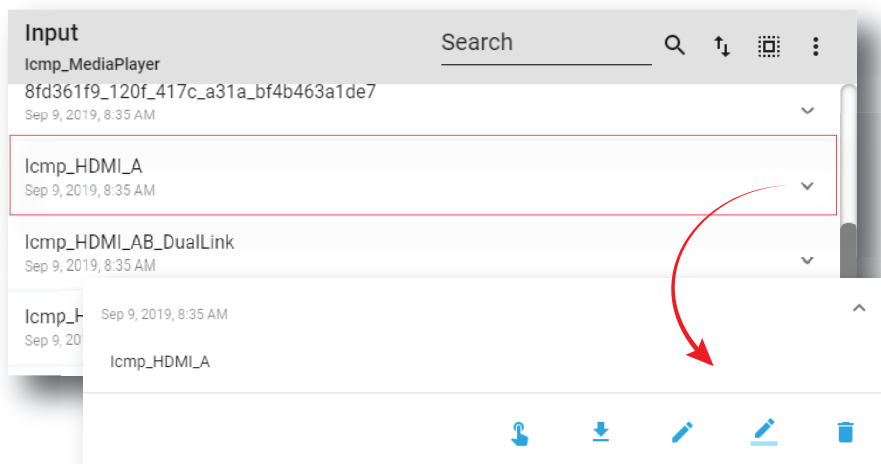

Image 7-121

2. Click **Export** in the menu. 

*Download package* window is displayed during backup package creation.

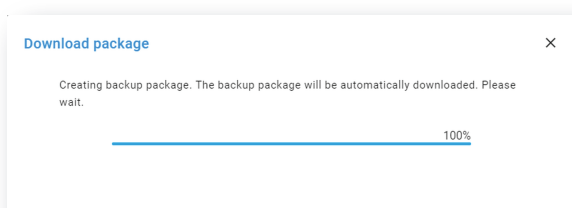

Image 7-122

3. When backup package is created, it is automatically copied in the *Downloads* directory of your computer (e.g. *INPUT-backup-SP4K-15C-2590153431-2019-04-13T104028Z.tar*).

## 7.6.9 Exporting several input files in a backup package

### What is possible

Several input files could be exported at once in a backup package.

### Location & access

Menu: Configuration > Projector > Input

Level: Administrator, Service technician

### How to create and export backup package of input files

1. While in *Configuration > Projector > Input*, click **Select All** (reference 1) and use the check boxes (reference 2) located at right of the input files in order to select/deselect the files you want to export.

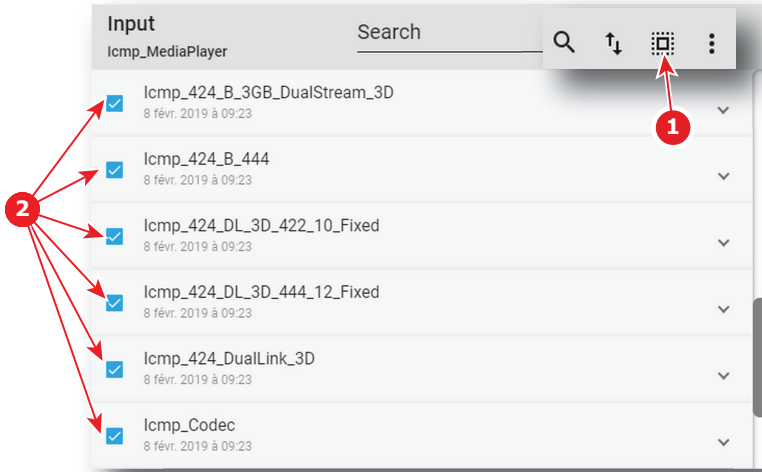

Image 7–123

2. Click on the input file general menu (reference 3) located on the top right of the list. A menu is displayed.

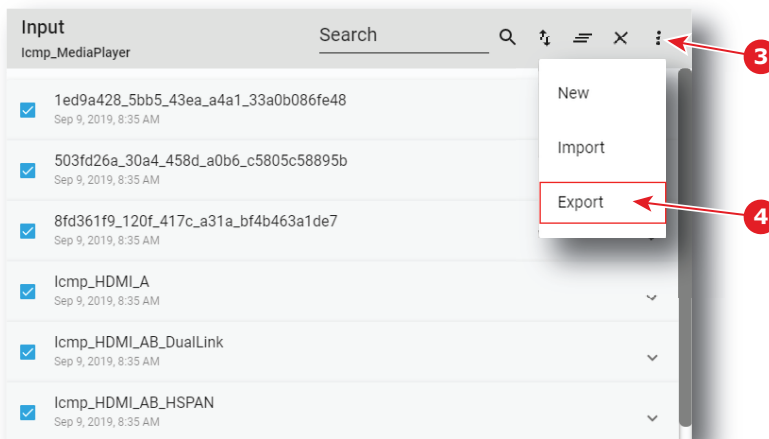

Image 7–124

3. Select **Export** (reference 4) in the menu. *Download package* window is displayed during backup package creation.

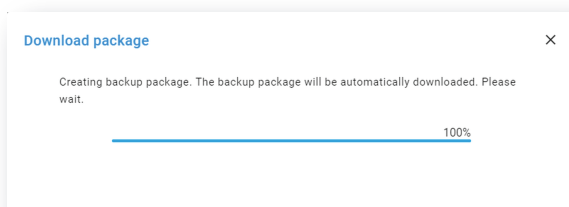

Image 7–125

4. When backup package is created, it is automatically copied in the *Downloads* directory of your computer (e.g. *INPUT-backup-SP4K-15C-2590153431-2019-04-13T104028Z.tar*).

## 7.6.10 Delete an input file

### Location & access

Menu: Configuration > Projector > Input

Level: Administrator, Service technician

### How to delete

1. While in *Configuration > Projector > Input*, find and click on the input file you want to delete.  
The Input file is displayed in its expanded form with menu.

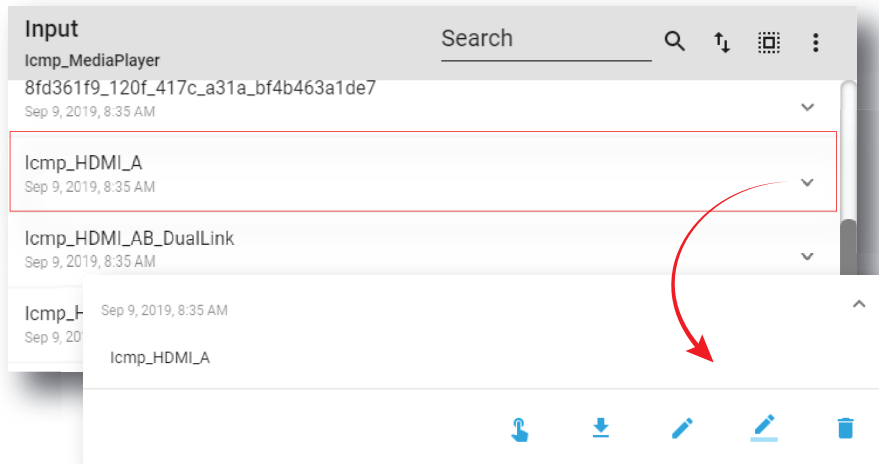

Image 7-126

2. Click the **Delete** icon and confirm with **OK**. 

The input file is removed from the list.

## 7.6.11 Deleting several input files

### Location & access

Menu: Configuration > Projector > Input

Level: Administrator, Service technician

### How to delete several input files

1. While in *Configuration > Projector > Input*, click **Select All** (reference 1) and use the check boxes (reference 2) located at right of the input files in order to select/deselect the files you want to delete.

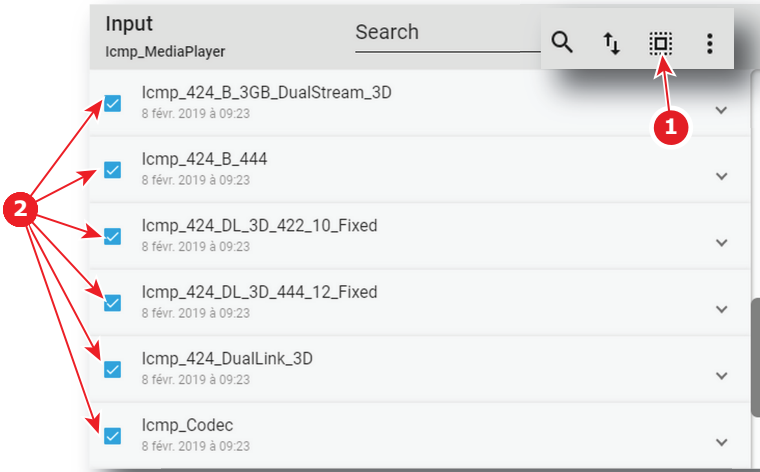

Image 7–127

- Click on the input file general menu located on the top right of the list, then select **Delete** and confirm with **OK**.

The input files selected are definitively removed from the list.

## 7.7 Picture

### 7.7.1 About screen file

#### Location & access

Menu: Configuration > Projector > Picture

Level: Administrator, Service technician

#### Overview

This panel allows to manage screen configuration files. These files contain all data needed to adjust picture on screen. A batch of default files are installed on the projector during the initial setting with the clone package (e. g. FullScreen). Specific screen files could be imported manually.

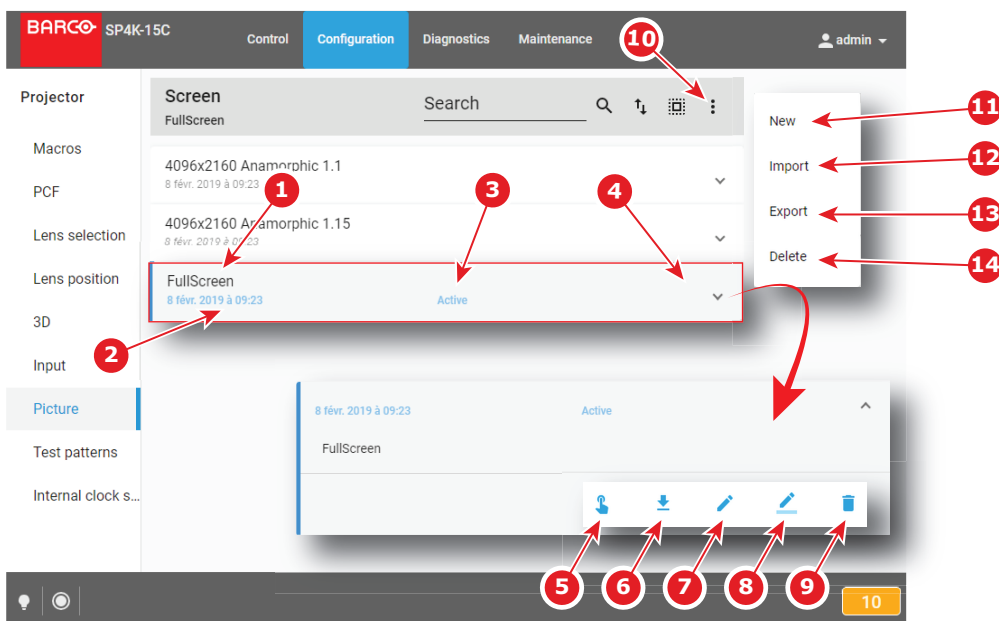

Image 7–128

Each screen file displayed here has a *name* (reference 1). Creation date (reference 2) of the file is displayed just under its name. When a screen file is activated the status (reference 3) turns to *Active* and its name is noticed on top of the list.

Clicking on a screen file (reference 4) in this list allows to show it in its expanded form and displays a contextual menu.

Following actions are available in this menu:

- **Activate** (reference 5) allows to activate the screen file.
- **Export** (reference 6) creates a downloadable backup package.
- **Edit** (reference 7) allows to modify the screen file.
- **Rename** (reference 8) allows to rename the screen file.
- **Delete** (reference 9) allows to remove the screen file from the list.

Clicking on menu (reference 10) displays the screen file general menu.

Following actions are available in this menu:

- **New** (reference 11) allows to create a new screen file.
- **Import** (reference 12) allows to import a screen file.
- **Export** (reference 13) creates a downloadable backup package that contains all screen files selected in the list.
- **Delete** (reference 14) allows to remove several screen files selected in the list.



Click on the name of the active file located on the top of the list to open it directly in edit mode.

## 7.7.2 Creating a screen file

### Location & access

Menu: Configuration > Projector > Picture

Level: Administrator, Service technician

### How to create Input file

1. While in *Configuration > Projector > Picture*, click on the screen file general menu (reference 1) located on the top right of the list.

The menu is displayed.

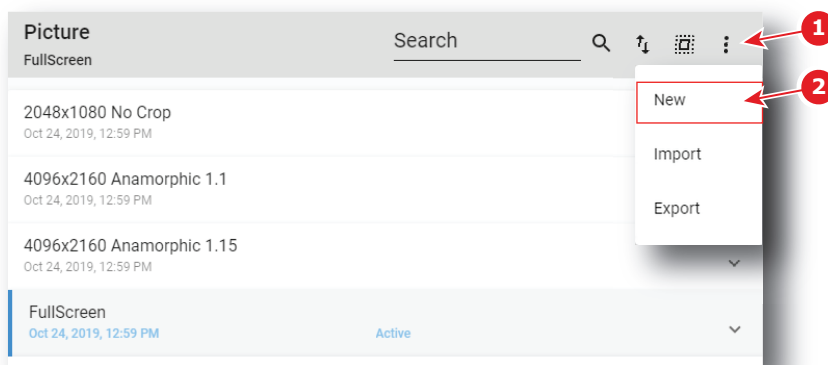

Image 7–129

2. Select **New** (reference 2) in the menu.  
*Screen file* editor (reference 3) is displayed with a new (untitled) input file.



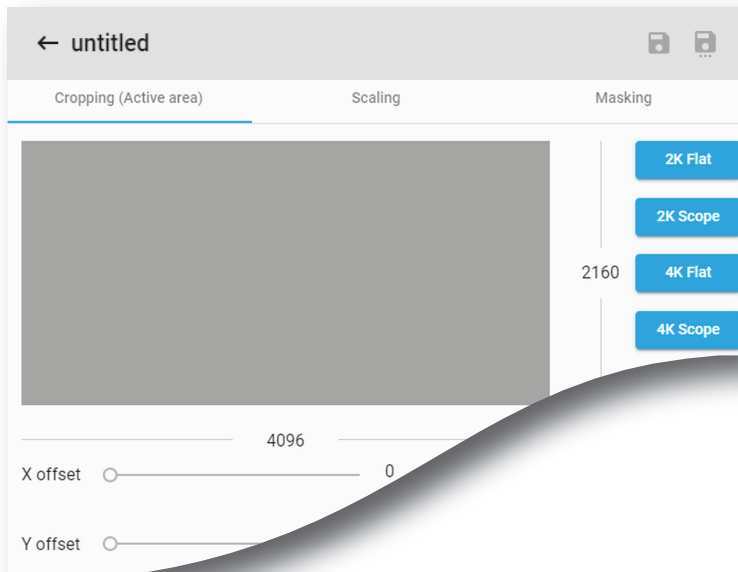

Image 7–130

3. Fill the input file parameters. For more information about the *input file editor*, see “Screen file editor”, page 161.
4. Click **Save As** (reference 3) to display the *Save As* window.

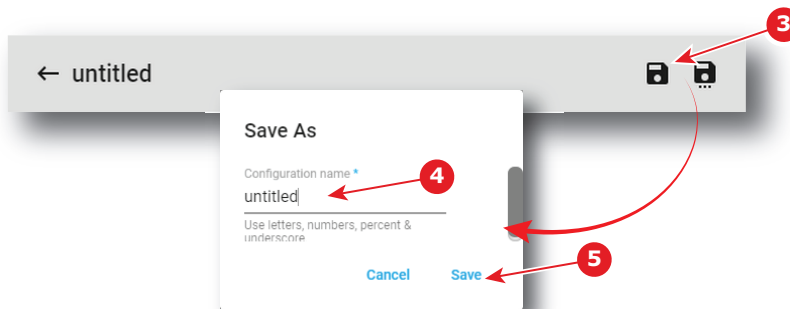



Image 7–131

5. Enter a name (reference 4).
  -  **Note:** List of files already available in the projector is displayed in this window. Directly click on this list allows you to reuse all or part of an already existing file name.
6. Click **save** (reference 5).
  -  **Note:** If the name enter in the previous step already exists, a warning is displayed. Click **Overwrite** to confirm and replace the existing file.

New screen file is added to the screen files list.

## 7.7.3 Screen file editor

### About this chapter

This chapter contains all the necessary information to use screen file editor, the Web Communicator page used to create or modify screen files.

### 7.7.3.1 Cropping (active area)

#### What is cropping

Realize "cropping" means define an active area.

The active area within a source frame equals the relevant movie information within the movie stream. E.g. : 1280 x 1024 movie can be mastered in a 1920 x 1080 stream. Only the 1280 x 1024 frame contains the relevant movie information. In this case, the active area is 1280 x 1024.

The most frequently used active areas are predefined behind shortcuts (e.g. 2K Scope).



The list of predefined shortcuts may be different depending on the type of projector (e.g. 4K shortcut is not present on 2K series projectors).

#### How to crop

1. While in *screen file editor*, click **Cropping** (reference 1).



Image 7-132

2. If you need a predefined active area, click on a shortcut at the right hand of the window (reference 2). *Width* (reference 5) and *Height* (reference 6) are settled with predefined values.  
For a dedicated active area, continue with the next steps.
3. Click on the slider of *Width* (reference 5) and *Height* (reference 6) and drag to set up the active area.  
or  
click on **plus** button or **minus** button of *Width* (reference 5) and *Height* (reference 6) to set up the active area.  
or  
click in the input field of *Width* (reference 5) and *Height* (reference 6) , select the current value and enter a new value with the keyboard to set up the active area.
4. Click on the slider of *X-offset* (reference 3) and *Y-offset* (reference 4) and drag to set the offset.  
or

click on **plus** button or **minus** button of *X-offset* (reference 3) and *Y-offset* (reference 4) to set up the offset.

or

click in the input field of *X-offset* (reference 3) and *Y-offset* (reference 4), select the current value and enter a new value with the keyboard to set the offset.

The offset is referring to the center of the active area and to the center of the source frame.

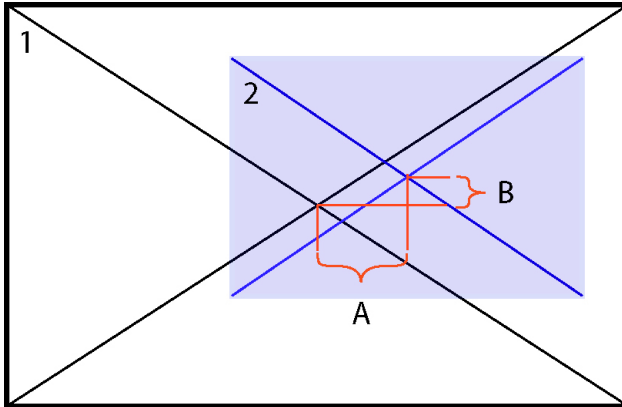

Image 7-133 Center offset indication

- 1 source frame
- 2 Active area on source frame
- A Horizontal offset
- B Vertical offset

5. Click **Discard** (reference 7) allows to remove all the modifications done in the previous steps.

### 7.7.3.2 Scaling

#### What is scaling

With the scaling tool it is possible to adapt the projected image on the screen size (defining the area available for image display). So, look always to the screen when scaling the image. The projector will always attempt to keep the image centered within this defined area, and the correct aspect ratio of the image will always be preserved.



As the projector project an image under an angle, the original image will be shown as trapezium. The image will be squared with the masking function by masking the shaded areas.

#### How to scale

1. While in *screen file editor*, click **Scaling** (reference 1).

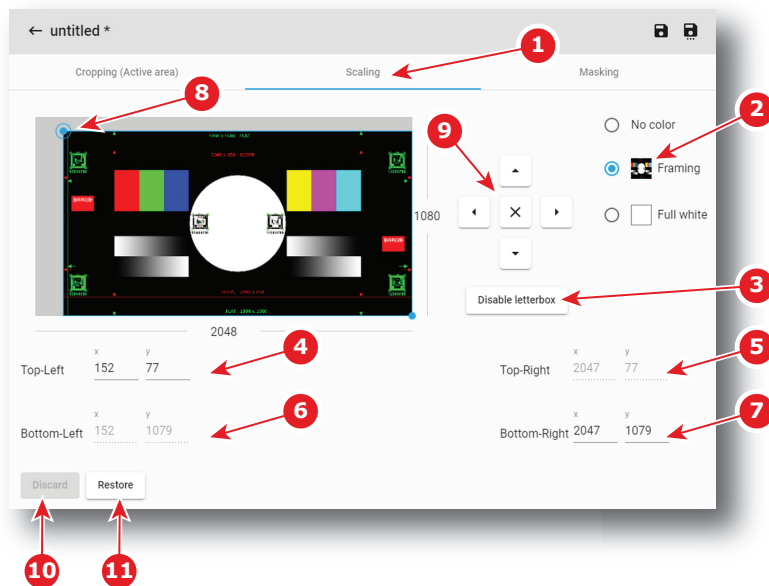



Image 7-134

2. Select a **Test pattern** (reference 2) to display a test pattern on screen.
3. Enable or disable **letterbox** (reference 3) to determine how the image will be displayed. Enabled **letterbox** allows to preserve the film's original aspect ratio. For more details see section dedicated to letterbox after this procedure.
4. Set the position the *Top-Left* corner and *Bottom-Right* corner by using numeric values. Position the four corners of the picture on the four corners of the screen.
  1. Click in the input fields for X and Y of *Top-Left* corner (reference 4) and fill out the desired position value (or use up down control of spin box near the input field).
  2. Redo the same operation with the *Bottom-Right* corner (reference 7). *Top-Right* corner (reference 5) and *Bottom-Left* corner (reference 6) cannot be modified: these fields are automatically updated depending on the actions on the other two fields.

or

Set the position the 4 corners manually by using arrows (reference 9):

1. Click on *Top-Left* corner (reference 8) to select it, then use up/down/left/right arrows (reference 9) to reach the desired position.
2. Redo the same operation with the *Bottom-Right* corner.

 *Tip:* Combination of these arrows with [SHIFT] or [ALT] keys on keyboard allows to optimizing positioning. See following section dedicated to *positioning accelerator*.

5. Click **Discard** (reference 10) allows to remove all the modifications done in the previous step.
6. Click **Restore** (reference 11) allows to reset the scaling (zero position).

### Positioning accelerator

Manually positioning corners could be fastidious, especially if the new position is far to the previous one. To avoid this, some keyboard combination are available to accelerate positioning.

To speed up the positioning by factor of x10 , use up/down/left/right arrows on the screen in combination with the **[SHIFT]** key on the keyboard. With this combination the displacements will be 10 pixels for each click.

To speed up the positioning by factor of x100 , use up/down/left/right arrows on the screen in combination with the **[ALT]** key on the keyboard. With this combination the displacements will be 100 pixels for each click.



Another way to optimize movement during positioning is push on one up/down/left/right arrows on the screen but not release (stay pressed). This action allows to obtain a displacement with speed that increased until release.

## Letterbox

The letterbox function determines how the image will be displayed.

If Letterbox enabled is checked, the system will show all of the original image data on the screen. This may require that the system letterbox the image, either on the top and bottom, or left and right side.

If Letterbox enabled is not checked, the system will fill all the screen with image data. This may require that the system discard image data, either from the top and bottom, or the left and right side.

The following two examples show what will be displayed based on the state of the letterbox function.

### Example with letterbox enabled

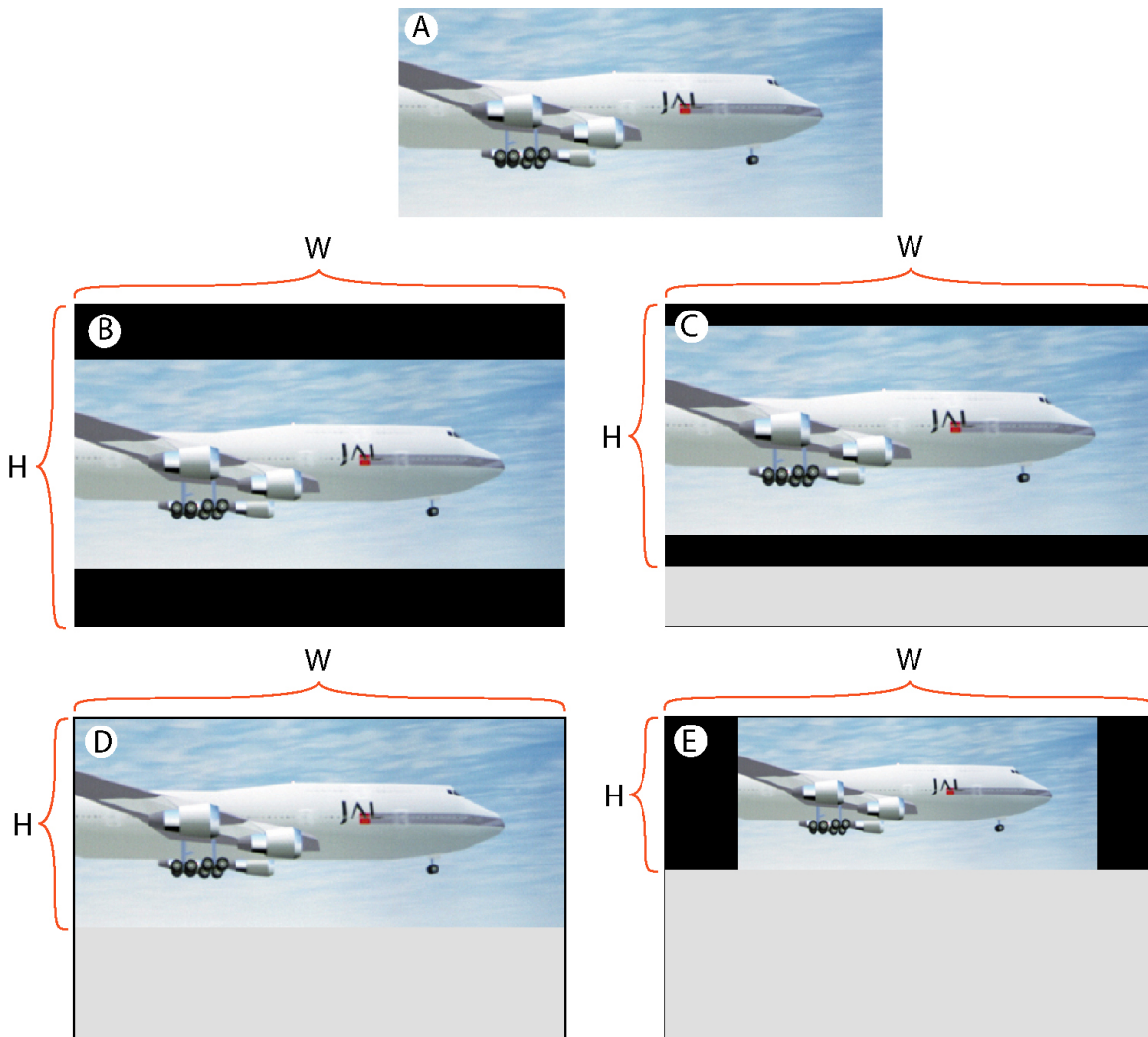

Image 7-135 Example letterboxing enabled

W and H are width and height of the resized area.

- A : input source
- B :
  - Resized area equals the maximum DMD size
  - The input image has a different aspect ratio from the resized area.
  - Full image is letterboxed (top and bottom) and centered within the resized area.
- C :
  - The screen height is narrowed, bottom is moved upwards.
  - The input image has a different aspect ratio from the resized area.
  - Full image is letterboxed (top and bottom) and centered within the resized area.
- D :
  - Bottom of resized area is moved upward to where image fills this area.

- The input image has now the same aspect ratio from the resized area.
- Full input image centered within the resized area and letterboxing is not required.
- E :
  - Bottom of resized area has moved upward to where image at previous size cannot be fully displayed.
  - Resized area reduced in both directions (maintaining aspect ratio) so full scaled image can be displayed.
  - Image is letterboxed ( right side and left side).

### Example with letterbox disabled

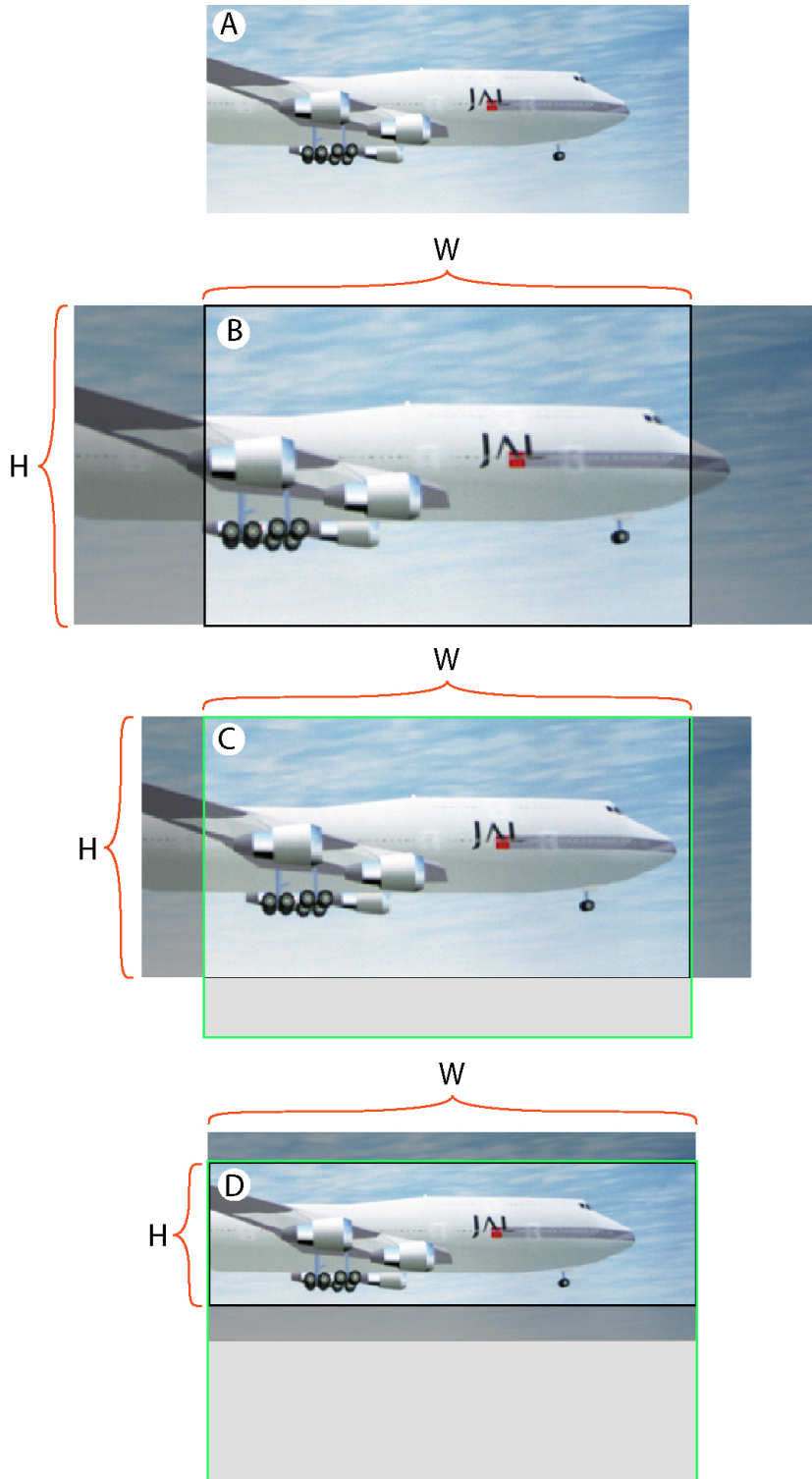

Image 7-136 Example letterboxing disabled

W and H are width and height of the resized area.

- A : input source
- B :
  - Resized area equals the maximum DMD size
  - The input image has a different aspect ratio from the resized area.
  - Image is scaled up to fill resized area, requiring that some input data be discarded because it falls outside the resized area (dark transparent areas left and right).
- C :
  - Bottom of resized area has moved upward.
  - The input image has a different aspect ratio from the resized area.
  - Image is scaled up to fill resized area, requiring that some input data be discarded because it falls outside the resized area (dark transparent areas left and right).
- D :
  - Bottom of resized area has moved upward so that the height is smaller than the image height.
  - The input image has a different aspect ratio from the resized area.
  - Input image is not scaled, however, data at the top of the image must be discarded because it falls outside of the resized area, and data at the bottom of the image must be discarded because it falls outside the resized area.

### 7.7.3.3 Masking

#### What is masking

After resizing the image, it may be still need to mask away pixels on the screen due to keystone and/or bow distortion of the projected image. So look always at the screen while masking pixels.

#### How to mask

1. While in *screen file editor*, click **Masking** (reference 1).

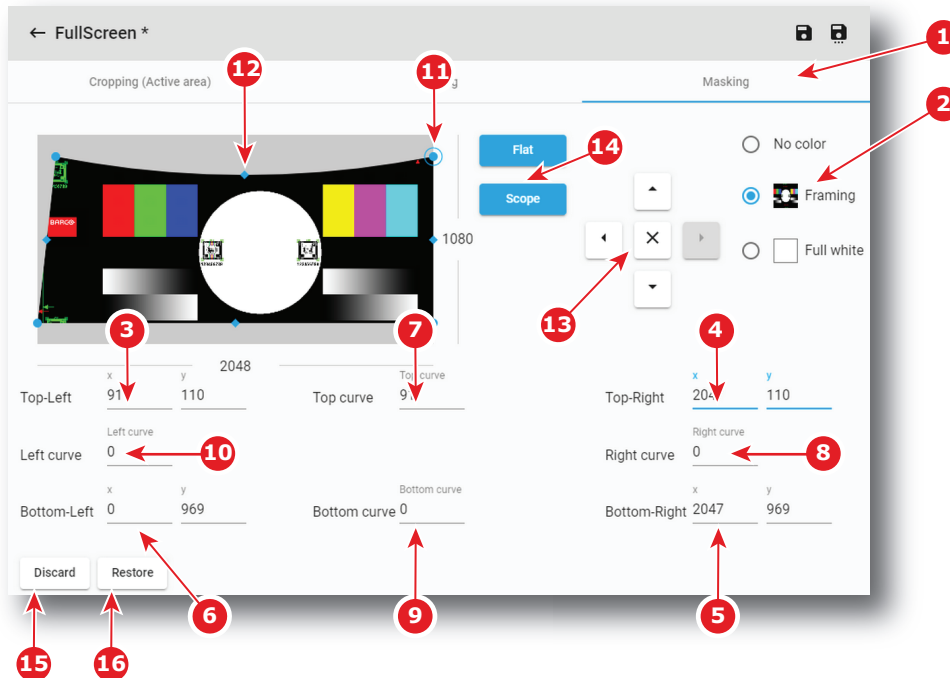

Image 7-137

2. Select a **Test pattern** (reference 2) to display a test pattern on screen.
3. If you need a predefined shape of masking, click on a shortcut (reference 14) at the right of the screen representation.

4. Set the position the 4 corners by using numeric values. Fit the corners of the picture on the four corners of the screen by blanking the pixels displayed outside of the screen.
  1. Click in the input fields for X and Y of *Top-Left* corner (reference 3) and fill out the desired position value (or use up down control of spin box near the input field).
  2. Redo the same operation with the other corners: *Top-Right* corner (reference 4), *Bottom-Right* corner (reference 5), *Bottom-Left* corner (reference 6).

or

Set the position the 4 corners manually by using arrows (reference 13):

1. Click on a corner (e.g. reference 11) to select it, then use up/down/left/right arrows (reference 13) to reach the desired position.
2. Redo the same operation with the other corners.



*Tip:* Combination of these arrows with [SHIFT] or [ALT] keys on keyboard allows to optimizing positioning. See section dedicated to *positioning accelerator* in “[Scaling](#)”, page 163.

5. Set the 4 sides alignment by using numeric values. Fit the four sides of the picture to the four sides of the screen by blanking the pixels displayed outside of the screen. This setting is mainly used on curve screens.
  1. Click on the input field of the *Top curve* (reference 7) and enter the curve factor (or use up down control of spin box near the input field).
  2. Redo the same operation with the other curves: *Right curve* (reference 8), *Bottom curve* (reference 9), *Left curve* (reference 10).

or

Set the 4 sides alignment manually by using arrows (reference 13):

1. Click on a side/curve (e.g. reference 12) to select it, then use up/down/left/right arrows (reference 13) to reach the desired position.
2. Redo the same operation with the other side/curves.



*Tip:* Combination of these arrows with [SHIFT] or [ALT] keys on keyboard allows to optimizing positioning. See section dedicated to *positioning accelerator* in “[Scaling](#)”, page 163.

6. Click **Discard** (reference 15) allows to remove all the modifications done in the previous steps.
7. Click **Restore** (reference 16) allows to reset the masking (zero position).

## 7.7.4 Editing a Screen file

### Location & access

Menu: Configuration > Projector > Picture

Level: Administrator, Service technician

### How to edit

1. While in *Configuration > Projector > Picture*, find and click on the screen file you want to edit.  
The screen file is displayed in its expanded form with menu.



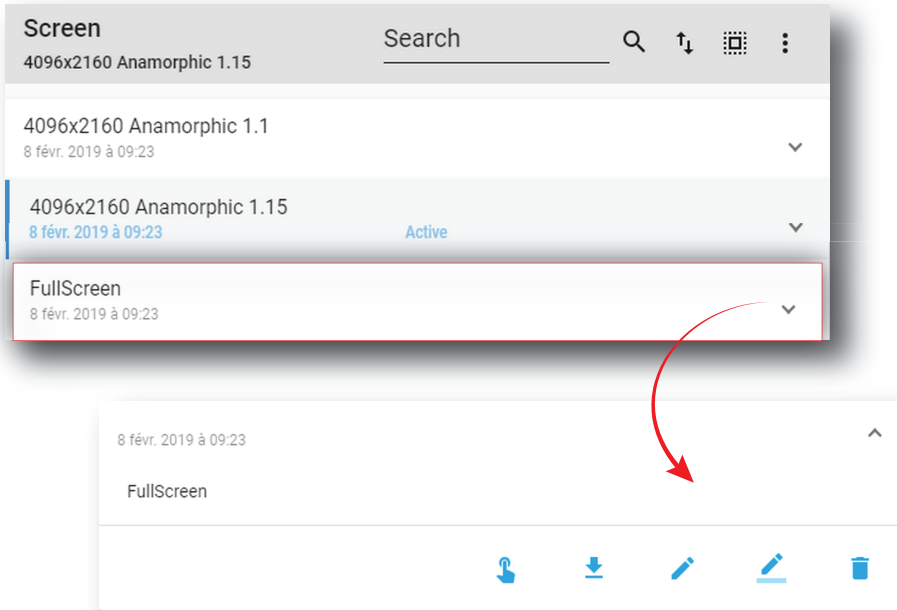



Image 7–138

2. Click **Edit** in the menu. 

The screen file is displayed in *screen file editor*.

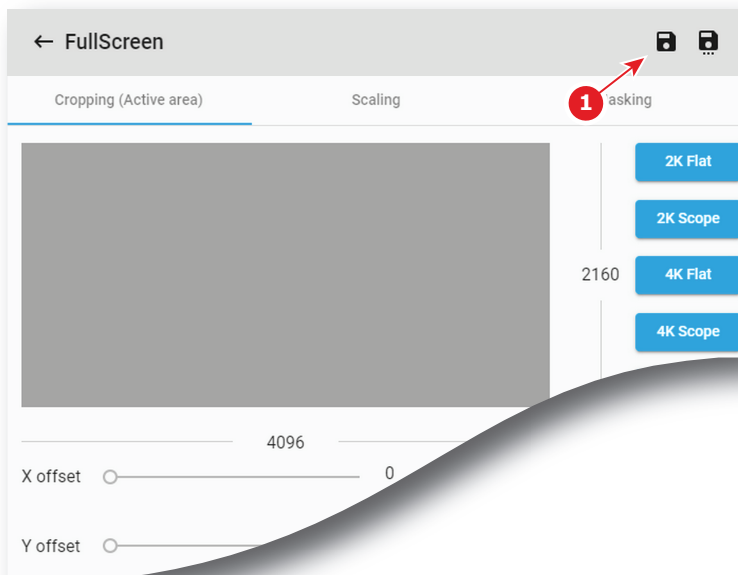

Image 7–139

3. Modify the screen file parameters. For more information about the *screen file editor*, see “[Screen file editor](#)”, page 161.
4. Click **Save** (reference 1).

## 7.7.5 Activating a screen file

### Location & access

Menu: Configuration > Projector > Picture

Level: Administrator, Service technician

## What is possible

Usually a screen file is activated via a macro but it is possible to directly activate a screen file by clicking on **Activate** in the contextual menu.

## How to activate

1. While in *Configuration > Projector > Picture*, find and click on the screen file you want to activate.

The screen file is displayed in its expanded form with menu.

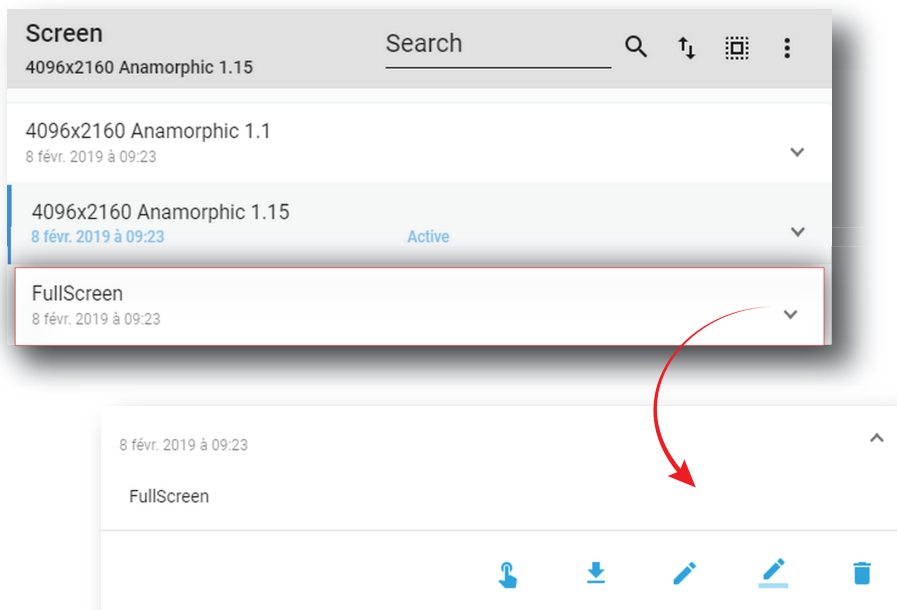

Image 7-140

2. Click **Activate** in the menu.



The new configuration is applied. Status of the screen file turns to *Active* and its name is noticed on top of the list.

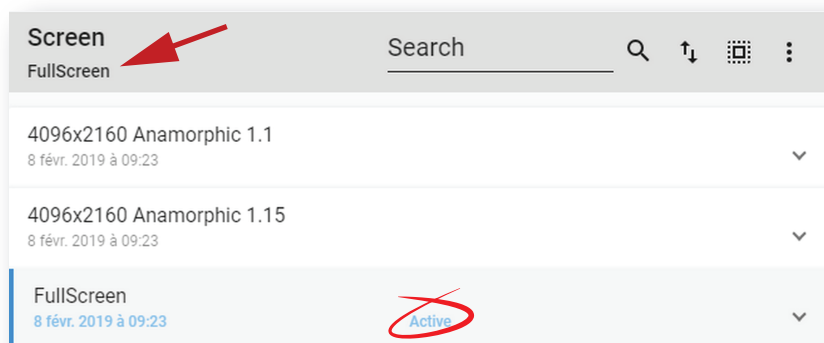

Image 7-141



Click on the name of the active file located on the top of the list to open it directly in edit mode.

## 7.7.6 Renaming a screen file

### Location & access

Menu: Configuration > Projector > Picture

Level: Administrator, Service technician

### How to rename

1. While in *Configuration > Projector > Picture*, find and click on the screen file you want to rename.  
The screen file is displayed in its expanded form with menu.

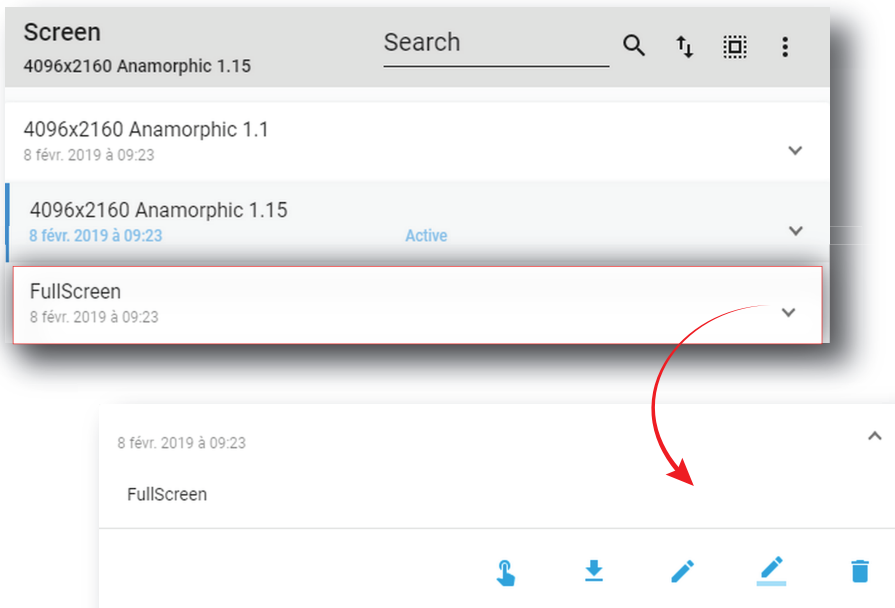



Image 7-142

2. Click **Rename** in the menu.   
*Rename* window is displayed.

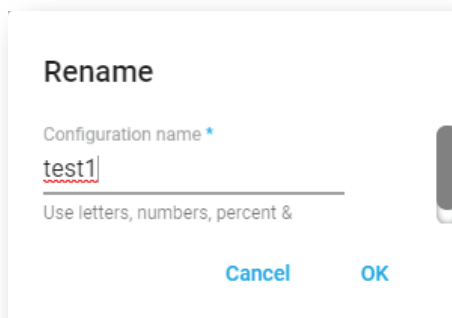

Image 7-143

3. Enter a new name and click **OK**.

## 7.7.7 Importing a screen file

### Location & access

Menu: Configuration > Projector > Picture

Level: Administrator, Service technician

### How to import a screen file

1. While in *Configuration > Projector > Picture*, click on the screen file general menu (reference 1) located on the top right of the list.

The menu is displayed.

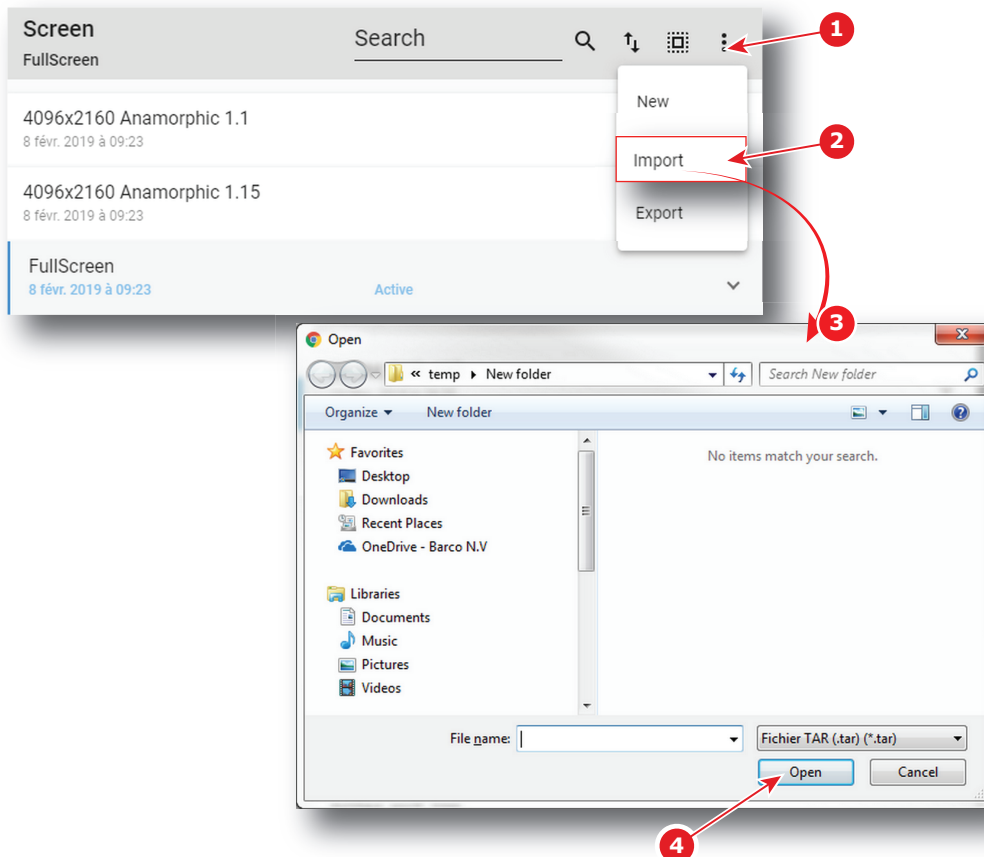

Image 7-144

2. Select **Import** (reference 2) in the menu.  
*Open* window (reference 3) is displayed
3. Locate and select the screen file.
4. Click **Open** (reference 4).  
The screen file is imported and added to the files list.

## 7.7.8 Exporting a screen file

### Location & access

Menu: Configuration > Projector > Picture

Level: Administrator, Service technician

## How to export a screen file

1. While in *Configuration > Projector > Picture*, find and click on the screen file you want to export.  
The screen file is displayed in its expanded form with menu.

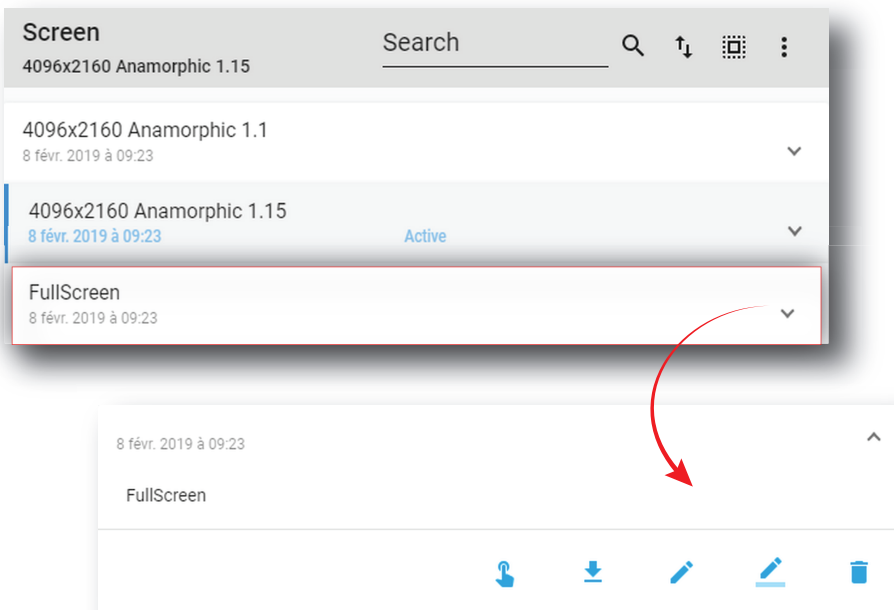



Image 7–145

2. Click **Export** in the menu.   
*Download package* window is displayed during backup package creation.

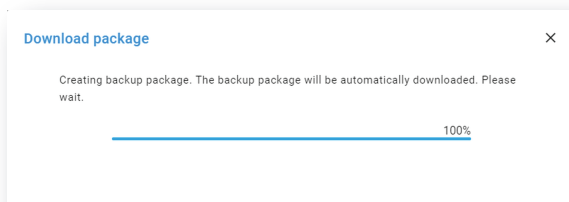

Image 7–146

3. When backup package is created, it is automatically copied in the *Downloads* directory of your computer (e.g. *SCREEN-backup-SP4K-15C-2590153431-2019-04-14T133742Z.tar*).

## 7.7.9 Exporting several screen files in a backup package

### What is possible

Several screen files could be exported at once in a backup package.

### Location & access

Menu: Configuration > Projector > Picture

Level: Administrator, Service technician

## How to create and export backup package of screen files

1. While in *Configuration > Projector > Picture*, click **Select All** (reference 1) and use the check boxes (reference 2) located at right of the screen files in order to select/deselect the files you want to export.

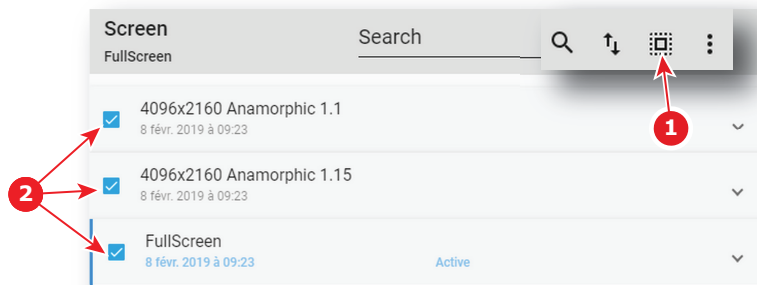

Image 7-147

2. Click on the screen file general menu (reference 3) located on the top right of the list. A menu is displayed.

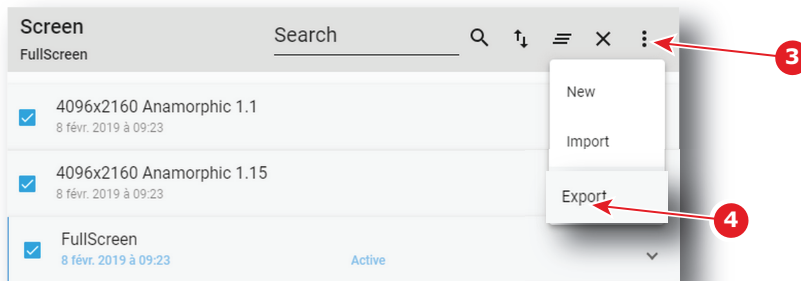

Image 7-148

3. Select **Export** (reference 4) in the menu. *Download package* window is displayed during backup package creation.

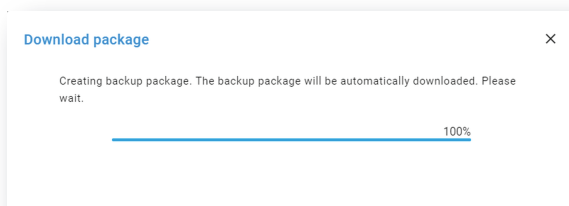

Image 7-149

4. When backup package is created, it is automatically copied in the *Downloads* directory of your computer (e.g. *SCREEN-backup-SP4K-15C-2590153431-2019-04-14T133742Z.tar*).

### 7.7.10 Delete a screen file

#### Location & access

Menu: Configuration > Projector > Picture

Level: Administrator, Service technician

#### How to delete

1. While in *Configuration > Projector > Picture*, find and click on the screen file you want to delete.

The screen file is displayed in its expanded form with menu.

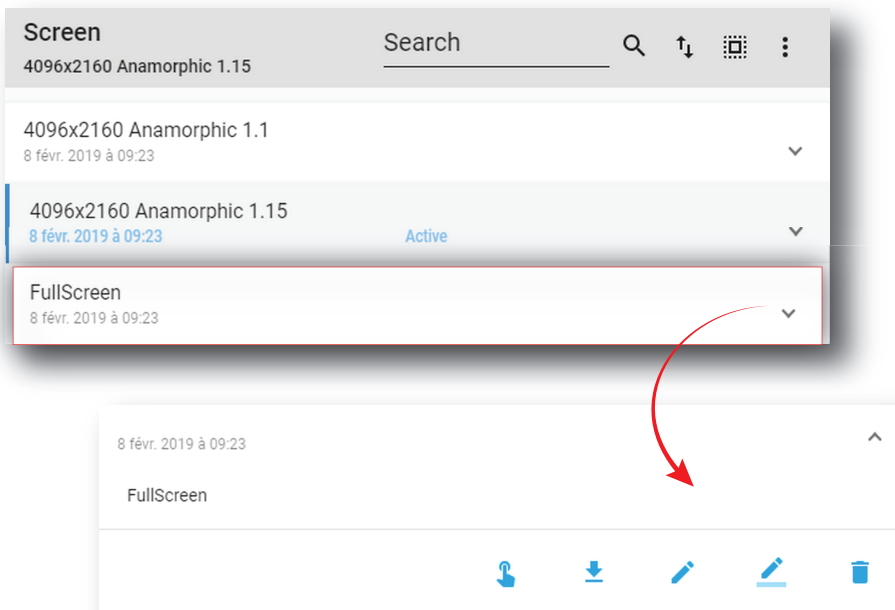

Image 7–150

2. Click the **Delete** icon and confirm with **OK**.



The screen file is removed from the list.

## 7.7.11 Deleting several screen files

### Location & access

Menu: Configuration > Projector > Picture

Level: Administrator, Service technician

### How to delete several screen files

1. While in *Configuration > Projector > Picture*, click **Select All** (reference 1) and use the check boxes (reference 2) located at right of the screen files in order to select/deselect the files you want to delete.

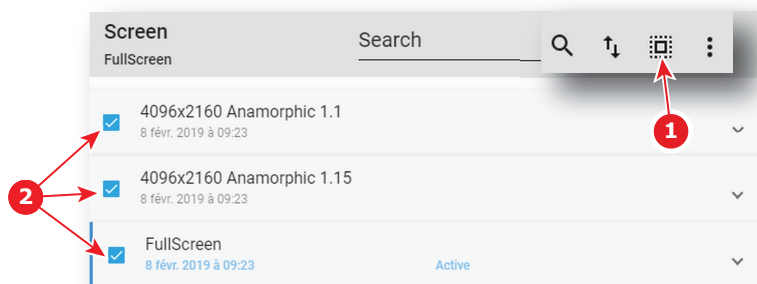

Image 7–151

2. Click on the screen file general menu located on the top right of the list, then select **Delete** and confirm with **OK**.

The screen files selected are definitively removed from the list.

## 7.8 Test patterns

### 7.8.1 About test patterns

#### Location & access

Menu: Configuration > Projector > Test Patterns

Level: Administrator, Service technician

#### Overview

This panel allows to manage test patterns of the projector.

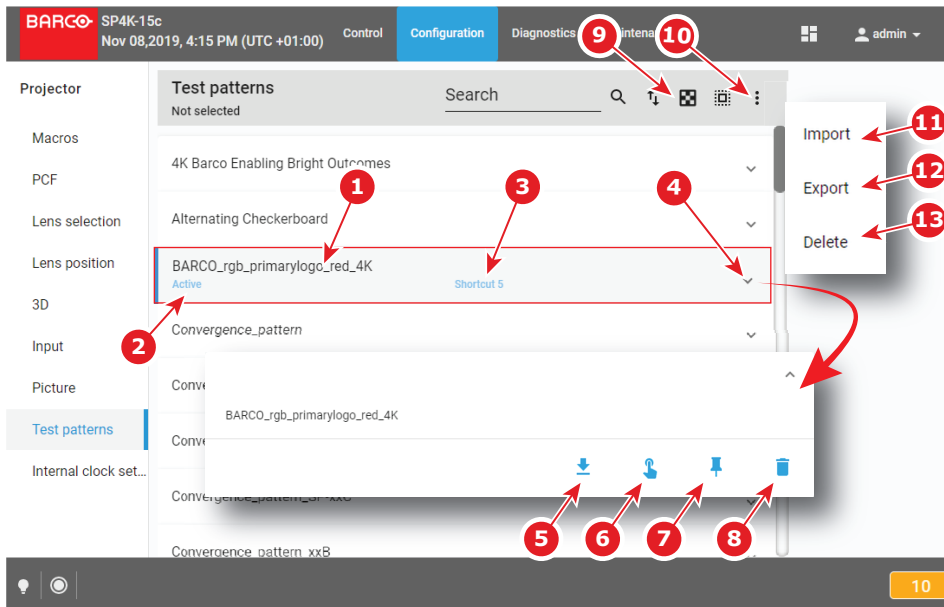

Image 7–152

Each test pattern displayed in this menu has a *Name* (reference 1). When a test pattern is selected the status of the test pattern (reference 2) turns to *Selected* and its name is noticed on top of the list. On the status bar, a icon blinks in green when a test pattern is activated.

Predefined patterns can be quickly selected via the shortcuts (e. g. *Control panel* in *Web Commander* software). If a test pattern is associated to shortcut, the shortcut name (reference 3) is specified on the test pattern.

Clicking on a test pattern (reference 4) in this list allows to show it in its expanded form and displays a contextual menu.

Following actions are available in this menu:

- **Export** (reference 5) copies the .PNG file in the *Downloads* directory of your computer.
- **Activate/Deactivate** (reference 6) allows to display (/remove) the test pattern on (/from) the screen.
- **Create/Delete** shortcut (reference 7) allows to associate (/unlink) test pattern to (/from) a shortcut.
- **Trash bin** icon (reference 8) allows to remove test pattern from the list.

Clicking on **Off TestPattern** (reference 9) located on the top right of the list allows to deselect current test pattern without retrieve it in the list.

Clicking on menu (reference 10) displays the test patterns general menu.

Following actions are available in this menu:

- **Import** (reference 11) allows to import a test pattern (.PNG) alone (one single file), or a package of test patterns (.tar) with several files inside.
- **Export** (reference 12) creates a downloadable backup package that contains all test patterns selected, then copies this package in the *Downloads* directory of your computer.
- **Delete** (reference 13) allows to remove several test patterns selected in the list.



## 7.8.2 Activating a test pattern using configuration menu

### Location & access

Menu: Configuration > Projector > Test Patterns

Level: Administrator, Service technician

### How to activate

1. While in Configuration > Projector > Test patterns, find and click on the test pattern you want to activate. The test patterns is displayed in its expanded form with menu.

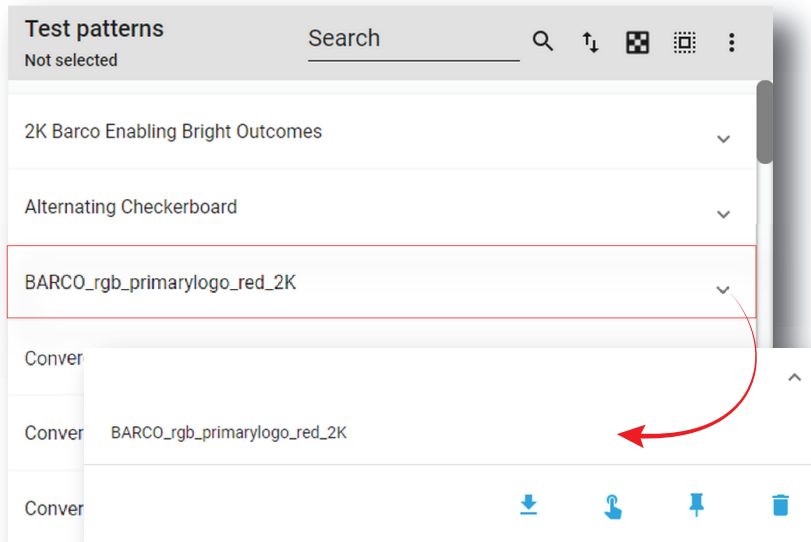

Image 7–153

2. Click **Activate** in the menu. 

The Test patterns is activated. Status of the test patterns turns to *Active* and its name is noticed on top of the list.

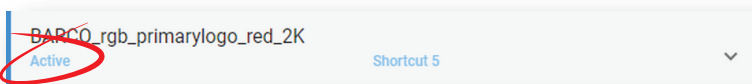

Image 7–154

On the status bar, a icon blinks in green when a test pattern is activated.

## 7.8.3 Deactivating a test pattern using configuration menu

### Location & access

Menu: Configuration > Projector > Test Patterns

Level: Administrator, Service technician

### How to deactivate

1. While in Configuration > Projector > Test patterns, find and click on the test pattern you want to deactivate. The test patterns is displayed in its expanded form with menu.

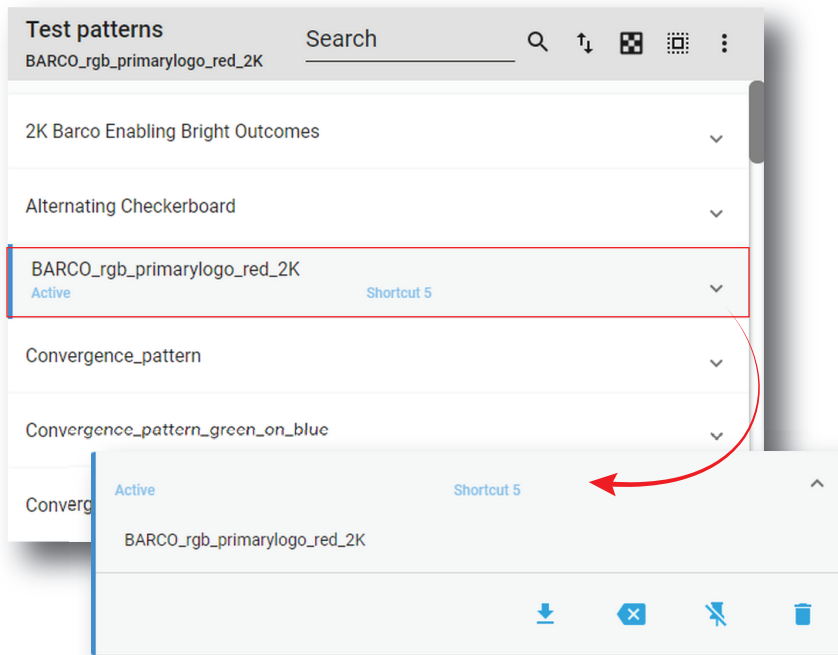

Image 7-155

2. Click **Deactivate** in the menu.



The Test patterns is deactivated. *Active* status is removed from the test pattern and “Not selected” is noticed on top of the list.

On the status bar, the icon related to test pattern is removed.

## 7.8.4 Assign a test pattern to a shortcut

### Location & access

Menu: Configuration > Projector > Test Patterns

Level: Administrator, Service technician

### How to assign a test pattern to a shortcut number

1. While in *Configuration > Projector > Test pattern*, find and click on the test pattern you want to link with a shortcut.

The test pattern is displayed in its expanded form with menu.

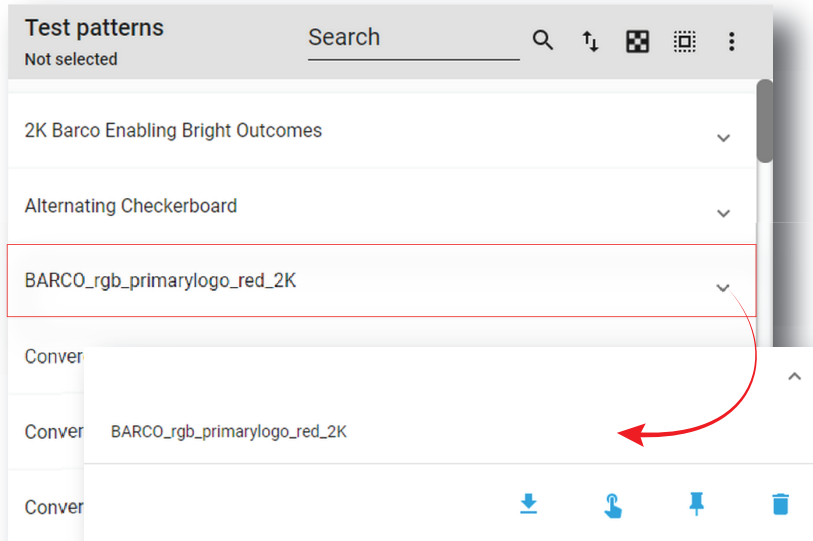



Image 7–156

2. Click **Create shortcut** in the menu.    
*Assign to test pattern shortcut* window is displayed and invite you to select a shortcut.

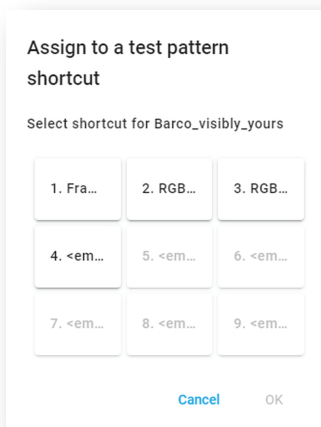

Image 7–157

3. Choose a shortcut button not already assigned to a test pattern (e.g. 2) then click **OK**.   
 Test pattern is now linked with a shortcut and the shortcut number is displayed on the test pattern.

## 7.8.5 Removing a test pattern from a shortcut

### Location & access

Menu: Configuration > Projector > Test Patterns

Level: Administrator, Service technician

### How to unlink a test pattern from a shortcut number

1. While in *Configuration > Projector > Test patterns*, find and click on the test pattern you want to unlink.   
 The test patterns is displayed in its expanded form with menu.

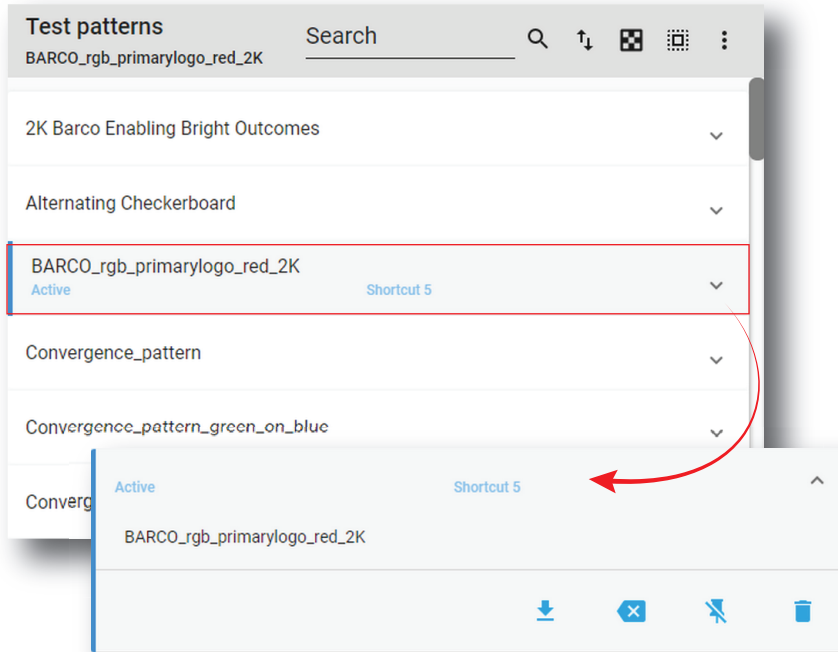

Image 7-158

2. Click **Delete shortcut** in the menu. 

Test pattern is no longer associated with shortcut (e. g. *Shortcut 2*) and shortcut name is removed from the test pattern.

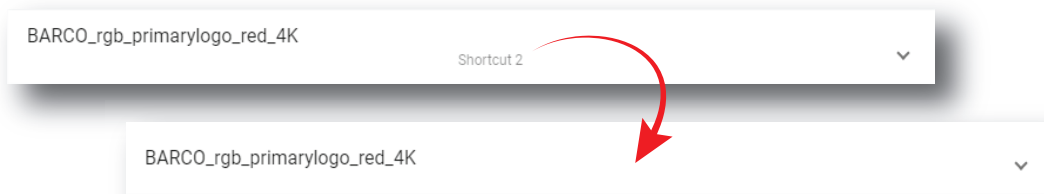

Image 7-159

## 7.8.6 Importing a test pattern

### Location & access

Menu: Configuration > Projector > Test Patterns

Level: Administrator, Service technician

### How to import a test pattern

1. While in *Configuration > Projector > Test patterns*, click on the test pattern general menu (reference 1) located on the top right of the list.  
Test patterns menu is displayed.

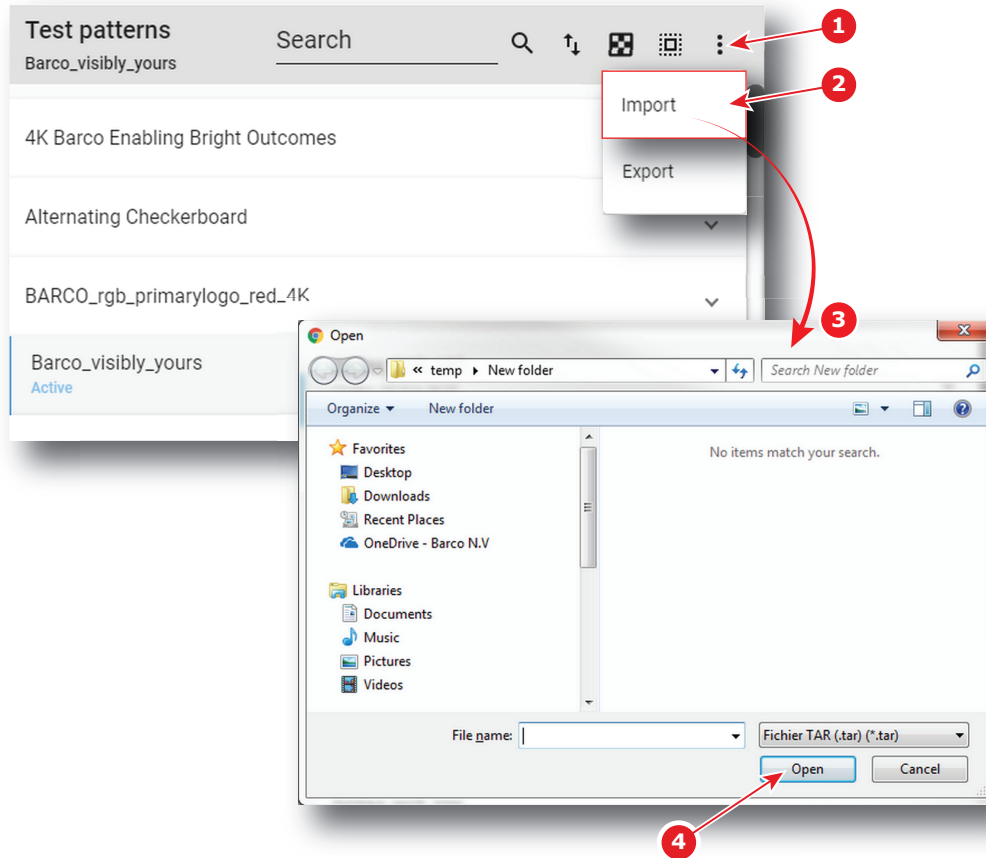

Image 7-160

2. Select **Import** (reference 2) in the menu.  
Open window (reference 3) is displayed
3. Locate and select a test pattern (.PNG) alone (one single file), or a package of test patterns (.tar) with several files inside.
4. Click **Open** (reference 4).  
Selected files are imported and added to the list.



If a file has the same name as a file already present, a confirmation will be required before overwriting.

## 7.8.7 Exporting a test pattern

### Location & access

Menu: Configuration > Projector > Test Patterns

Level: Administrator, Service technician

### How to export a test pattern

1. While in *Configuration > Projector > Test pattern*, find and click on the test pattern you want to export.  
The test pattern is displayed in its expanded form with menu.

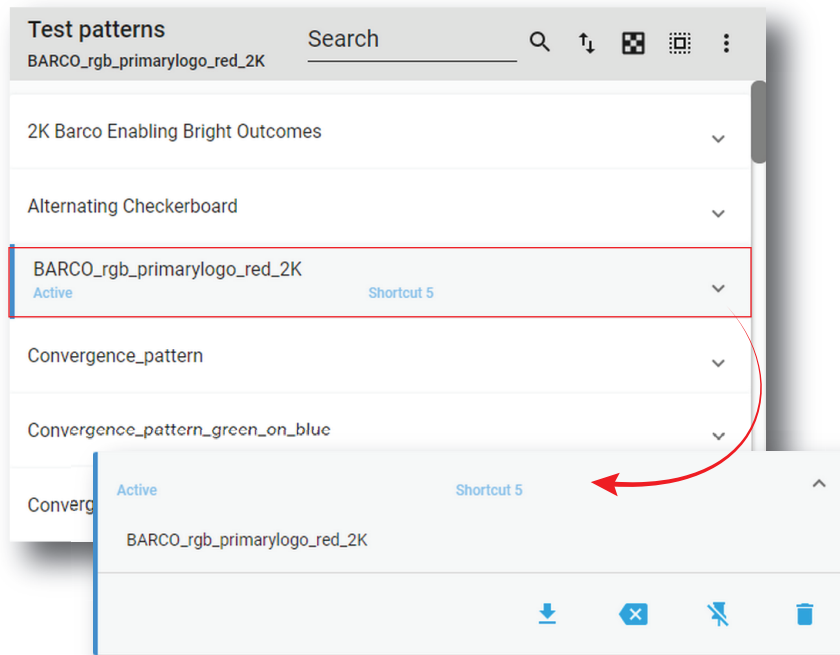

Image 7-161

2. Click **Export** in the menu.



Test pattern file (.PNG) is created and automatically copied in the *Downloads* directory of your computer (e.g. *BARCO\_rgb\_primarylogo\_red\_2K.PNG*).

## 7.8.8 Exporting several test patterns in a backup package

### Location & access

Menu: Configuration > Projector > Test Patterns

Level: Administrator, Service technician

### How to create and export backup package of test patterns

1. While in *Configuration > Projector > Test patterns*, click **Select All** (reference 1) and use the check boxes (reference 2) located at right of the test patterns in order to select/deselect the test pattern files you want to export.

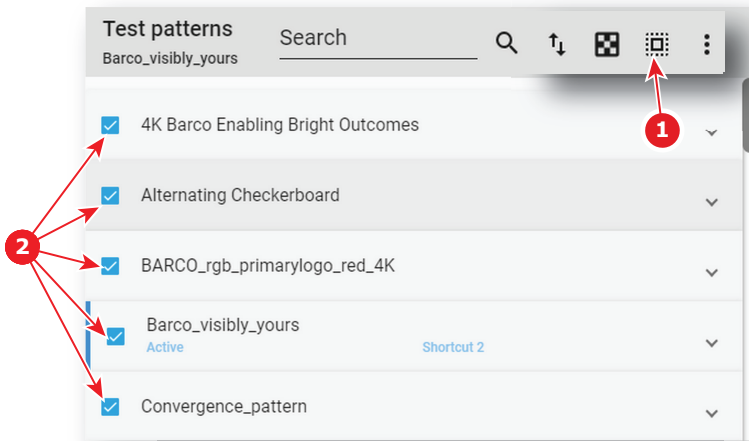

Image 7-162

2. Click on the Test patterns general menu (reference 3) located on the top right of the list. Test pattern general menu is displayed.

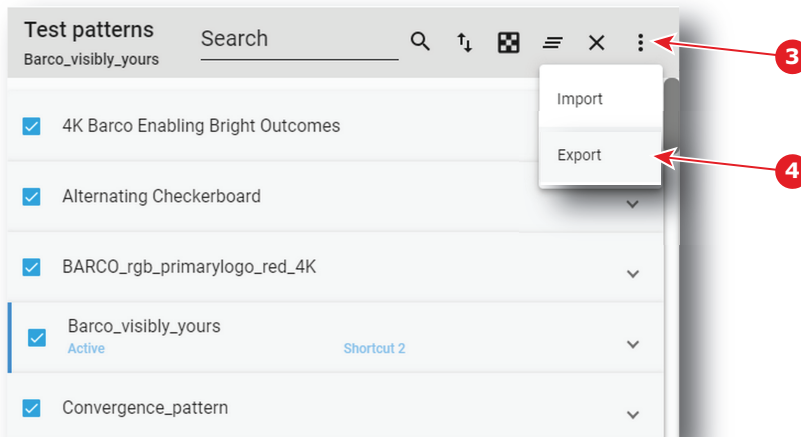

Image 7-163

3. Select **Export** (reference 4) in the menu. *Download package* window is displayed during backup package creation.

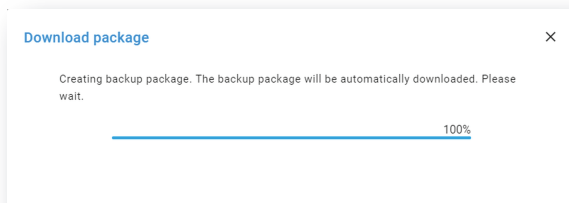

Image 7-164

4. When backup package is created, it is automatically copied in the *Downloads* directory of your computer (e.g. *TESTPATTERN-backup-SP4K-15C-2590153431-2019-04-09T134843Z.tar*).

## 7.8.9 Delete a test pattern

### Location & access

Menu: Configuration > Projector > Test Patterns

Level: Administrator, Service technician

### How to delete

1. While in *Configuration > Projector > Test pattern*, find and click on the test pattern you want to delete. The test pattern is displayed in its expanded form with menu.

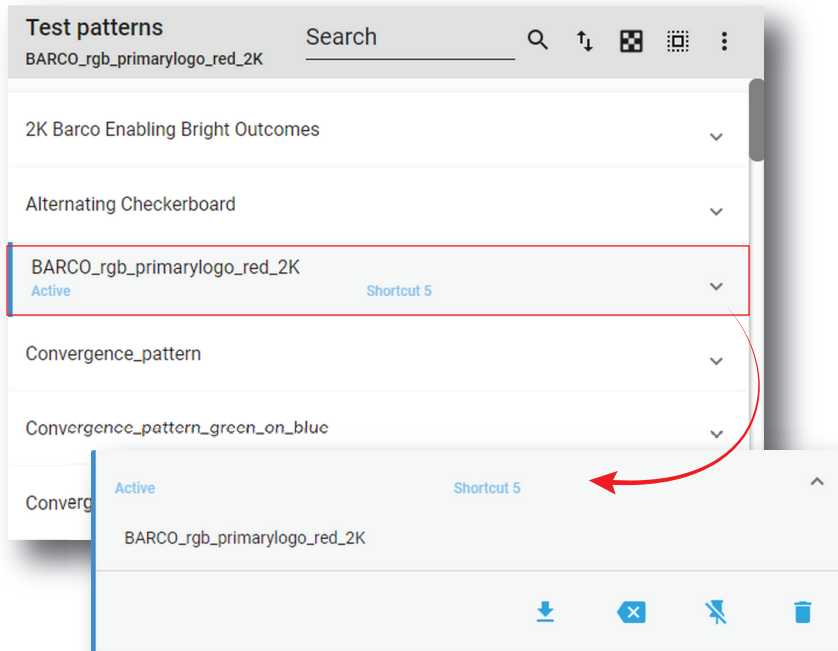

Image 7-165

2. Click the **Delete** icon and confirm with **OK**. 

The file is removed from the list.

## 7.8.10 Deleting several test pattern files

### Location & access

Menu: Configuration > Projector > Test Patterns

Level: Administrator, Service technician

### How to delete several test pattern files

1. While in *Configuration > Projector > Test patterns*, click **Select All** (reference 1) and use the check boxes (reference 2) located at right of the test patterns in order to select/deselect the test pattern files you want to delete.



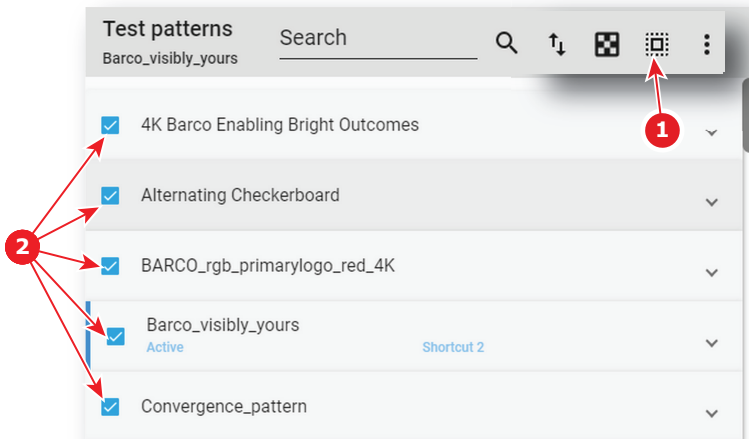

Image 7-166

- Click on the test pattern general menu located on the top right of the list, then select **Delete** and confirm with **OK**.

The test patterns selected are definitively removed from the list.

## 7.9 Internal clock settings

### 7.9.1 About Internal clock settings

#### Location & access

Menu: Configuration > Projector > Internal clock settings

Level: Administrator, Service technician

#### Overview



Only available when the projector is equipped with an ICMP.

This panel allows you to adjust the internal clock.

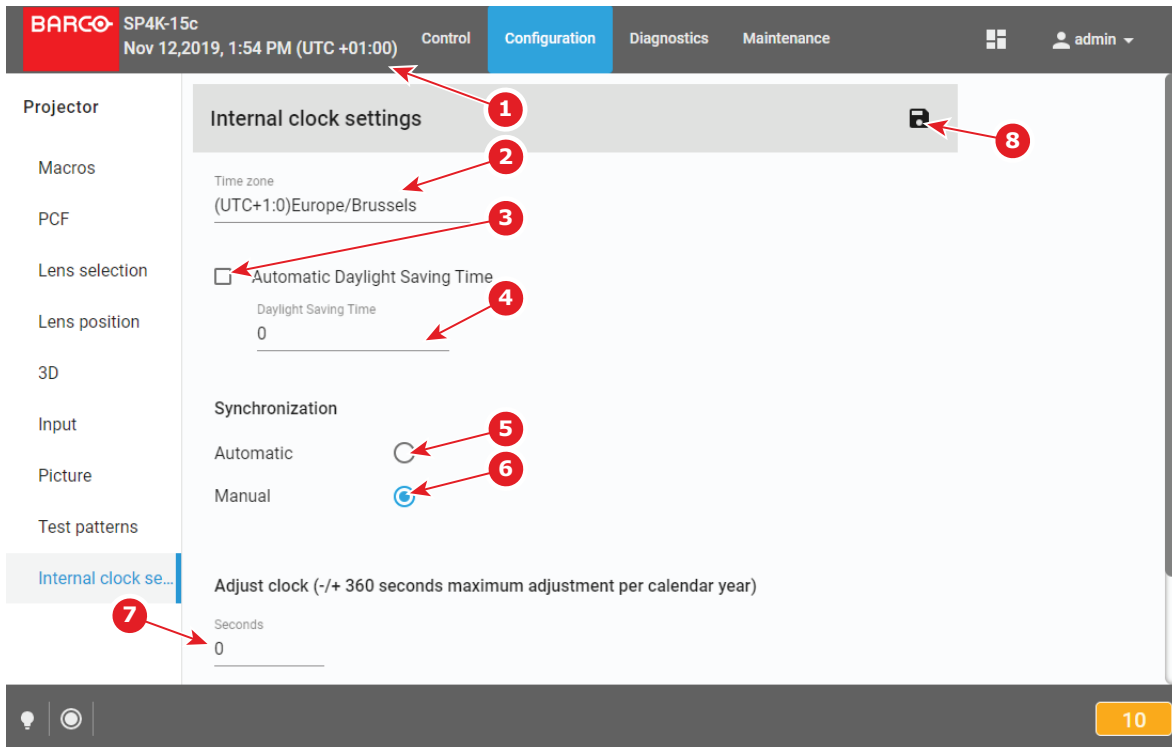

Image 7-167

The clock indication (reference 1) next to local time indicates the local time as set by selecting the local time zone (reference 2).

Automatic Daylight saving time mechanism can be enabled or disabled (reference 3). If disabled, the daylight saving time must be adjusted manually (reference 4).

To limit a clock deviation, the local time must be synchronized with the real UTC time. Depending on the synchronization source (automatic or manual synchronization), the deviation is limited within certain limits:

### Manual clock adjustment

If there is a small difference between the actual UTC time and the UTC time displayed on the projector and you cannot connect to a Network Time Protocol server (NTP server), you can use manual synchronization (reference 6) instead. Using this method, you can enter an offset value between -360 and +360 seconds (reference 7).

A maximum offset of 360 seconds (6 minutes) per calendar year can be used using this method.

### Automatic clock adjustment (NTP server)

If you have access to a Network Time Protocol Server (NTP), it is recommended to synchronize the projector to it. Using this method, the internal clock of the projector will be continuously synchronized with the NTP server. Any deviation between the NTP server and the projector will be in the order of milliseconds.

**i** **NTP**  
Network Time Protocol

## 7.9.2 Setting the internal clock of the projector

### Location & access

Menu: Configuration > Projector > Internal clock settings

Level: Administrator, Service technician

## How to set the internal clock of the projector?

1. While in *Configuration > Projector > Internal clock settings*, set your local Time zone (reference 1). Click on the drop down box and select the applicable time zone for your location (reference 2).

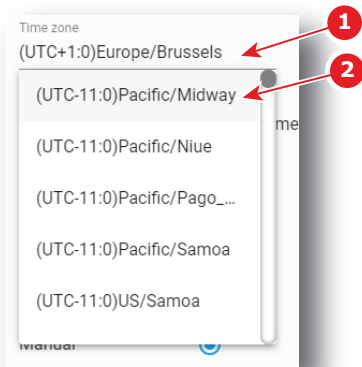

Image 7-168

2. Optionally, you can deactivate the *Automatic Daylight Saving Time (DST)* by deselecting the checkbox next to it (reference 3). If deselected, you can select the corresponding value for your time zone by using the associated drop box (reference 4).

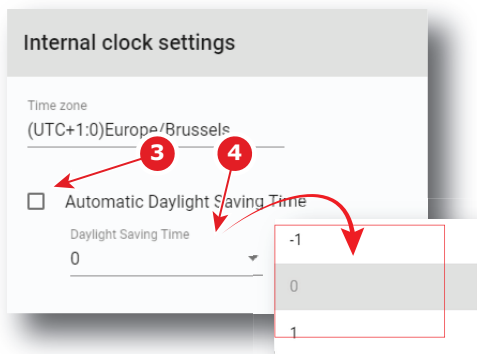



Image 7-169

 **Note:** Automatic Daylight Saving Time (DST) is by active by default. While you can disable this feature to adjust it manually, this is not recommended. Only disable this feature if you live in a time zone without an active DST, or if local legislation forces you to do so.

3. If you cannot access an NTP server, select **Manual** Synchronization (reference 5). If so, enter any observed adjustment necessary between the projector clock and the actual UTC time (reference 6) in seconds.

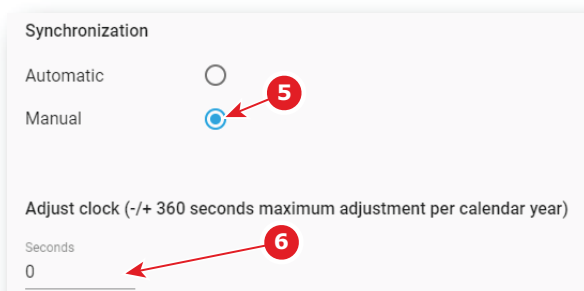



Image 7-170

 **Note:** Take into account that you can adjust a maximum of 360 seconds (either positive or negative) per calendar year.

4. If you can access an NTP server, select Automatic Synchronization (reference 7).
5. If Automatic is chosen, select the applicable NTP Server from the list of servers (reference 8).

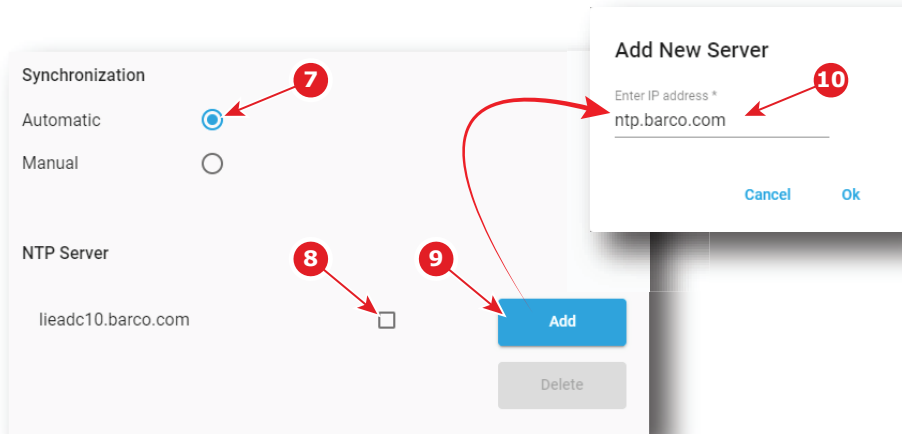



Image 7–171

 **Note:** If no NTP server has been entered before, you can Add a New Server (reference 9). Using this method, you can enter a valid IP address or server name (reference 10). The IP address or server name can be an internal or an external location, but it must be accessible via the network the projector is connected to. Confirm with **OK** to see the newly added server added in the list of NTP servers.

6. Click the **Save** icon to set the new time as current time.

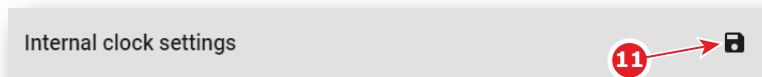

Image 7–172

## 7.10 Image Orientation

### 7.10.1 Changing image orientation

#### Location & access

Menu: Configuration > Projector > Internal clock settings

Level: Administrator, Service technician

#### What is possible?

The way of physical installation of the projector has an impact on displayed image. For example, rear or ceiling installation are possible. This menu allows to apply horizontal and/or vertical symmetry to the image.

## Menu overview

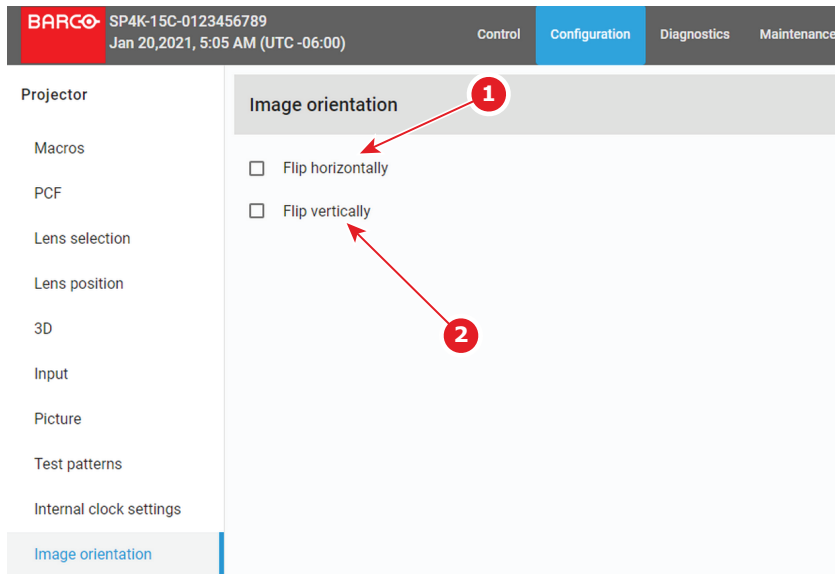

Image 7–173

Following actions are available in this menu:

- **Flip horizontally** (reference 1) allows to apply or release horizontal symmetry to the image.
- **Flip vertically** (reference 2) allows to apply or release vertical symmetry to the image.

These transformations (horizontal and vertical) can be apply simultaneously and/or independently.

### How to change image orientation

1. While in *Configuration > Projector > Image orientation*, change image orientation.  
 Select (or unselect) the checkbox *Flip horizontally* to apply (or release) horizontal symmetry to the image.  
 And/Or,  
 Select (or unselect) the checkbox *Flip vertically* to apply (or release) vertical symmetry to the image.



# Configuration - Light output

# 8

8.1	Light sensor calibration (LSC).....	192
8.2	Light output mode.....	197

## About this menu

Light output menu allows you to manage the desired light output and manage Light Sensor Calibration (LSC) files.

## 8.1 Light sensor calibration (LSC)



### LSC file

Light sensor calibration file

### 8.1.1 About light sensor calibration

#### Location & access

Menu: Configuration > Light output > Sensor

Level: Administrator, Service technician

#### What should be done?

The built in light sensor of the projector should be calibrated before the measured light output is the correct value. The calibration depends on the screen type and the projected image format (flat or scope). Before the measured light out is correct, at least 2 calibration files should be created: one for flat and another one for scope.

#### Overview

This panel allows to manage calibration files in order to realize the light sensor calibration.

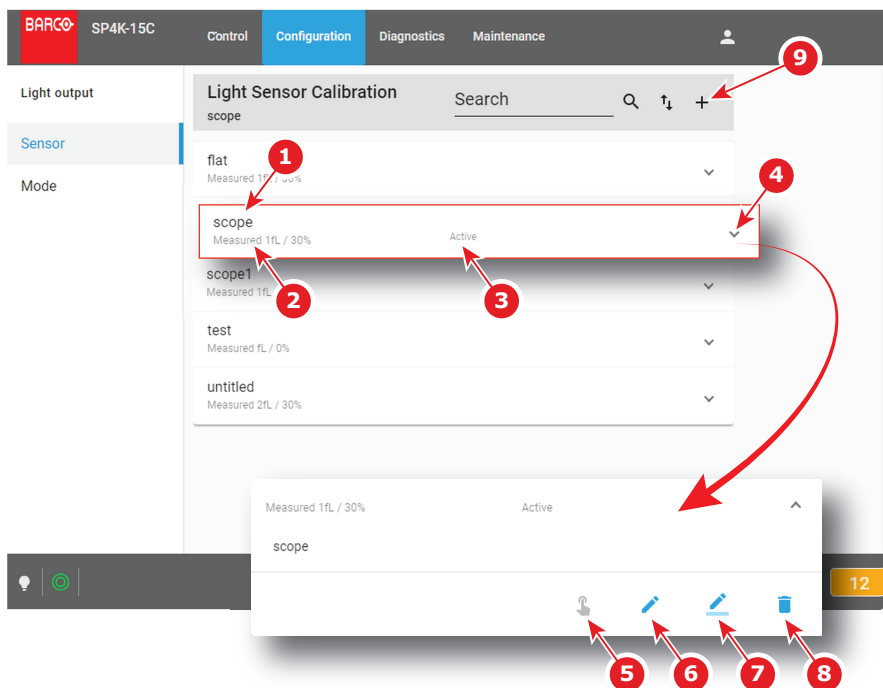

Image 8-1

Each sensor calibration file displayed in the list has a name (reference 1). Power value (reference 2) already defined for this file is shown just under this name. When a calibration file is activated the status (reference 3) turns to *Active* and its name is noticed on top of the list.

Click on sensor calibration file (reference 4) in the list allows to show it in its expanded form and displays a contextual menu.

Following actions are available in this menu:

- **Activate** (reference 5) allows to calibrate the light output with the values defined in the sensor calibration file.
- **Edit** (reference 6) allows to modify the sensor calibration file power values.
- **Rename** (reference 7) allows to change the name of the sensor calibration file.
- **Delete** (reference 8) allows to remove the sensor calibration file.



Click **Plus** (reference 9) allows to create a new sensor calibration file.

## 8.1.2 Creating a new light sensor calibration file



Power settings are temporarily overruled with values in edit/creation mode. Exiting this page will restore the initial settings.

### Required tools

Spectroradiometer

### Prerequisites

1. Place a spectroradiometer in the auditorium. Position it in such a way it meets the following requirements.
  - Perpendicular to the screen.
  - In the auditorium sweet spot.
  - In such a way it can measure the reflected light from the center of the screen.
2. Set up the ambient light conditions as it should be during the play-out of the movie (e.g. only the stairs and emergency exit lighting are switched on).
3. Project a full white test pattern with the desired aspect ratio (flat or scope).

### How to create a light sensor calibration file

1. Click on the **New** icon, located on top of the list.

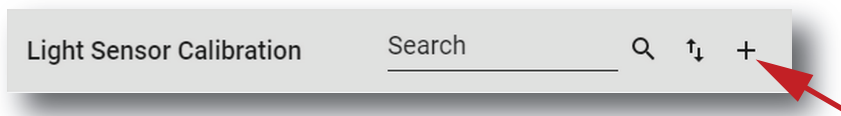

Image 8–2

A window is displayed with a new (untitled) calibration file.

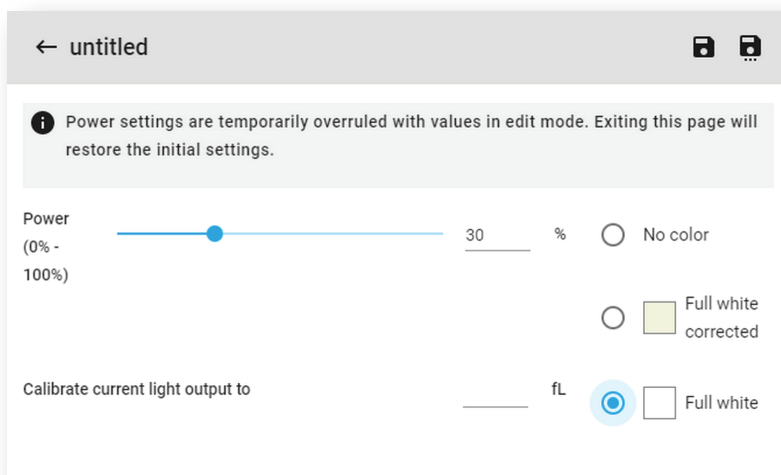



Image 8–3

2. If it is not already done Select a **Test pattern** in the list to display a test pattern on screen.
3. Measure the current light output with the spectroradiometer. The default target value is 14 foot Lambert (fL).
4. Adjust the **Power** slider until the spectroradiometer measures the target value. Several iterations will be necessary.

 **Note:** When using CLO it can be possible that due to the aging process the desired 14 fL cannot be reached.

5. Enter the measured value (14 fL) into the field **Calibrate current light output to**.
6. Click **Save** or **Save As** (reference 3) to display the *Save As* window. Enter a recognizable name (reference 4) and confirm with **Save** (reference 5).

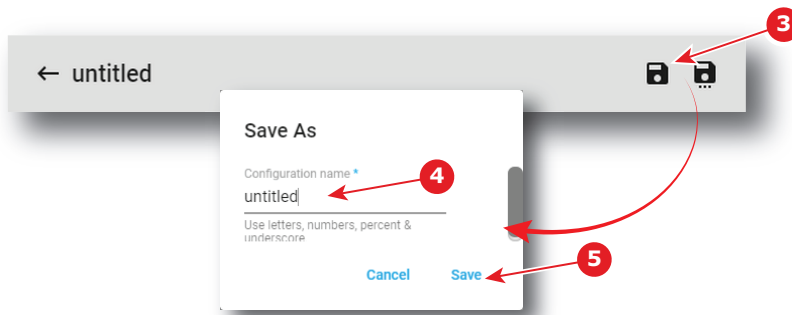

Image 8–4

7. The new file is ready to be used as light sensor calibration file (LSC file). See [“Activating a light sensor calibration file”](#), page 194 to activate this file.
8. Repeat this procedure for every desired aspect ratio and format (e.g. flat and scope). Save each iteration under a different file.

### 8.1.3 Activating a light sensor calibration file

#### How to activate a light sensor calibration file

1. While in the *Light Output Sensor* menu, select the light sensor calibration file that matches the screen type and the desired projected image format.

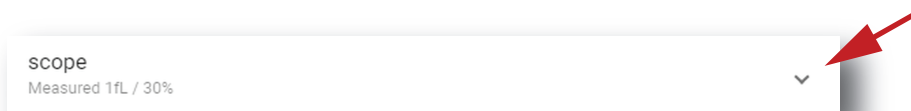

Image 8–5

The calibration file is displayed in its expanded form with menu.

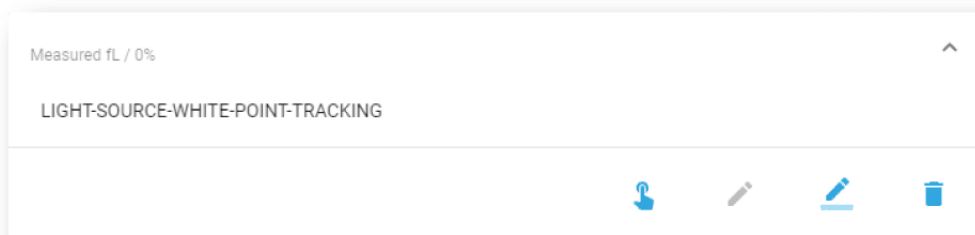

Image 8–6

2. Click the **Activate** icon. 

The calibration file is now activated :

- Built-in light sensor of the projector is settled with parameters defined in the calibration file.
- Name of the calibration file is now active (reference 2) and is displayed at the top of the LSC file list (reference 1).

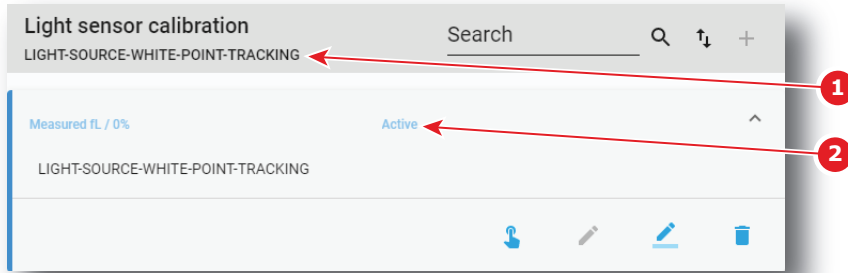

Image 8–7 LSC file is activated

## 8.1.4 Deleting a light sensor calibration file

### How to delete a light sensor calibration file

1. In the Light sensor Calibration menu, select the undesired light sensor calibration file.

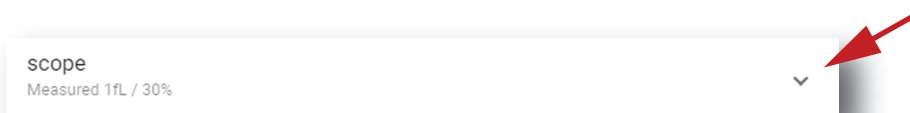

Image 8–8

The calibration file is displayed in its expanded form with menu.

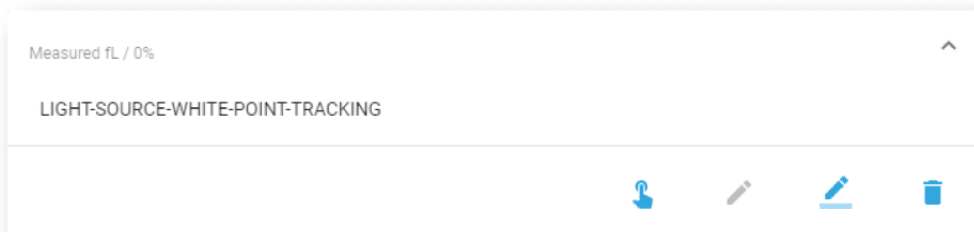

Image 8–9

2. Click the **Delete** icon in the menu and confirm with **OK**.



The calibration file is removed from the list

## 8.1.5 Editing a light sensor calibration file



If you want to edit an LSC file, make sure you comply to the same prerequisites as when creating this LSC file. For more info, refer to [“Creating a new light sensor calibration file”, page 193](#).  
If you only want to rename the LSC file, see the following procedure instead: [“Renaming a light sensor calibration file”, page 196](#).

### How to edit a light sensor calibration file

1. In the Light Sensor Calibration menu, select the desired LSC file.



Image 8–10

The calibration file is displayed in its expanded form with menu.

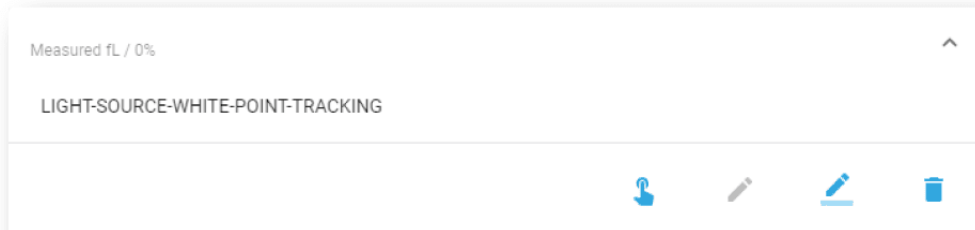



Image 8–11

2. Click the **Edit** icon.  *Edit* window is displayed.

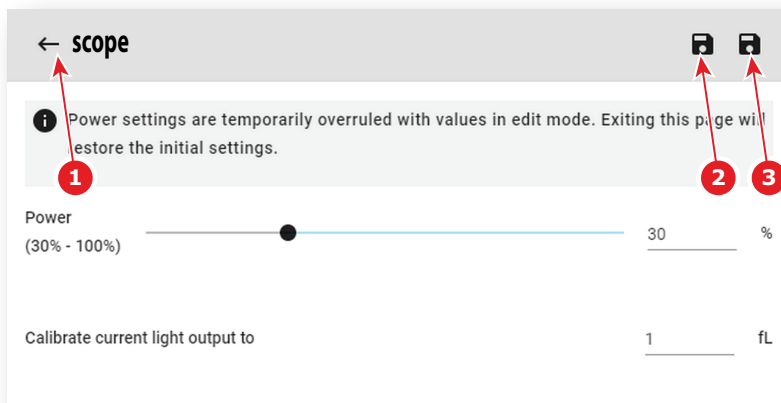



Image 8–12

3. edit the desired values.  
 *Note:* Please refer to section “[Creating a new light sensor calibration file](#)”, page 193 to correctly modify a light sensor calibration file parameters.
4. Click **Save** (reference 2) to save all modifications under the same name.  
or  
Click **Save as** (reference 3) to save the current modifications under a different name.

## 8.1.6 Renaming a light sensor calibration file

### How to change the name of a light sensor calibration file

1. In the Light sensor calibration menu, click on the desired LSC file.



Image 8–13

The calibration file is displayed in its expanded form with menu.

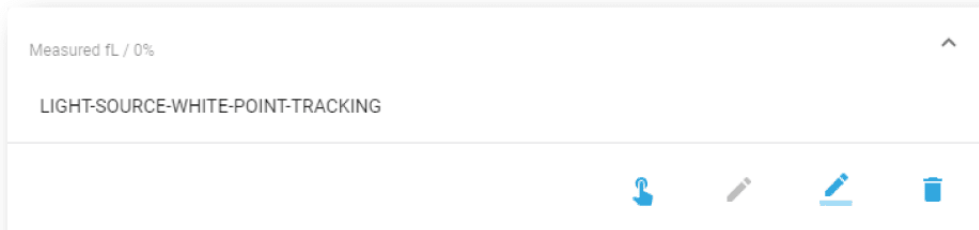



Image 8–14

2. Click **Rename** in the menu. 
- The *Rename* dialog is prompted.

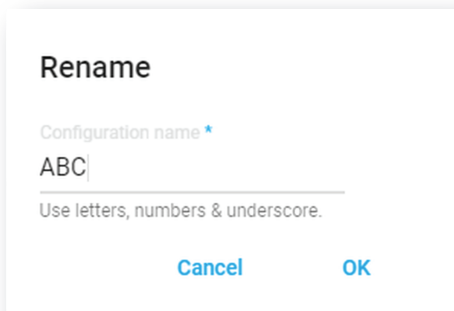

Image 8–15

3. Enter a new *file name* and click **OK**.

## 8.2 Light output mode

### Location & access

Menu: Configuration > Light output > Mode

Level: Administrator, Service technician

### Overview

This menu allows to choose the light output mode.

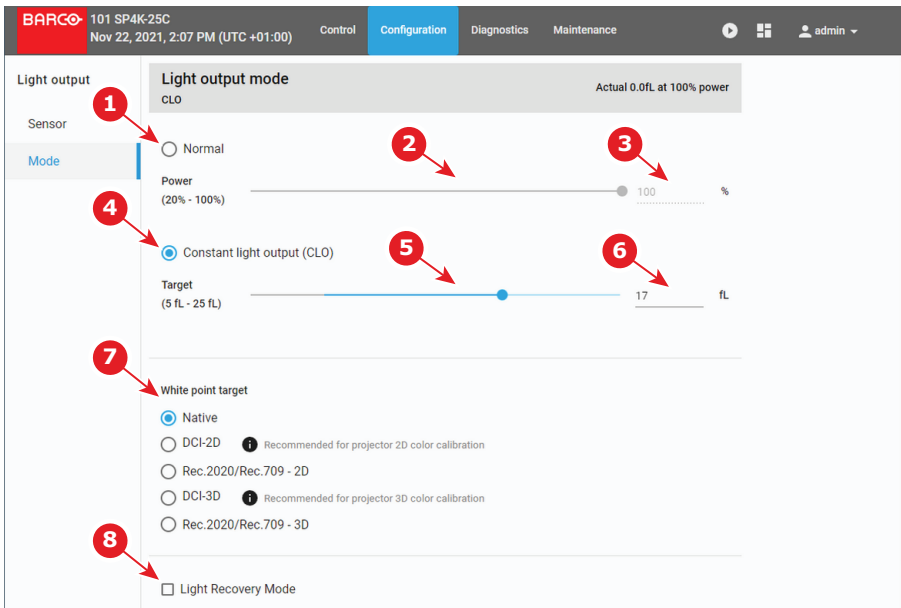

Image 8–16

Selecting **Normal mode** (reference 1) means that the light source will operate at the designated power level (no power adaptation to meet constant light output). You can change the power level by dragging the slider (reference 2) or manually entering the power value (in %) (reference 3).

Selecting **CLO mode** (reference 4) forces a constant light output of the projector over a certain period. This will eliminate uncontrolled light output drop caused by natural aging of the light source. The light output is checked every 5 minutes, if the target is not met, the laser power is adjusted. You can change the target light output by dragging the slider (reference 5) or manually entering the power value (in foot-Lambert) (reference 6).

Next to the light output mode, you can also select the desired **White Point Target** (reference 7). While technically the native white point should be correct, it may vary slightly from the DCI specifications or to the REC 2020 space color specifications. If this happens, the option is available to adjust the white point to the chosen standard.

You can choose between the following calibration files:

- Native white point calibration.
- DCI-2D (Recommended for 2D color calibration)
- Rec.2020 and Rec.709 - 2D
- DCI-3D (Recommended for 3D color calibration)
- Rec.2020 and Rec.709 - 3D

Also available, on the bottom of this menu, there is the option to enable **Light Recovery Mode** (reference 8). When the projector is connected to a UPS and this option is selected, the light will recover to its original state after a power failure lasting longer than 5 seconds.

## How to set up the light output

1. In the Light output Mode menu, select *Normal* (reference 1).

*Normal* mode parameters are now available (references 2 & 3), and *CLO* mode parameters are greyed out (not accessible).



Image 8–17

or

select the radio button *Constant light output (CLO)* (reference 4).

*CLO* parameters are now available (references 5 & 6), and *Normal* mode parameters are greyed out (not accessible).

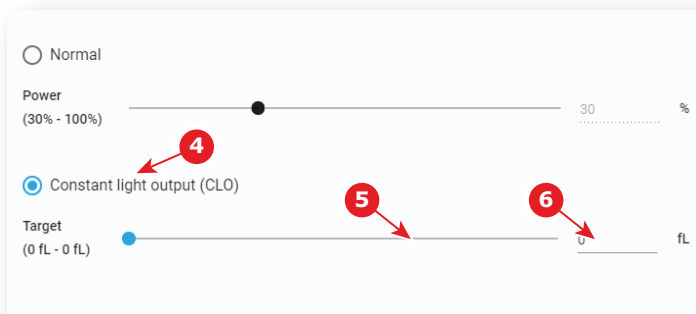

Image 8–18

2. Then, set the light output, settings depending the selected mode:
  - *Normal* mode: a light source dimming value can be set with the slider (reference 2) or directly in the input box (reference 3).
  - *CLO* mode: a desired constant light output value (in fL) can be set with the slider (reference 5) or directly in the input box (reference 6).
3. Choose the target white point of the projector (reference 7) either to the desired projection spec, or keep the Native white point.

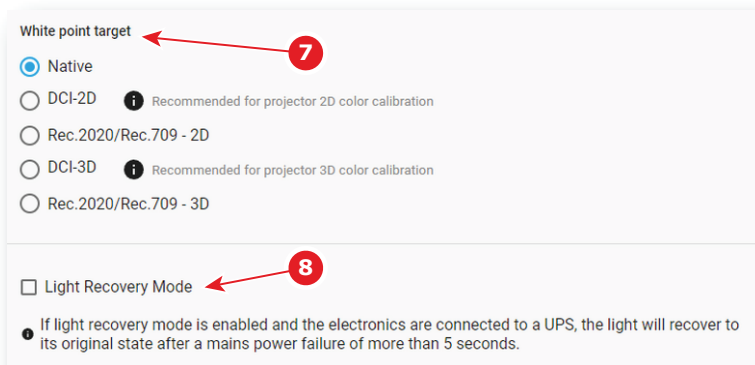

Image 8–19

4. If your projector is set up with a UPS, you can also activate Light Recovery Mode (reference 8).





# Configuration - Color calibration

# 9

9.1	Calibration process overview .....	202
9.2	Light source – White Point calibration .....	202
9.3	Projector color .....	207
9.4	Verifying the colors after correction .....	211
9.5	Spatial color calibration .....	214

## About this menu

Color calibration has to be done for each projector laser mode and aspect ratio and starts with the white point calibration.

During this white point calibration, the color coordinates are measured and uploaded. At the same time the option exists to save these coordinates can be saved in an MCGD file.

When saving the coordinates in an MCGD file, the color gamut calibration can be skipped. When the coordinates are not saved, then you have to proceed with color gamut calibration.

These procedures for 2D and 3D are equal for all projectors.

## 9.1 Calibration process overview

### Process overview

1. Create **Lens position files for FLAT and SCOPE**. For more on creating lens files, see [“Creating a lens position file”](#), page 119.
2. If applicable for your projector: **create the necessary amount of 3D files**. For more info on creating 3D files, see [“3D”](#), page 127.
3. Calibrate the light source, using **white point calibration**. For more info, see also [“Light source – White Point calibration”](#), page 202.
4. For the light sensor calibration, select the desired aspect ratio by activating the correct lens file.
  - **SCOPE** format
  - **FLAT** format
5. **Perform Light sensor calibration and create LSC files for Flat, Scope and 3D** (if applicable for your projector). For more info, see [“Light sensor calibration \(LSC\)”](#), page 192.
6. Prepare for color calibration in 2D. Set up the correct LSC file and the desired white point target. For more info on setting white point target, see [“Light output mode”](#), page 197.
7. **Color gamut calibration** (electronic P7 correction). Measured values are saved in the **Measured Color Gamut Data (MCGD) file**. This calibration needs to be repeated for each used format (FLAT/SCOPE) and for each used projection mode (2D/3D).

For more info about MCGD files and color gamut calibration, see [“Projector color”](#), page 207.

8. **Verify the corrected colors by comparing to select target colors**. The target colors are stored in **Target Color Gamut Data (TCGD) files**. Several TCGD files are already available in the file system of the projector.

For more info about TCGD files and verifying colors, see [“Verifying the colors after correction”](#), page 211.

9. **Arrange calibration files in a macro**. To apply correct color calibration it is important that the MCGD file (s) and matching TCGD file(s) are activated after that the INPUT file and PCF file are activated. For that it is recommended to create a macro where the files are loaded one by one in the right order:
  1. First activate the **INPUT** file.
  2. then activate the **PCF** file (PCF already contains plane 1 information),
  3. then activate the **MCGD** and **TCGD** files.

For more details on creating macros, see [“Macros control”](#), page 70.

## 9.2 Light source – White Point calibration

### 9.2.1 About the light source white point calibration menu

#### Location & access

Menu: Configuration > Color calibration > Light source

Level: Administrator, Service technician

#### About white point calibration

The projector uncorrected white point ( $W_n$ ) has to be shifted towards the DCI white point ( $W_t$ ). The coordinates of the DCI white point ( $x_w=0.314$  ;  $y_w=0.351$ ) are embedded in the projector software and cannot be changed. The coordinates of the projector uncorrected white point has to be measured and entered.

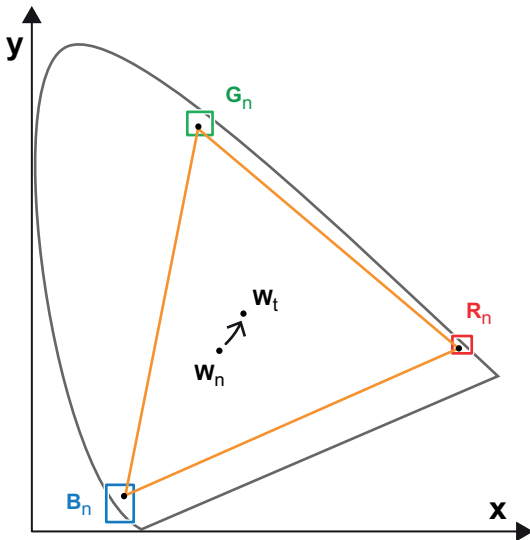

Image 9-1 Shifting projector 'white point' towards desired white point (laser power calibration)

The projector uncorrected white point can be defined by measuring the xy coordinates of the uncorrected primary colors (red, green, blue) and uncorrected full white separately.

The initial set of xy values stored in the projector for the uncorrected white point are the same as for DCI white point. After white point calibration, the initial values are overwritten with the measured values.

Based on the measured values the projector can balance the Red, Green, and Blue light to move the projector uncorrected white point towards the desired white point. This adjustment is called 'Laser RGB correction' or "Light Source calibration".

The projector uncorrected white point is different for 2D projection and 3D projection. Therefore, the projector uncorrected white point has to be measured and entered for each projection mode separately. Per projection mode one set of measured values are stored. Depending on the projection mode, the corresponding set is used for white point correction.

In case of 3D projection, the xy coordinates of uncorrected white has to be measured for each 3D file separately.

## Overview

This menu allows you to perform a white point calibration.

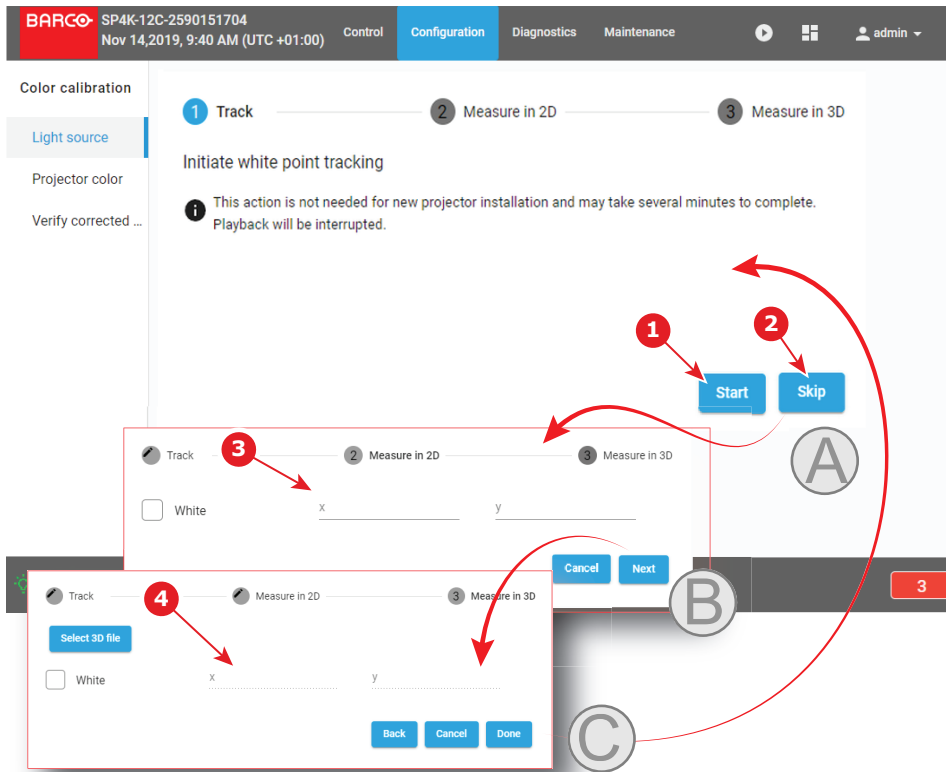

Image 9–2 White point calibration menu

Clicking on **Start** (reference 1) will start a new white point tracking procedure. By clicking **Skip** (reference 2) you will be able to enter successively the point coordinates for 2D (reference 3) and for 3D (reference 4).

Lower part of this menu is dedicated to display of the results.

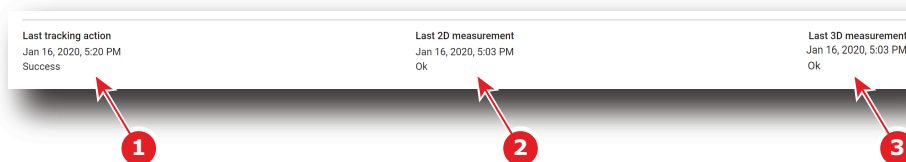

Image 9–3

If a previous white point tracking procedure has been done, results and status for each step are displayed here:

- Left column (reference 1) indicates the date and status of the last white point tracking.
- Middle column (reference 2) indicates if the 2D measurement was done and at which date.
- If 3D projection is required, the right column (reference 3) indicates if the 3D measurement was done and at which date.

## 9.2.2 White point calibration

### Location & access

Menu: Configuration > Color calibration > Light source

Level: Administrator, Service technician

### Required tools

Spectroradiometer

## Preparations

- Place a spectroradiometer in the auditorium. Position it in such a way it meets the following requirements.
  - Perpendicular to the screen.
  - In the auditorium sweet spot.
  - In such a way it can measure the reflected light from the center of the screen.
- Set up the ambient light conditions as it should be during the play-out of the movie (e.g. only the stairs and emergency exit lighting are switched on).
- Project a full white test pattern with the desired aspect ratio (flat or scope).

## How to calibrate

- In the Light Source menu, perform White Point tracking. To do so, click **Start** (reference 1) to do so.

 **Note:** This action may take several minutes to complete. Playback will be interrupted.

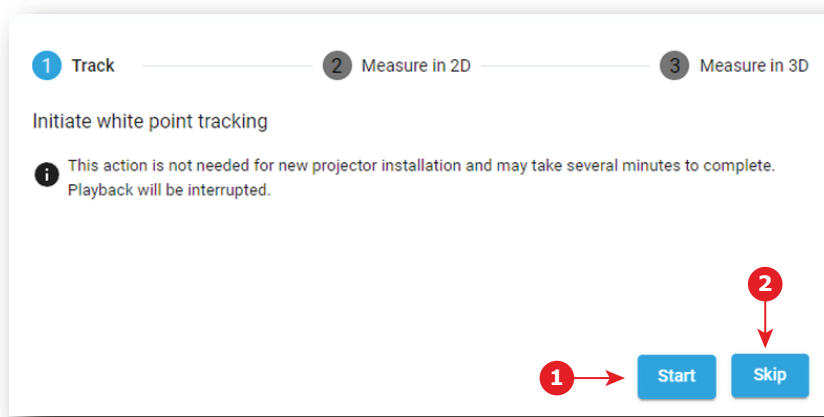

Image 9–4 White Point Calibration – White Point Tracking

The laser white point calibration will be reset. The default settings are programmed.

- Click **Skip** (reference 2) to access the 2D measurement.

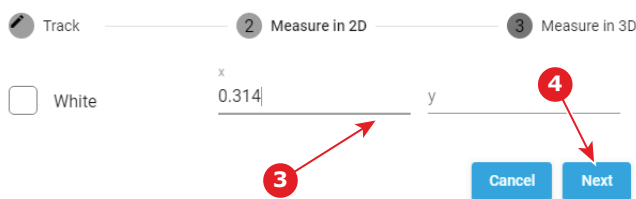

Image 9–5 White Point calibration - 2D measurement

- Measure the white coordinates (x, y) with spectrometer and enter in the x and y fields respectively (reference 3).
- If 3D projection is required, click **Next** (reference 4) to access the 3D measurement. If not, press **cancel** to exit.

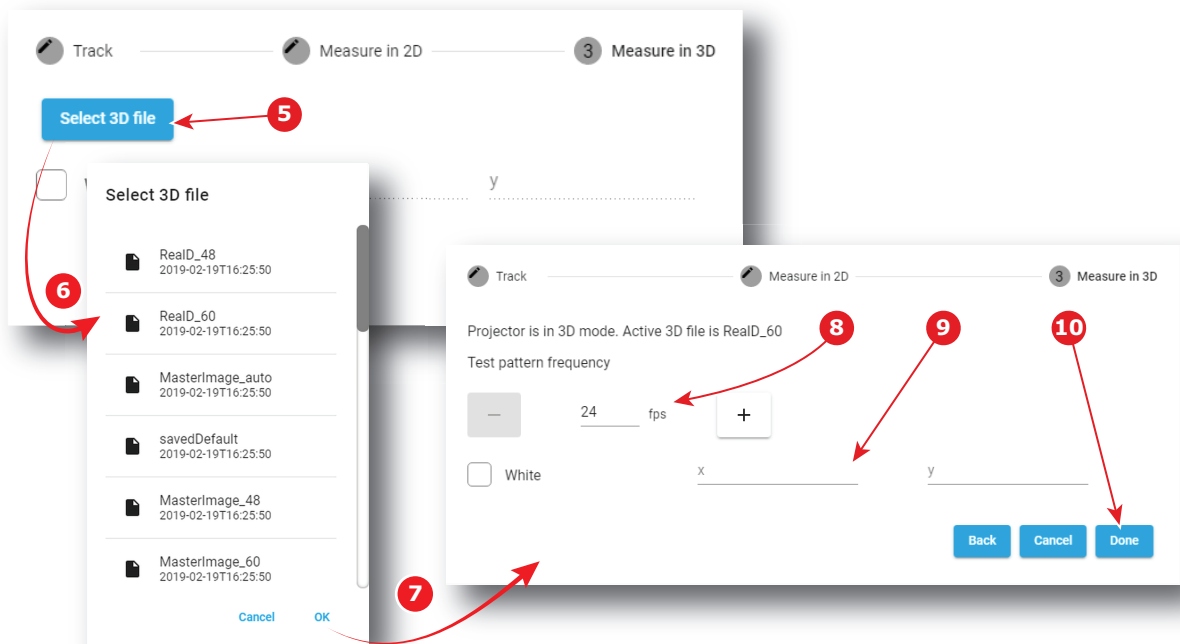

Image 9–6 White Point Calibration – 3D Measurement

5. Click **Select 3D file** (reference 5).
6. Select the desired 3D file from the prompted list (reference 6) and confirm with OK (reference 7).  
The selected 3D file is implemented in the menu, alongside a *test pattern frequency* slider (reference 8) .
7. Enter the desired frequency in frames per second (fps), or use the + and - keys to change the frequency..
8. Measure the white coordinates (x, y) with spectrometer and enter in the wizard (reference 9).
9. Click **Done** (reference 10) to complete the wizard.  
A window allowing to choose one of the recently updated calibration files is displayed.
10. Select a new calibration file (e.g. 2D or 3D) according to the type of MCGD you want to adjust in the next steps, then click **OK** to activate it.

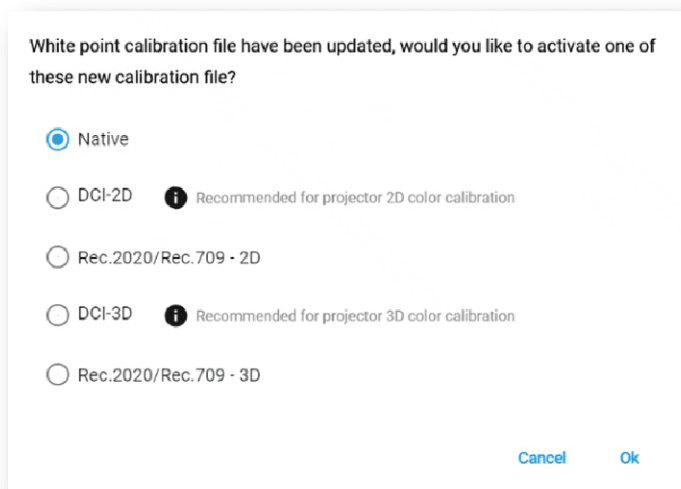

Image 9–7

or

Click **Cancel** to close the window without modifying the calibration file currently selected.

## 9.3 Projector color

### 9.3.1 About Color calibration

#### Location & access

Menu: Configuration > Color Calibration > Projector Color

Level: Administrator, Service technician

#### About MCGD files

MCGD files contain the measured color gamut data (color reference values) for a specific projector installation. This type of file can be created in the Projector Color menu.

#### Overview

The following menu displays the list of MCGD files and allows you to create and manage new MCGD files.

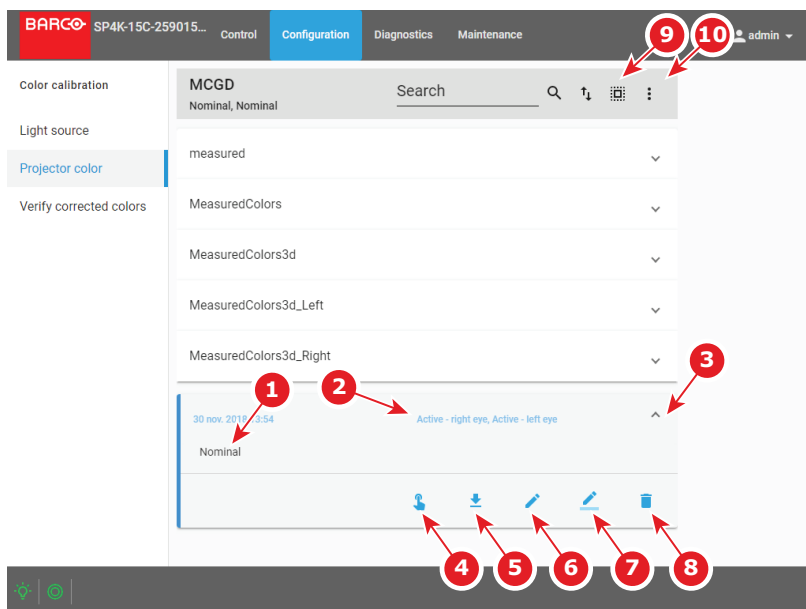

Image 9–8 Projector Color menu

Each MCGD file displayed here has a name (reference 1) and a status (reference 2).

An **expand** button (reference 3) is located to the right of each MCGD file if it has been activated. This button shows the MCGD file in its expanded form and displays a list of actions.

- **Activate** (reference 4): Activates the current MCGD file.
- **Export** (reference 5): Allows you to download the selected MCGD file.
- **Edit** (reference 6): Allows you to edit the selected MCGD file.
- **Rename** (reference 7): Allows you to rename the selected MCGD file.
- **Delete** (reference 8): Deletes the selected MCGD file, after confirmation.

In the menu bar, there is an option to **select all MCGD files** (reference 9) and a **menu** (reference 10), with the following possible actions.

- **New**: Creates a new MCGD file.
- **Import**: Imports a previously downloaded MCGD file.
- **Export**: Exports the currently selected MCGD file(s).
- **Delete**: Allows to remove several MCGD files selected in the list.

## 9.3.2 Creating a new MCGD file

### Required tools

Photospectrometer

### How to measure

- In the MCGD menu, create a new **MCGD file**. To do so, select the **Menu** button and click **New**.  
A new untitled MCGD is displayed, with the following active projector settings displayed:
  - Projector mode (2D/3D)
  - The desired white point target.
  - The current Light output mode

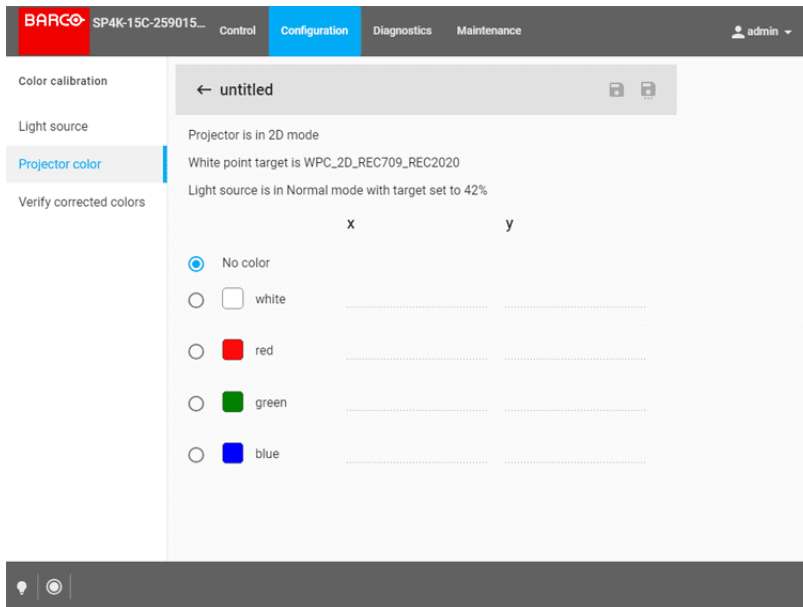

Image 9-9 Creating a new MCGD file

- Select the desired color (e.g. white).
- Measure the color coordinates for that specific color and enter the x and y coordinates in the appropriate fields.
- Repeat this procedure for all other colors.
- Click **Save** or **Save as** to save the MCGD file.

## 9.3.3 Editing an active MCGD file

### Required tools

Photospectrometer

### How to edit

- In the MCGD menu, select one of the active MCGD files and click **Edit**.

 *Note:* You can only edit an active MCGD file.

The edit window is displayed.



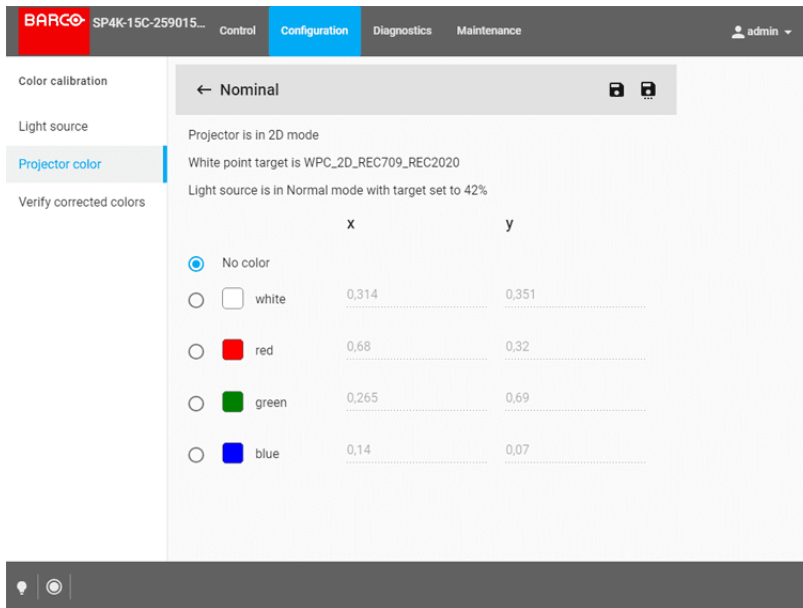

Image 9–10 Example of editing an MCGD file

2. Select the desired color (e.g. white).
3. Measure the color coordinates for that specific color and enter the x and y coordinates in the appropriate fields.
4. Repeat this procedure for all other colors.
5. Click **Save** to save the current MCGD file.

or

click **Save as** to save the MCGD file under a new name.

### 9.3.4 Exporting and importing MCGD files

#### How to export a single MCGD file

1. In the MCGD menu, select the desired MCGD file and click the **download** icon.
2. Save the MCGD file as a .tar file on your device.

#### How to export multiple or all MCGD files

1. In the MCGD menu, click the **Select all MCGD files** icon.  
All MCGD files are selected, and selection boxes will become visible.

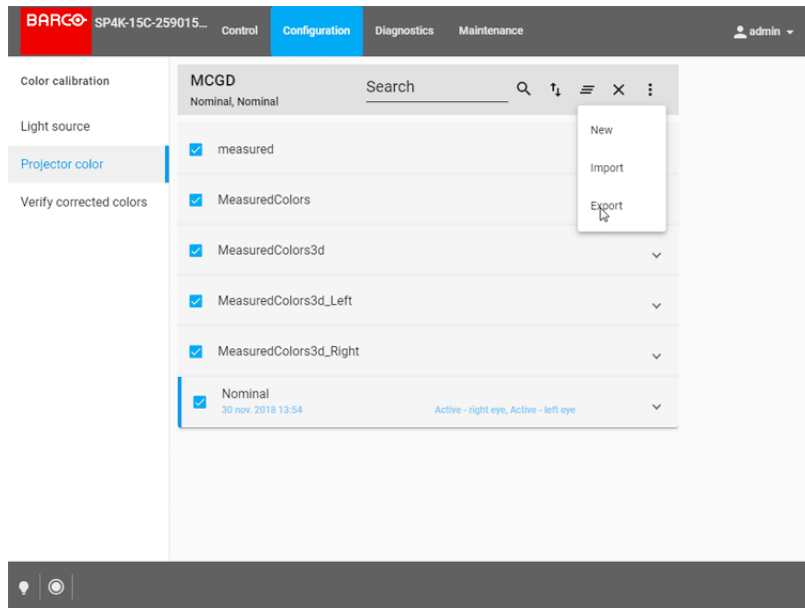

Image 9–11 Example of all MCGD files being selected.

2. If there are any undesired TCGD files selected, deselect the undesired file.
3. In the menu, click **export**.
4. Save the MCGD files as a combined .tar file.

### Importing MCGD files

1. In the MCGD menu, click **Import**.
2. Browse to the desired file in .tar format and confirm.

If the MCGD files are supported by this projector, they will be included in the MCGD files list.



If a file has the same name as a file already present, a confirmation will be required before overwriting.

## 9.3.5 Deleting several MCGD files

### What is possible

Several MCGD files could be deleted in a single action.

### Location & access

Menu: Configuration > Color Calibration > Projector Color

Level: Administrator, Service technician

### How to delete several MCGD files

1. While in *Configuration > Color Calibration > Projector Color*, click **Select All** (reference 1) and use the check boxes (reference 2) located at right of the MCGD files in order to select/deselect the files you want to delete.

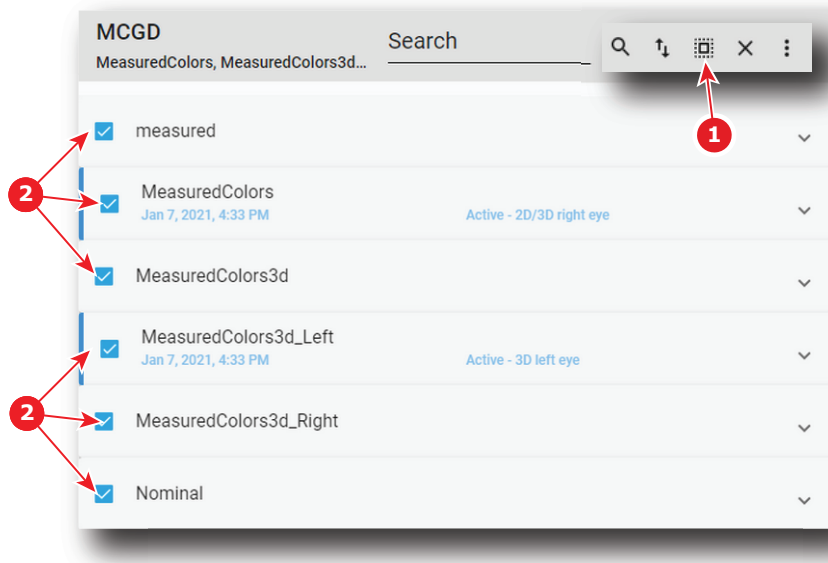

Image 9–12

2. Click on the macro general menu located on the top right of the list, then select **Delete** and confirm with **OK**.

The macro files selected are definitively removed from the list.

## 9.4 Verifying the colors after correction

### Location & access

Menu: Configuration > Color Calibration > Verify Corrected Colors

Level: Administrator, Service technician

### Overview

This panel allows you to compare the corrected colors after calibrations to certain color standards (e.g. Rec. 2020, SMPTE C, etc)..

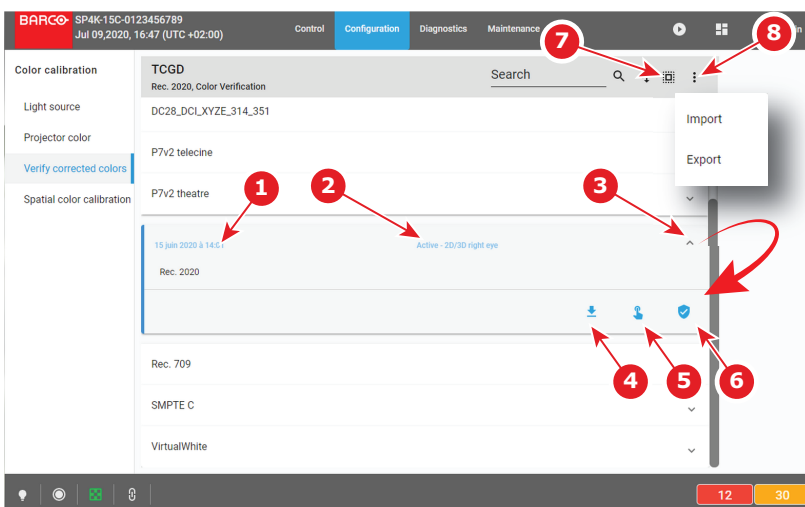

Image 9–13 Verify corrected colors menu

Each TCGD file displayed here has a name (reference 1) and a status (reference 2).

An **expand** button (reference 3) is located to the right of each TCGD file. This button shows the TCGD file in its expanded form and displays a list of actions:

- **Export** (reference 4): copies the TCGD file in the *Downloads* directory of your computer (e.g. DC28\_DCI\_Laser.TCGD).
- **Activate** (reference 5): Activates the current TCGD file.

If the TCGD file has been activated, a supplemental action is available:

- **Verify** (reference 6): allows to compare the corrected colors after calibrations to color standards present in the TCGD file.

In the menu bar, there is an option to **select all TCGD files** (reference 7) and a **menu** (reference 8), with the following possible actions.

- **Import**: allows to import a TCGD file alone (one single file), or a package of TCGD (.tar) with several files inside.
- **Export**: creates a downloadable backup package (.tar) that contains all TCGD selected in the list, then copies this package in the *Downloads* directory of your computer.

## How to verify

1. In the TCGD menu, click on the activate icon of the desired TCGD file (reference 5) you want to compare



The Activate TCGD dialog is prompted.

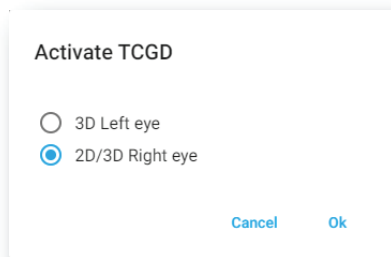

Image 9–14

2. Confirm for which format (2D/3D) you want to activate the TCGD. In case of 3D, also choose which eye (left/right).



*Tip:* If both eyes are required in 3D, activate the same file a second time and select the other eye.

3. Once activated, click on the expand button of the desired TCGD file (reference 3) and on the verify button (reference 6).

The detail window of the TCGD file is displayed.

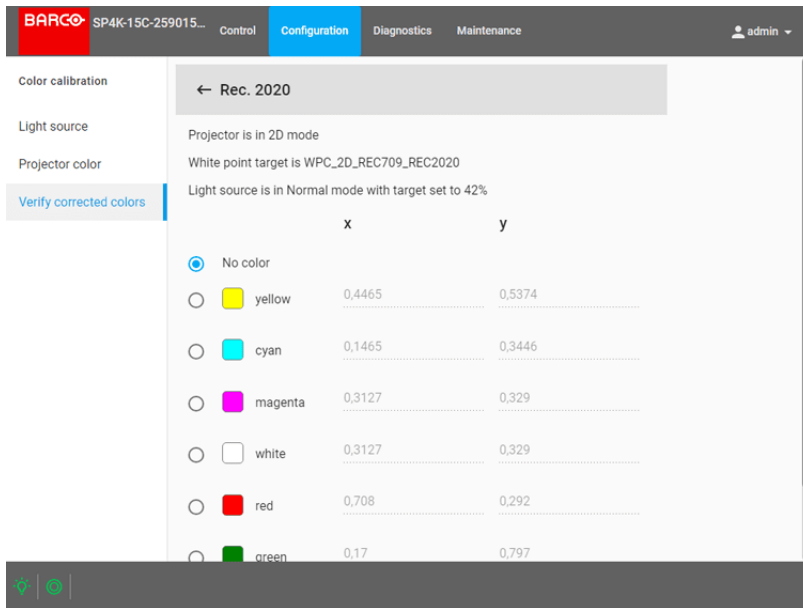

Image 9–15 Example of a detail window of a TCGD file

4. Select the desired color to compare.  
The selected color is displayed on the screen **with color correction**.
5. Measure the coordinates with a colorimeter on the screen and check with the values next to the selected color.
6. Repeat this procedure for every other color in this TCGD file.

### How to export a single TCGD file

1. In the TCGD menu, click on the desired TCGD file.  
The TCGD file is displayed in its expanded form with menu.

2. Click the **Export** icon. 

A TCGD file (.TCGD) is created and automatically copied in the *Downloads* directory of your computer (e. g. DC28\_DCI\_Laser.TCGD).

### How to export multiple or all TCGD files

1. In the TCGD menu, click the **Select all TCGD files** icon.  
All TCGD files are selected, and selection boxes will become visible.
2. If there are any undesired TCGD files selected, deselect the undesired file.
3. In the menu, click **Export**.  
All TCGD selected are combined in downloadable backup package (.tar), then this package is automatically copied in the *Downloads* directory of your computer.

### Importing TCGD files

1. In the TCGD menu, click **Import**.  
*Open* window is displayed.
2. Locate and select a TCGD file (file with .TCGD extension).  
or  
Locate and select a backup package (.tar) with several TCGD files inside.
3. Click **Open** (reference 4).

If selected files are supported by this projector, they will be included in the TCGD files list.

## 9.5 Spatial color calibration

### 9.5.1 About spatial color calibration

#### Location & access

Menu: Configuration > Color Calibration > Spatial color calibration

Level: Administrator, Service technician

#### About SCC files

SCC files contain color reference values for specific projector installation. These values are used to calculate correct compensation for white point variations over the width of the screen.

#### Overview

The following menu displays the list of SCC files and allows you to create, import, export and execute these files.

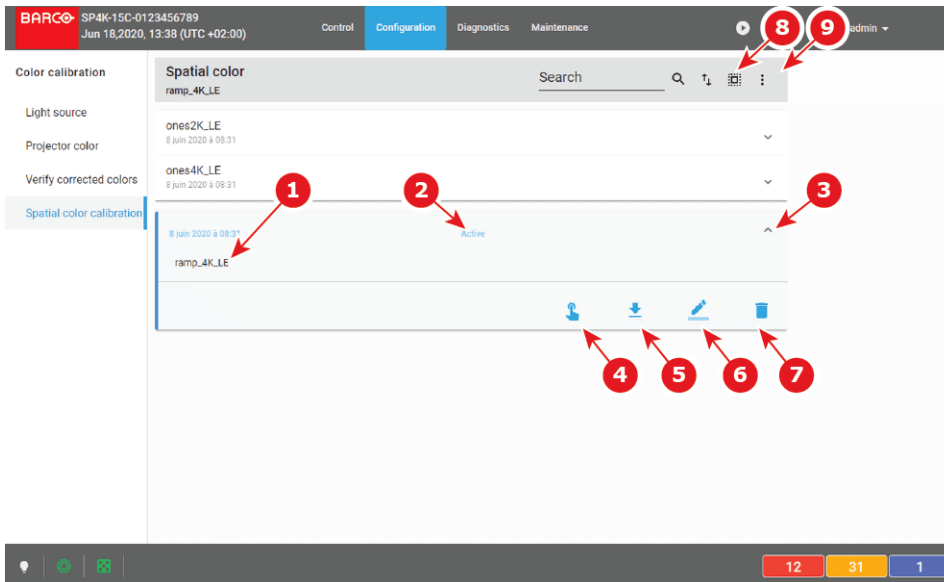

Image 9-16

Each SCC file displayed here has a name (reference 1) and a status (reference 2).

An **expand** button (reference 3) is located to the right of each SCC file. This button shows the SCC file in its expanded form and displays a list of actions.

- **Activate** (reference 4): Activates the current SCC file.
- **Export** (reference 5): copies the SCC file in the *Downloads* directory of your computer (e.g. ones2K\_LE.LUT-SCC).
- **Rename** (reference 6): Allows you to rename the selected SCC file.
- **Delete** (reference 7): Deletes the selected SCC file, after confirmation.

In the menu bar, there is an option to **select all SCC files** (reference 8) and a **menu** (reference 9), with the following possible actions.

- **New** allows to create a SCC file directly on the projector by following a 3 steps procedure (Colorimetry measurements are required during this procedure).
- **Import**: allows to import a SCC alone (one single file), or a package of SCC (.tar) with several files inside.
- **Export**: creates a downloadable backup package (.tar) that contains all SCC selected in the list, then copies this package in the *Downloads* directory of your computer.
- **Delete**: allows to remove several SCC files selected in the list.

## 9.5.2 Activating a SCC file

### How to activate a spatial color calibration file

1. In the spatial color Calibration menu, click on the desired SCC file.



Image 9–17

The spatial color calibration file is displayed in its expanded form with menu.

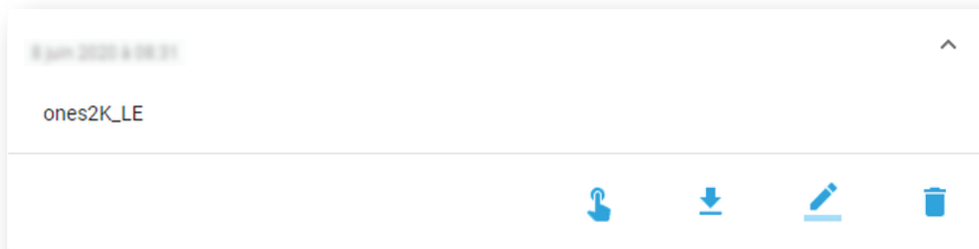

Image 9–18

2. Click the **Activate** icon. 

The calibration file is now activated :

- All previous uploaded SCC information is overwritten with parameters defined in the calibration file.
- Name of the spatial color calibration file is now active (reference 2) and is displayed at the top of the SCC file list (reference 1).

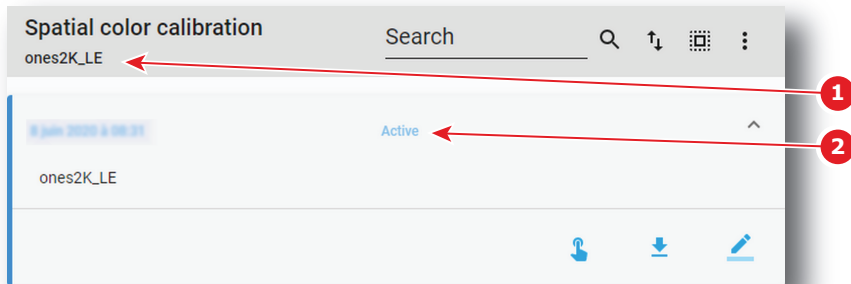

Image 9–19

## 9.5.3 Renaming a SCC file

### How to change the name of a spatial color calibration file

1. In the spatial color Calibration menu, click on the desired SCC file.

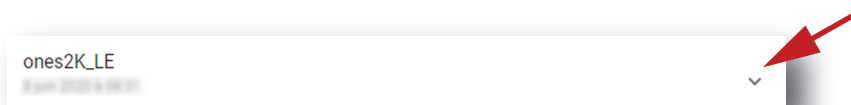

Image 9–20

The spatial color calibration file is displayed in its expanded form with menu.

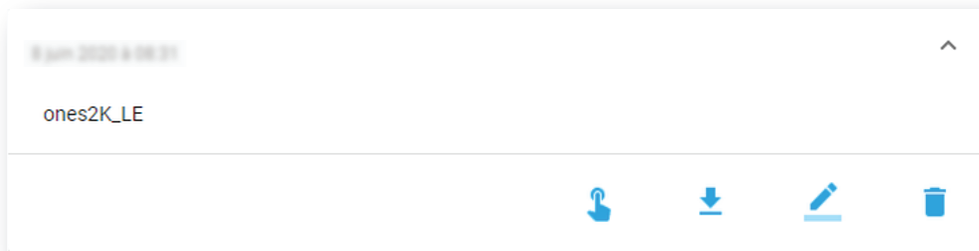



Image 9-21

2. Click **Rename** in the menu.   
The *Rename* dialog is prompted.

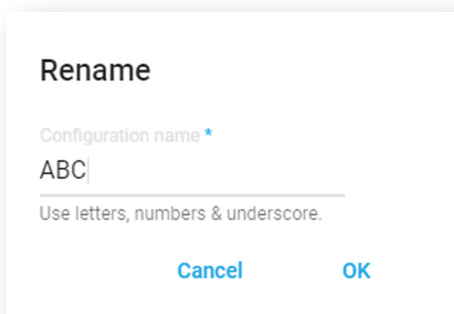

Image 9-22

3. Enter a new *file name* and click **OK**.

## 9.5.4 Deleting a SCC file

### How to delete a spatial color calibration file

1. In the spatial color Calibration menu, click on the desired SCC file.

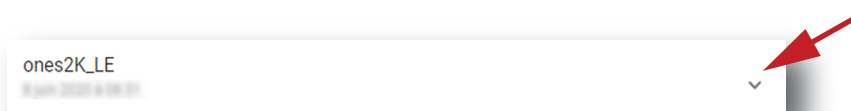

Image 9-23

The spatial color calibration file is displayed in its expanded form with menu.

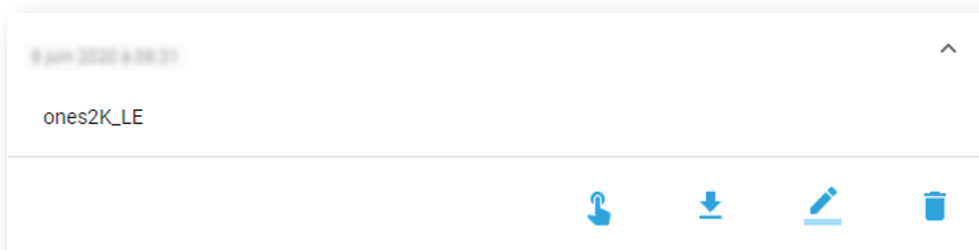



Image 9-24



- Click the **Delete** icon in the menu and confirm with **OK**.   
The spatial color calibration file is removed from the list

## 9.5.5 Creating a new SCC file

### Required tools

Photospectrometer

### How to measure

- In the Spatial color menu, create a new **SCC file**. To do so, select the **Menu** button and click **New**. A new untitled SCC file is created with the first step of the procedure displayed on it:

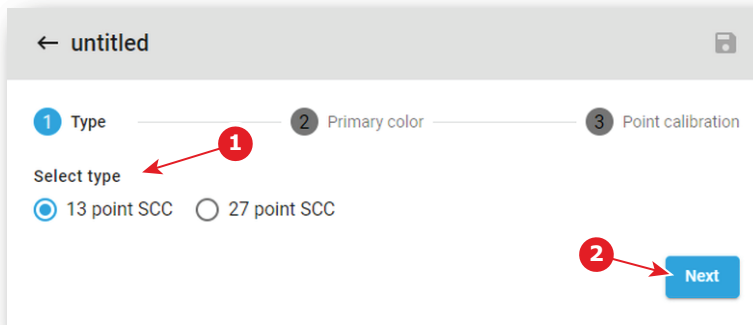

Image 9–25

- Select the SCC file type (reference 1). The number of points will define the number of measures needed in the next steps. The *13 points* SCC files are usually used (default value), but the *27 points* SCC files are sometimes used for post production studios setup (more accurate).
- Click Next (reference 2) to access the step 2.

Page dedicated to the primary color measuring is displayed. This page will be used to specify reference values (x, y coordinates) for each primary color. This will help in the next step to calculate the relative contribution of the primary colors to the color points measured on the different points on the screen.

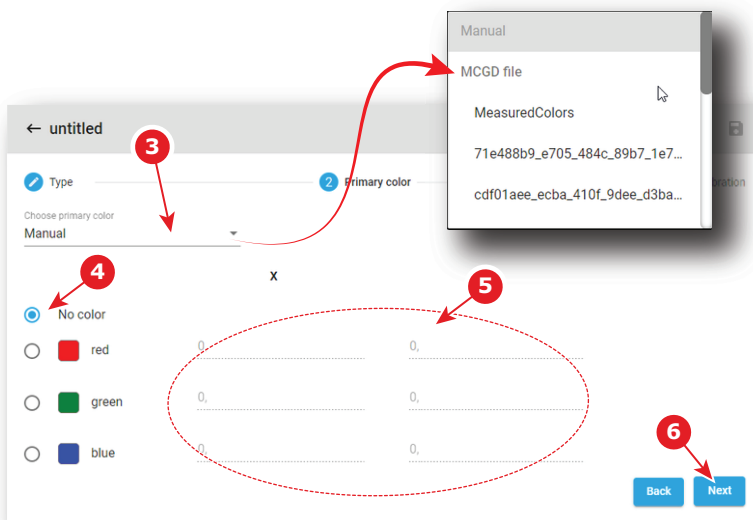



Image 9–26

- In drop down box (reference 3) select a MCGD file already created during projector color calibration in order to reuse color coordinates.

or

use the default value (*Manual*) and introduce manually the color coordinates:

- Select the desired color (e.g. red) by clicking on radio button (reference 4). Test pattern with native color is displayed.
- Measure the color coordinates with the photospectrometer for that specific color and enter the x and y coordinates in the appropriate fields (reference 5).
- Repeat this procedure for all other colors.

 **Tip:** Error messages will be displayed in the bottom of the page if an error is detected (0 value is not authorized, two colors cannot share same coordinates, ...)

- Click Next (reference 6) to access the step 3.

Page dedicated to point calibration measurement is displayed. This page will be used to specify references values (x, y coordinates) for each area. In the upper left corner (reference 7), the active PCF and Screen files are displayed.

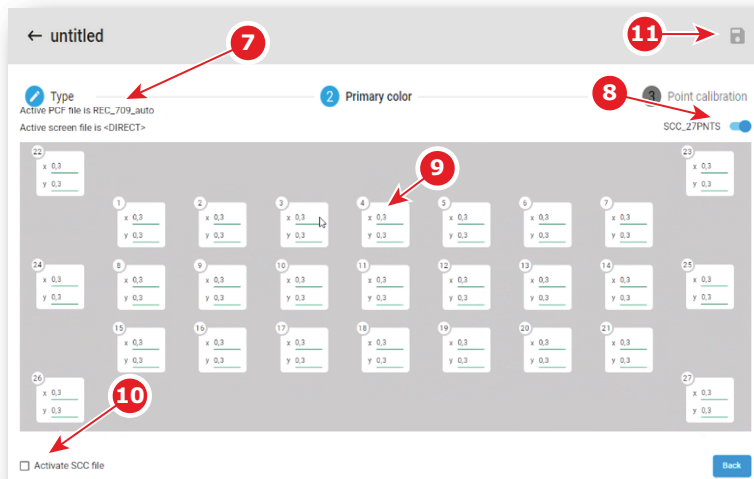

Image 9–27 27 points of calibration

- Click toggle button (reference 8) to activate test pattern. The appropriate SCC test pattern is displayed.
- Measure the x and y coordinates with the photospectrometer for each white square area displayed on screen in order to complete values in all input fields (reference 9).

Limitations and errors:

- 0 value is not authorized. Save button stays grayed until 0 value is detected. This mechanism allows to detect if a field was not filled.
- Values must be specified between 0.2 and 0.4. Values in the range are underlined in green. Values not in this range are underlined in orange.
- The maximum gap between the smallest value and the largest value must be 0.03. If authorized value is exceeded, all concerned values are highlighted in orange.

- Optional: Check the check box *Activate SCC file* (reference 10) to immediately apply created file when you leave the procedure.
- Click on Save icon (reference 11) to save file. This icon is available only if all values was entered and no error was reported.

## 9.5.6 Exporting and importing SCC files

### How to export a single SCC file

1. While in *Configuration > Color Calibration > Spatial color calibration (SCC)*, click on the desired SCC file in the list.

The SCC file is displayed in its expanded form with a menu consisting of several icons.

2. Click the **Export** icon. 

A SCC file (.LUT-SCC) is created and automatically copied in the *Downloads* directory of your computer (e.g. ones2K\_LE.LUT-SCC).

### How to export multiple or all SCC files

1. While in *Configuration > Color Calibration > Spatial color calibration (SCC)*, click the **Select all files** icon in the banner at the top of the SCC files list (reference 1).

All SCC files are selected, and checkboxes will become visible (reference 2).

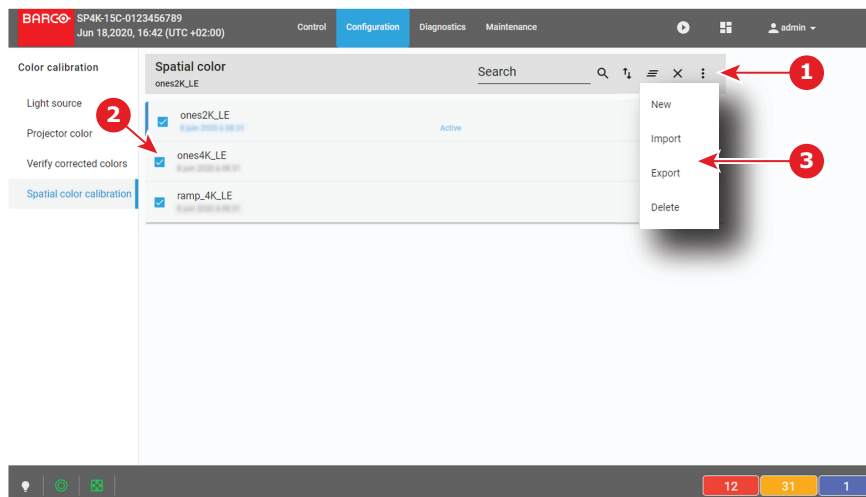

Image 9-28

2. If unwanted SCC files are selected, deselect them by clicking the checkboxes (Reference 2).
3. In the menu located at right of the banner (top of the SCC file list), click **Export**.

All SCC selected are combined in downloadable backup package (.tar), then this package is automatically copied in the *Downloads* directory of your computer.

### Importing SCC files

1. While in *Configuration > Color Calibration > Spatial color calibration (SCC)*, in the menu located at right of the banner (top of the SCC file list), click **Import**.

*Open* window is displayed.

2. Locate and select a SCC file (file with .LUT-SCC extension).

or

Locate and select a backup package (.tar) with several SCC files inside.

3. Click **Open** (reference 4).

If selected files are supported by this projector, they will be included in the SCC files list.



If a file has the same name as a file already present, a confirmation will be required before overwriting.

## 9.5.7 Deleting several SCC files

### How to delete several SCC files

1. While in *Configuration > Color Calibration > Spatial color calibration* (SCC), click the **Select all files** icon in the banner at the top of the SCC files list (reference 1).

All SCC files are selected, and checkboxes will become visible (reference 2).

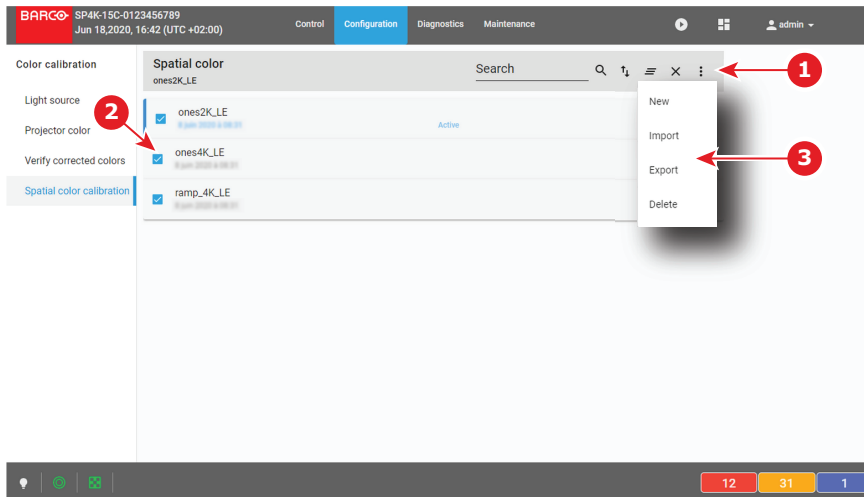

Image 9–29

2. If unwanted SCC files are selected, deselect them by clicking the checkboxes (Reference 2).
3. In the menu located at right of the banner (top of the SCC file list), click **Delete** and confirm with OK. The SCC files selected are definitively removed from the list.

# Configuration - Projector automation

# 10

10.1	Allocating a macro to a general purpose input (GPI) .....	222
10.2	Associating a general purpose output to a system event .....	224
10.3	Changing GPO status manually .....	226

## About this menu

GPIO menu allows you to configure automation system that is present inside the projector.

## 10.1 Allocating a macro to a general purpose input (GPI)

### Location & access

Menu: Configuration > Projector automation > GPI

Level: Administrator, Service technician

### What is rising and falling edge?

The status of a General Purpose Input (GPI) can be either high or low. This means the following:

- **Low:** The voltage between GPI P and GPI N is lower than or equal to 0.5V.
- **High:** The voltage between GPI P and GPI N is higher than or equal to 5.0V.

This translates in the GPI menu into Rising edge and Falling edge. This means the following:

- **Rising edge:** The GPI goes from a low status to a high status (e.g. from 0.5 to 5 V).
- **Falling edge:** The GPI goes from a high status to a low status (e.g. from 5 to 0.5 V).

### What is possible?

The *GPI menu* allows you to allocate a macro file to a rising edge and/or falling edge on one of the general purpose inputs (GPI) of the projector.

There are 8 GPIs available on the projector but only five of these inputs are configurable. The other three are pre-defined and cannot be modified:

- GPI 1 is reserved for 3D L/R input references. This reference indicates which frame is Right and which frame is Left depending and the used polarity. For more info, see 3D settings.
- GPI 2 is reserved for 3D L/R display references. The reference indicated which frame of eye data will be displayed during a specific display frame.
- GPI 3 is reserved for power control.

### Menu overview

Each GPI displayed has a name (reference 1) and a state (reference 2).

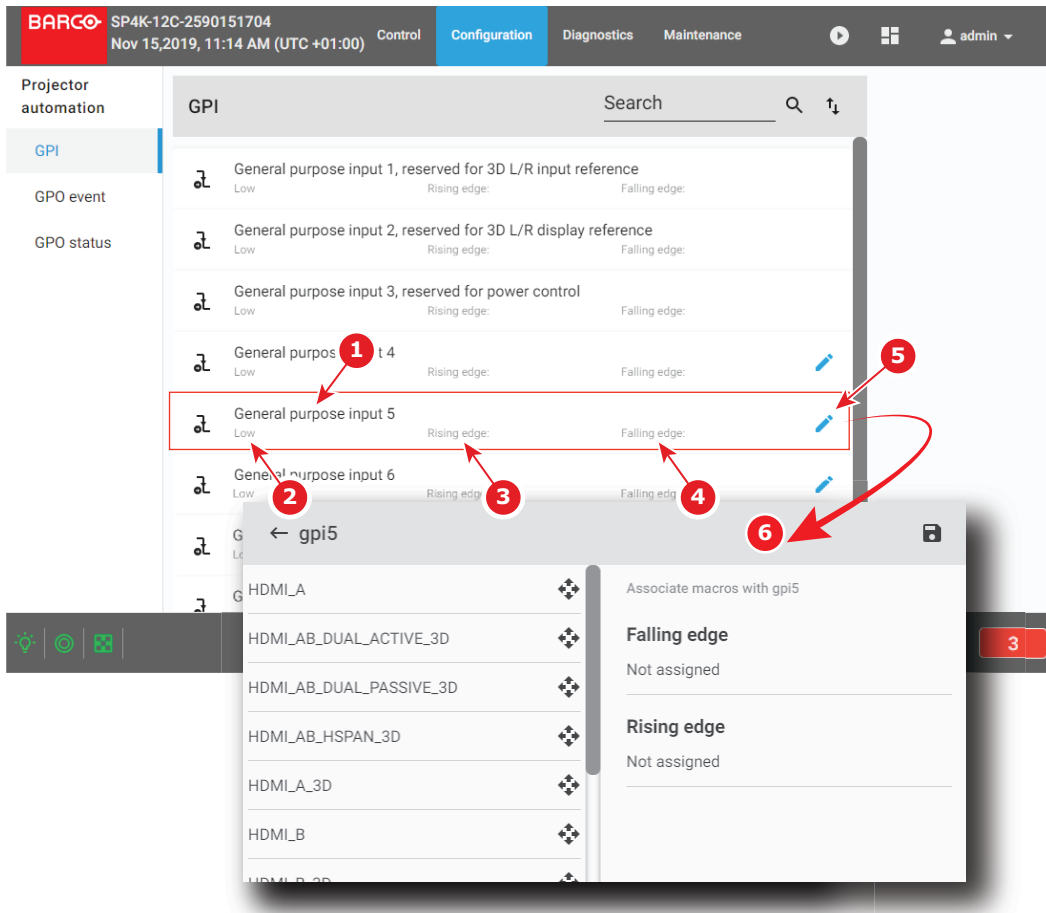



Image 10–1

A macro can be associated to **Rising edge** (reference 3) and/or **Falling edge** (reference 4).

An **Edit** button (reference 5) located to the right of each GPI makes possible to display the GPI in *GPI editor* (reference 6) to modify these associations.

### How to associate a macro

1. In the GPI menu, click on the **Edit** icon.   
The *GPI editor* is displayed.

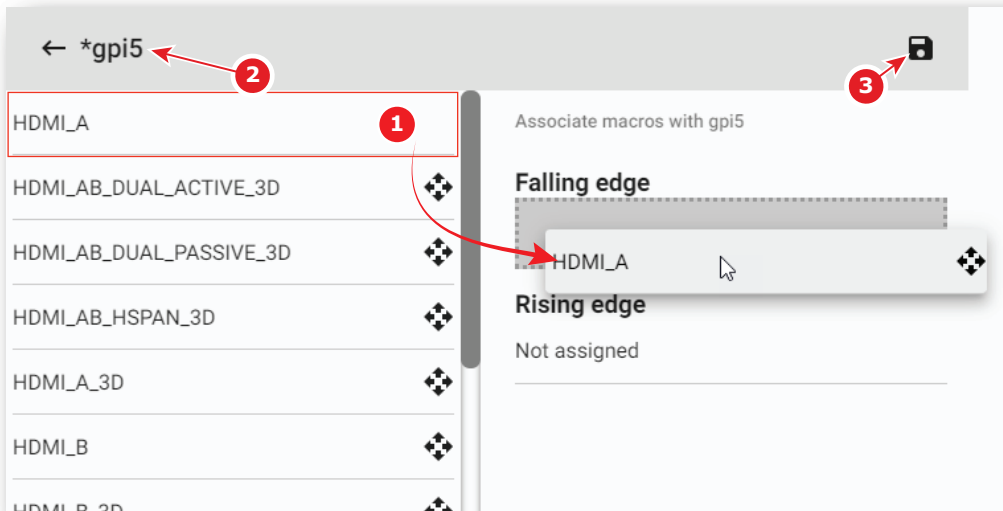

Image 10-2

2. Drag and drop a macro (reference 1) from the list of macros on *Falling edge* or on *Rising edge* to associate this macro to an edge of the GPI.

or

Click the Delete icon to dissociate a macro from the *Falling edge* or from the *Rising edge* of the GPI.

3. Once changed, the GPI name is marked by an asterisk (reference 2) if it has been modified.
4. Click the **Save** icon (reference 3) to save the changes made to the GPI.

## 10.2 Associating a general purpose output to a system event

### Location & access

Menu: Configuration > Projector automation > GPO Event

Level: Administrator, Service technician

### What is possible

The *GPO Event editor* allows you to allocate a system event to a GPO. Also, you can choose the type of action the GPO will take when the associated event triggers.

For example, you can link the projector events **Light On** and **Light Off** to a High and Low action of a GPO. This so that this GPO can trigger the theater curtains to open/close and the theater lights to dim / brighten depending on the status of the Projector Light source.

You can allocate events to five GPO's (GPO 4 to GPO 8). GPO's 1-3 are reserved by the system.

### Menu overview

This menu allows to allocate system events to GPOs (general purpose outputs) available in the Cinema Controller. You can set the GPO in a certain state depending the event to trigger processes in the theatre or control room.

Each event displayed here has a name (reference 1), the name of its allocated GPO + the type of action (reference 2) the GPO will take when the associated event triggers. If no GPO is associated with the event, *Not configured* is displayed instead.



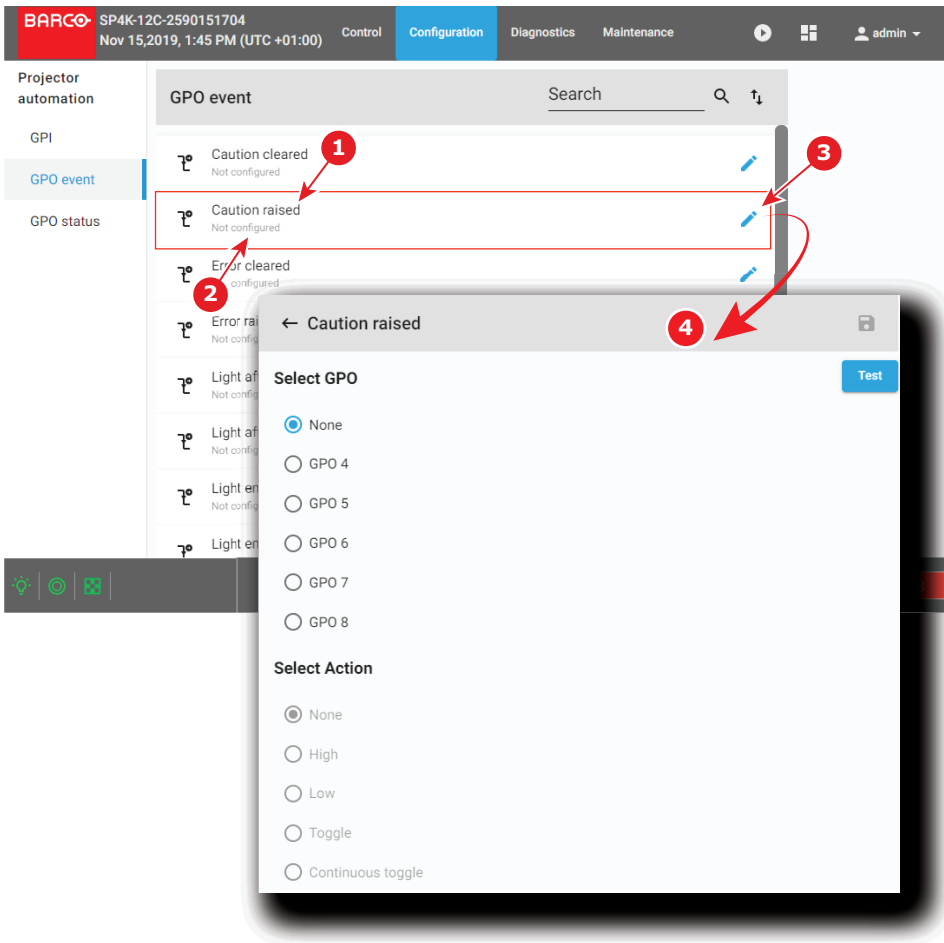

Image 10–3 GPO action menu overview

An **Edit** icon (reference 3) is located on the right-hand side of each event. This allows you to access the *GPO Event editor* (reference 4) in order to allocate said event to a GPO.

### How to allocate a GPO to a system event.

1. While in the *GPO Event* menu, click on the **Edit** icon (reference 3, [Image 10–3](#)).  
The *GPO Event editor* is displayed for the selected event.

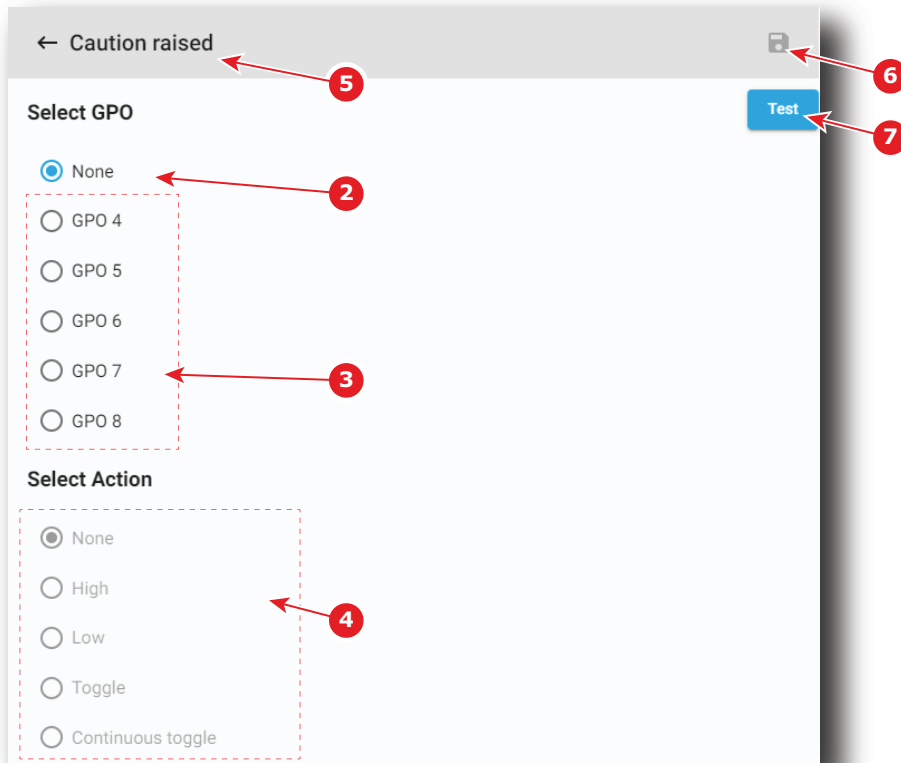

Image 10-4 Example of the GPO Event editor for the event "Caution raised"

2. Select *the desired GPO* to allocate this event.:  
or  
Click **None** (reference 2, [Image 10-4](#)) if you do not want to allocate this event to any GPO.  
GPO actions (reference 4) are disabled until a GPO is selected.
3. Select the desired GPO action you want to trigger on the GPO.  
Click the radio button (reference 4) corresponding to action that you want to trigger on the GPO.
4. If the event was modified during the previous steps, an asterisk is displayed before the event name (reference 5) and **Save** is now available (reference 6).
5. Click **Save** (reference 6) to save the changes made to the event.
6. Click **Test** (reference 7) allows testing the GPO like if the event was raised.

## 10.3 Changing GPO status manually

### Location & access

Menu: Configuration > Projector automation> GPO Status

Level: Administrator, Service technician

### Menu overview

This menu allows you to manage status of the GPOs (general purpose outputs) present inside the projector. This can be done to test associated automation systems (e.g. curtains, theater lights, etc).

The first three (GPO1, GPO2 and GPO3) are reserved by the system. You cannot manually modify their status.

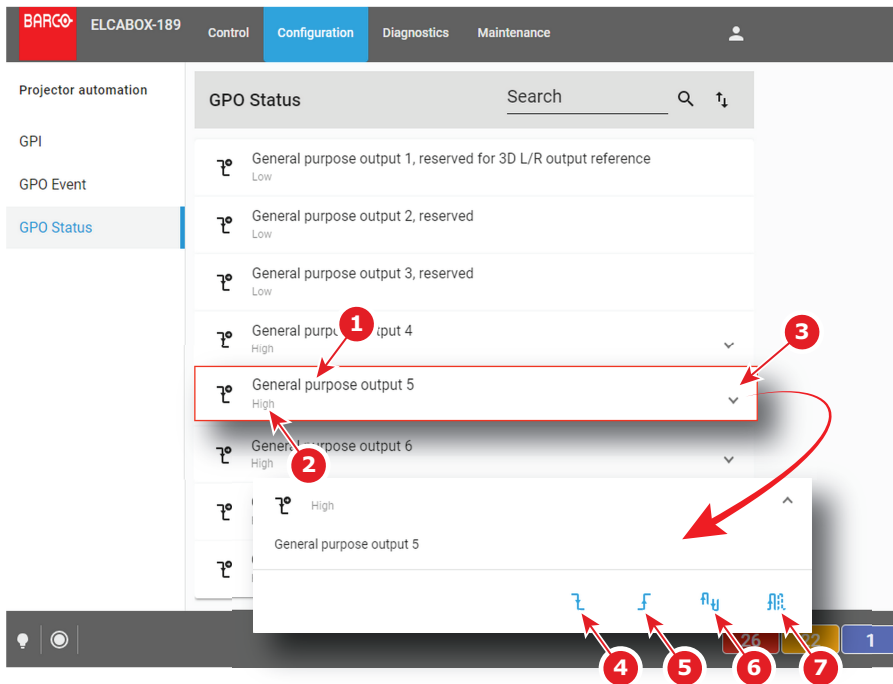

Image 10–5

Each GPO displayed here has a name (reference 1) and a state (reference 2).

An **expand** button (reference 3) is located to the right of each GPO. This button allows to show the GPO in its expanded form and displays a contextual menu.

Following actions are available in this menu:

- **Low** button (reference 4) forces the GPO to low state.
- **High** button (reference 5) forces the GPO to high state.
- **Toggle** button (reference 6) switches the GPO to the opposite state then returns to previous state (a single pulse).
- **Continuous toggle** button (reference 7) forces the GPO to send continuous pulses.

## How to change the status

1. Click on the **Expand** button (reference 3) located at the right of the GPO.

The GPO is displayed in its expanded form with menu.

2. Click on one of the menu buttons to change the status of the GPO (references 4-7).

The Status of the GPO is changed and its new state is displayed next to the GPO in the list (reference 2).



# Configuration - Media server automation

# 11

11.1	Devices .....	230
11.2	Groups .....	233
11.3	User cues .....	237

## About this chapter

The media server automation server chapter allows to setup automation devices and cues to automate processes during a show.

## 11.1 Devices

### 11.1.1 About devices

#### Location & access

Menu: Configuration > Media server automation > Devices

Level: Administrator, Service technician

#### Overview

Devices that could be used for automatic actions can be configured during adding a device. Multiple devices of the same type can be added to the ICMP-X by using a different device name. This device name will be used to identify the port.

The following devices are available:

- **JNIOR** : Ethernet I/O controller Device. This device provides a full suit of solutions (additional GPIO) to make digital cinema automation easier. It makes it possible to control e.g. the theater infrastructure such as lights, sound, etc. .
- **TCP** : all devices that use the TCP protocol. Transmission Control Protocol is an Ethernet connection to send simple user messages.
- **UDP** : all devices that use the UDP protocol. User Datagram Protocol is an Ethernet connection to send user messages in quick way but without guaranty that the message is received.

When adding a device, the following must be configured before the device can be used:

- **Device name**: a unique readable name of the device.
- **Hostname/IP**: IP address of the device in the theater network.
- **Port**: IP port number associated with the device.
- **Login**: used by the ICMP-X, in combination with the password, to establish communication with the remote device.
- **Password**: used by the ICMP-X, in combination with the login, to establish communication with the remote device.



Ports, logins and passwords must be retrieved from the unit manufacturer and are not provided by Barco.

### 11.1.2 Add a new device

#### Location & access

Menu: Media server automation > Devices

Level : Administrator, Service technician

#### How to add

1. While in *Configuration > Media sever automation > Device*, click on the Device menu (reference 1) located on the top right of the list and select **New** (reference 2)

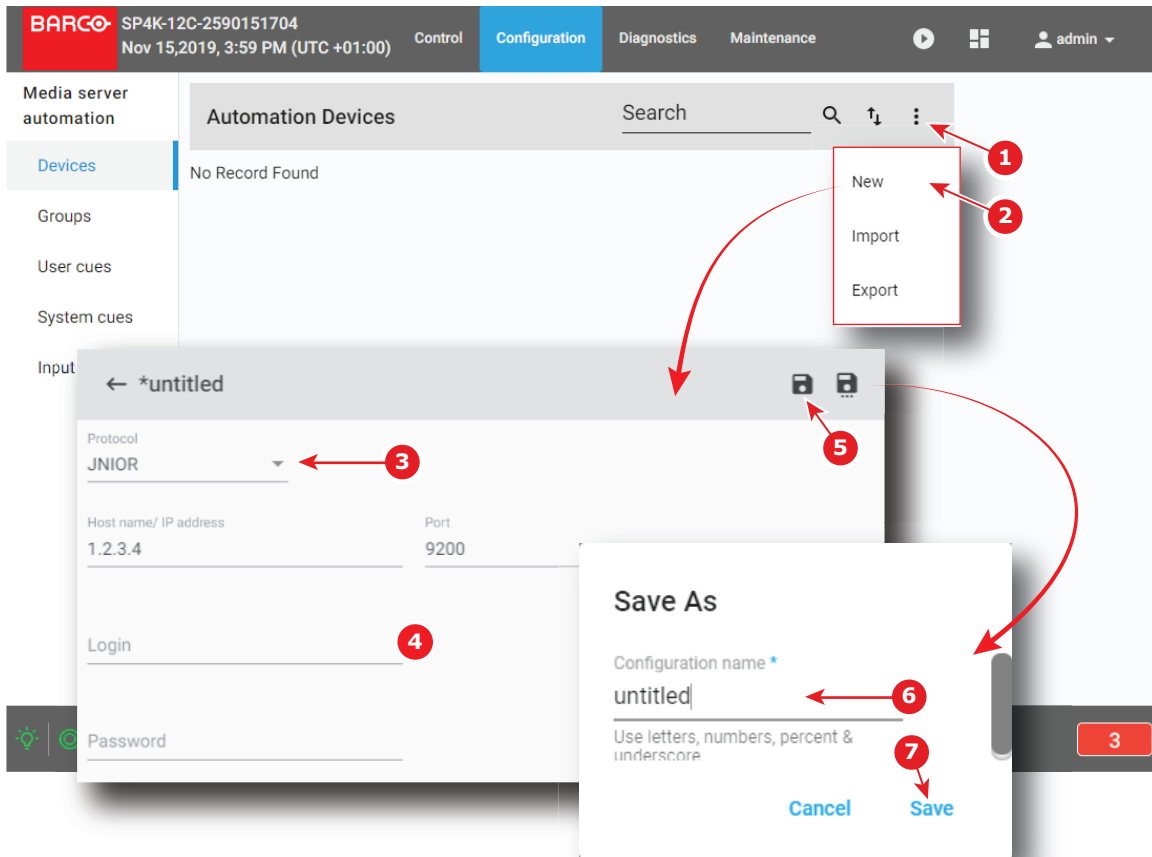

Image 11-1 Example of adding a new device

The New device window is displayed.

2. Select the desired device protocol by clicking on the *Protocol* drop down list (reference 3). The rest of the form will change depending your selection.
3. Fill out the form, depending on the chosen protocol (reference 4).

JNIOR	TCP	UDP
Host name / IP address + Port number	Host name / IP address + Port number	Host name / IP address + Port number
Login	Login text	
Password	Maintain connection	

4. Click the **Save** icon to save the new device configuration (reference 5). The Save As dialog prompts.
5. Enter a configuration name (reference 6) and confirm with **Save** (reference 7). The new device is added to the list of devices.

### 11.1.3 Update an existing device

#### Location & access

Menu: Media server automation > Devices

Level : Administrator, Service technician

## How to update

1. While in *Configuration > Media sever automation > Device*, click on a device in the list that you need to update.

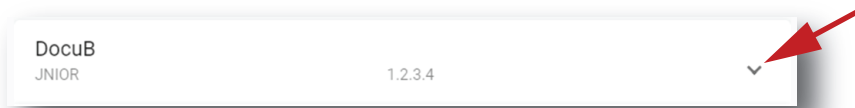

Image 11-2

The device is displayed in its expanded form with a menu.

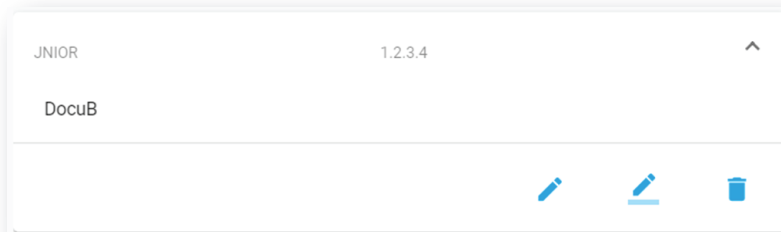

Image 11-3

2. To rename the device, click on the **Rename** icon to open the Rename window.  The rename dialog is prompted.

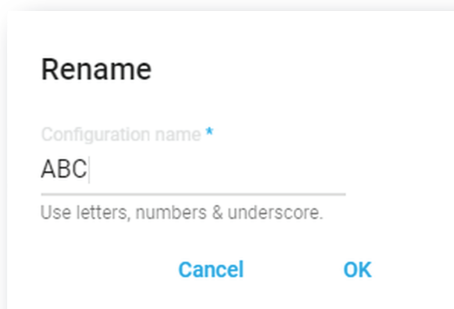



Image 11-4

3. Enter a new name and confirm with **OK**.
4. To edit other settings, click on the edit icon to open the settings window. 
5. Change the necessary settings and click **Save** icon to save the changes. Or click **Save as** to save the updated settings on another name.

### 11.1.4 Delete an existing device

#### Location & access

Menu: Media server automation > Devices

Level : Administrator, Service technician



## How to delete

1. While in *Configuration > Media sever automation > Device*, click on a device in the list that you need to delete.

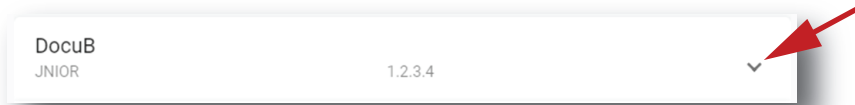

Image 11–5

The device is displayed in its expanded form with a menu.

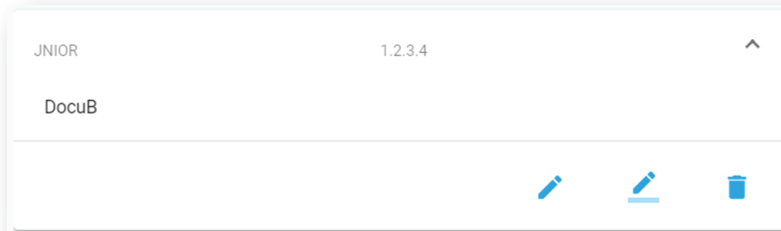

Image 11–6

2. Click on the trash bin icon to delete.  
The selected device is removed from the list.

### 11.1.5 Import and export devices

#### Location & access

Menu: Media server automation > Devices

Level : Administrator, Service technician

#### How to import or export

Mechanisms to import or export devices are similar to the mechanisms used for automation cues. Please refer to sections dedicated to import or export automation setting in [“User cues”, page 237](#).

## 11.2 Groups

### 11.2.1 Creating a new automation group



#### Location & access

Menu: Media server automation > Groups

Level : Administrator, Service technician

#### How to create a new automation group

1. While in *Configuration > Media sever automation > Groups*, click on the menu icon (reference 1) located on the top right of the menu and select **New** (reference 2).

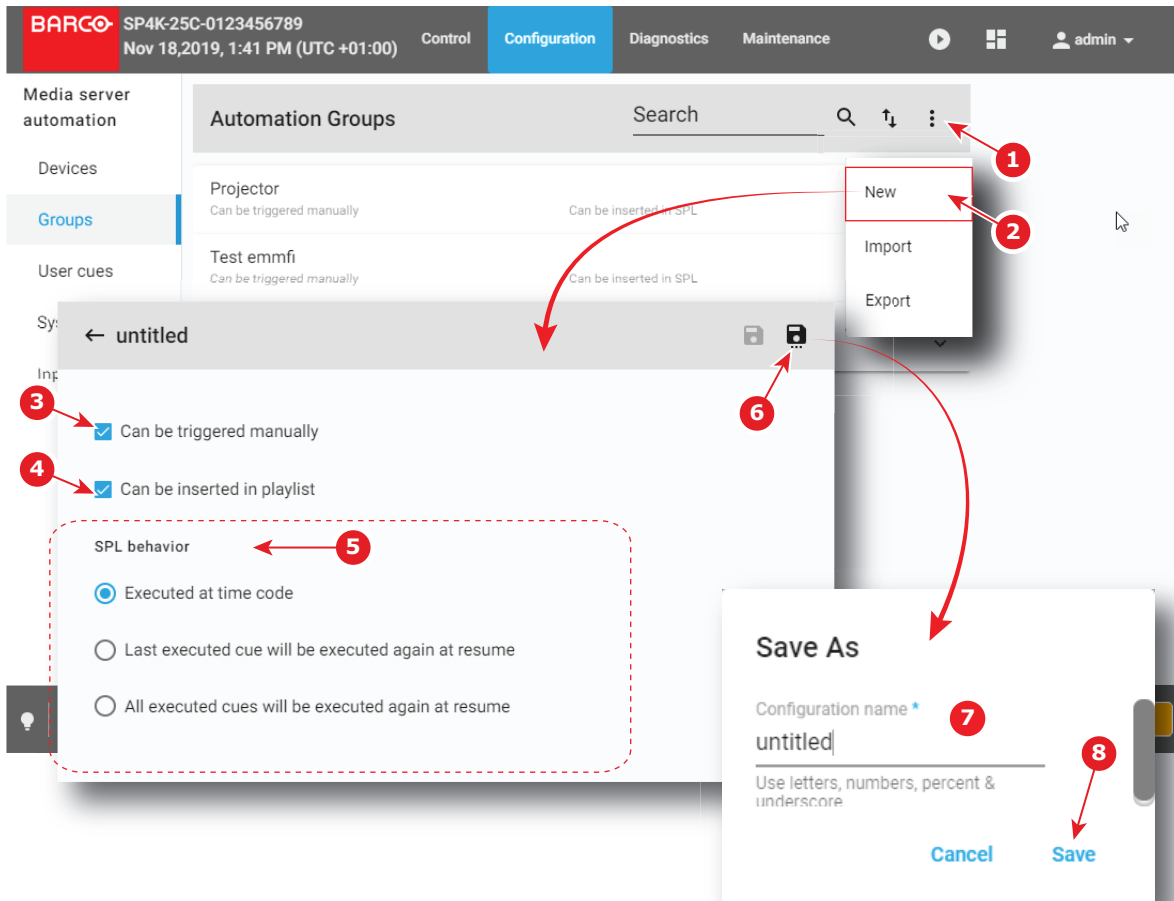

Image 11-7

A new untitled Automation Group window is displayed.

2. To allow manual triggering of the cues in this group, select the checkbox *Can be triggered manually* (reference 3).
3. To allow inserting user cues of this group in SPL, select the checkbox *Can be inserted in SPL* (reference 4).
4. Select the desired SPL behavior (reference 5).

This option affects the behavior of Cues during positioning in a show:

- *Execute at time code*: When starting from any position in the SPL, from all cues previous to that position, only the last one of the group is executed. This would commonly be used to restart with the expected state at the position in the playlist.
- *Last executed cue will be executed again at resume*: When starting from any position, any cue previous to that position is ignored. This can be used to trigger some notifications for instance or for pause and Intermission Cues.
- *All executed cues will be executed again at resume*: When starting from any position, any cue previous to that position is executed. This can be used when using some pulse based external automation device that counts the number of pulses since the beginning of the show. A reset action should be foreseen.

5. Click **Save as** button (reference 6).  
The *Save as* dialog is prompted.
6. Enter a new group name (reference 7) and confirm with **Save** (reference 8).

## 11.2.2 Edit an existing group

### Location & access

Menu: Media server automation > Groups

Level : Administrator, Service technician

### How to edit a group

1. While in *Configuration > Media sever automation > Groups*, click the expand button of the group that you need to edit.

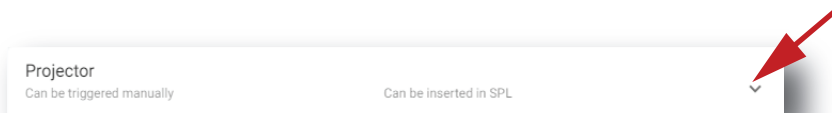



Image 11-8

The group is displayed in its expanded form with a menu at the bottom.

2. Click on the **Edit** button to open the current settings. 

Change the setting as described in [“Creating a new automation group”, page 233](#)

## 11.2.3 Rename a group

### Location & access

Menu: Media server automation > Groups

Level : Administrator, Service technician

### How to rename

1. While in *Configuration > Media sever automation > Groups*, click on the expand button of the group that you want to rename.

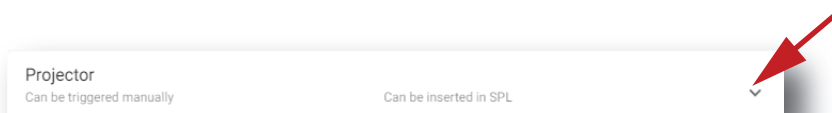



Image 11-9

The group is displayed in its expanded form with a menu at the bottom.

2. Click on the **Rename** button to open the current settings. 

A *Rename* window opens.

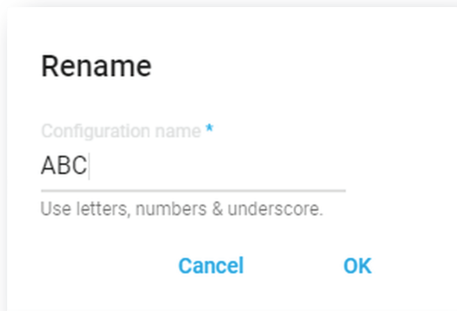

Image 11–10

3. Enter a new name and confirm with **OK**.

## 11.2.4 Delete a group

### Location & access

Menu: Media server automation > Groups

Level : Administrator, Service technician

### How to delete

1. While in *Configuration > Media sever automation > Groups*, click on the expand button of the group that you want to delete.

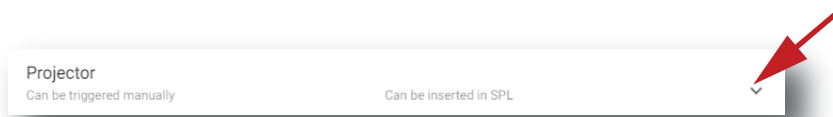

Image 11–11

The group is displayed in its expanded form with a menu at the bottom.

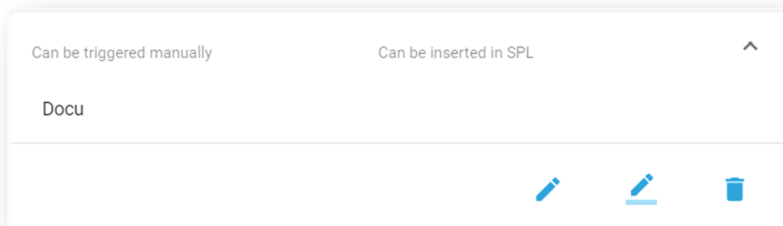



Image 11–12

2. Click on the trash bin icon to delete.  The selected group is removed from the list.

## 11.2.5 Import and export groups

### Location & access

Menu: Media server automation > Groups

Level : Administrator, Service technician

## How to import or export

Mechanisms to import or export groups are similar to the mechanisms used for automation cues. Please refer to sections dedicated to import or export automation setting in “User cues”, page 237.

# 11.3 User cues

## 11.3.1 About automation cues

### Location & access

Menu: Configuration > Media server automation > User cues

Level: Administrator, Service technician

### Overview

**Automation Cues** are automatic events that are triggered from different sources. Activation of a cue can trigger actions (commands) that will be executed by the automation engine.

There are 3 automation cues types available:

- **User Cues** (output cues): cues that are configured on the ICMP-X and can be executed by the end user manually or can be executed by the Player during the projection of a show playlist (cues inserted inside the SPL).
- **Input Cues**: predefined cues that are triggered on the detection of an input by modules (e.g. GPIO events).
- **System Cues**: predefined cues that are triggered by software modules when detecting a new condition (e.g. Player events).

Command: when an event cue is triggered, the ICMP-X automation engine will execute all actions (commands) that are configured for the event cue. The Commands must have a target device (module that will implement the action), a Command Name to identify the command and some Parameters and an optional delay.

### User Cues

A user cue type must be defined in a group of cues (e.g. Light, Projection lamp, etc.) in order to present the cues to end users with additional settings.

Group Name	Name of the group in the Web Commander application
Can be triggered manually	<p>“Checked” means the end user can trigger the cue manually.</p> <p>“Unchecked” means that the cue only can be triggered via a SPL.</p>
Can be inserted in SPL	<p>“Checked” means the end user can use (insert) the cues of this group in a Show play list via Web Commander.</p> <p>“Unchecked” means the end user cannot use the cues of this group in a Show play list via Web Commander.</p>

### Input Cues

Input Cues are predefined cues that are triggered on the detection of an input by modules. Events list already available:

Device type	Events List
GPIO (General Purpose Input/ Output)	<p>Events that will be sent from the ICMP-X General Purpose Input:</p> <ul style="list-style-type: none"> <li>• On Input 1 Up. The Cue will be activated when changing the status of input channel from 0 to 1.</li> <li>• ../..</li> </ul>

## System Cues

System Cues are predefined cues that are triggered by software modules when detecting a new condition. Events list already available:

Software Device type	Events List
PLAYER	<p>Events that will be sent from the ICMP-X Player:</p> <ul style="list-style-type: none"> <li>• On Dark Screen Detected</li> <li>• On Play Action</li> <li>• On Stop Action</li> <li>• On Pause Action</li> <li>• On Resume Action</li> <li>• On Player Playing</li> <li>• On Player Paused</li> <li>• On Player Error</li> <li>• On Show Start</li> <li>• On Show End</li> <li>• On Feature Start</li> <li>• On Emergency Stop</li> <li>• On Play stopped on error</li> </ul>

## Predefined automation devices and actions

A list of devices and actions are predefined by the first use.

Device name	Description	Actions	Explanation
GPIO	GPIO commands	Set Outputs	
		Pulse Up	
		Pulse Down	
		Set Up	
		Set Down	
PLAYER	Player commands	Play	Play a clip
		Stop	Stop playing
		Pause	Set playing on pause
		Pause (seconds)	Set playing on pause for x seconds
		Resume	Continue playing
		Enable Schedule	Schedule enabled
		Disable Schedule	Schedule disabled
		Emergency Stop	Immediately stop
		Rewind (seconds)	Go back for x seconds
		Play Scheduled Show	Play a scheduled show
		Insert Show	
		Next	switch player position to the next clip
		Previous	switch player position to the previous clip
		Jump To Clip End	set player position to the end of current clip
		Recover	to recover player position when unexpectedly stopped
Recover And Play	to recover player position when unexpectedly stopped and restart playback		

Device name	Description	Actions	Explanation
		Ignore Recovery	player ignores to recover the playback position
		Clear	clear the CPL or SPL in the player
		Enable Repeat	enable the loop mode in the player
		Disable Repeat	disable the loop mode in the player
		Set Marker	set position marker where player can jump to
		Jump To Marker	change player position to marker position
PROJECTOR	Projector commands	Close Dowser	Dowser will close
		Open Dowser	Dowser will open
		Turn Lamp On	Lamp will turn on
		Turn Lamp Off	Lamp will turn off
		Execute Macro	Macro will be executed
		Execute Macro & check	Macro will be executed and checked if correctly executed
TCP or UDP (device)	TCP or UDP commands	Send Text	to send a text command to the device <sup>3</sup>
		Send Hex	to send a hex value to the device
		Send Binary	to send a binary value to the device

## 11.3.2 Create a new User Cue

### Location & access

Menu: Media server automation > User cues

Level : Administrator, Service technician

### How to create

1. While in *Configuration > Media sever automation > User cues*, click on the Cue menu (reference 1) located on the top right of the list and select **Add** (reference 2)

3. Special characters or delimiters have to be replaced by the “\” character followed by the corresponding hexadecimal value on two digits. For instance, the command can send the text “mute=0\0D\0A”, where “\0D” replaces the carriage return (“\r”) and “\0A” replaces the new line (“\n”).

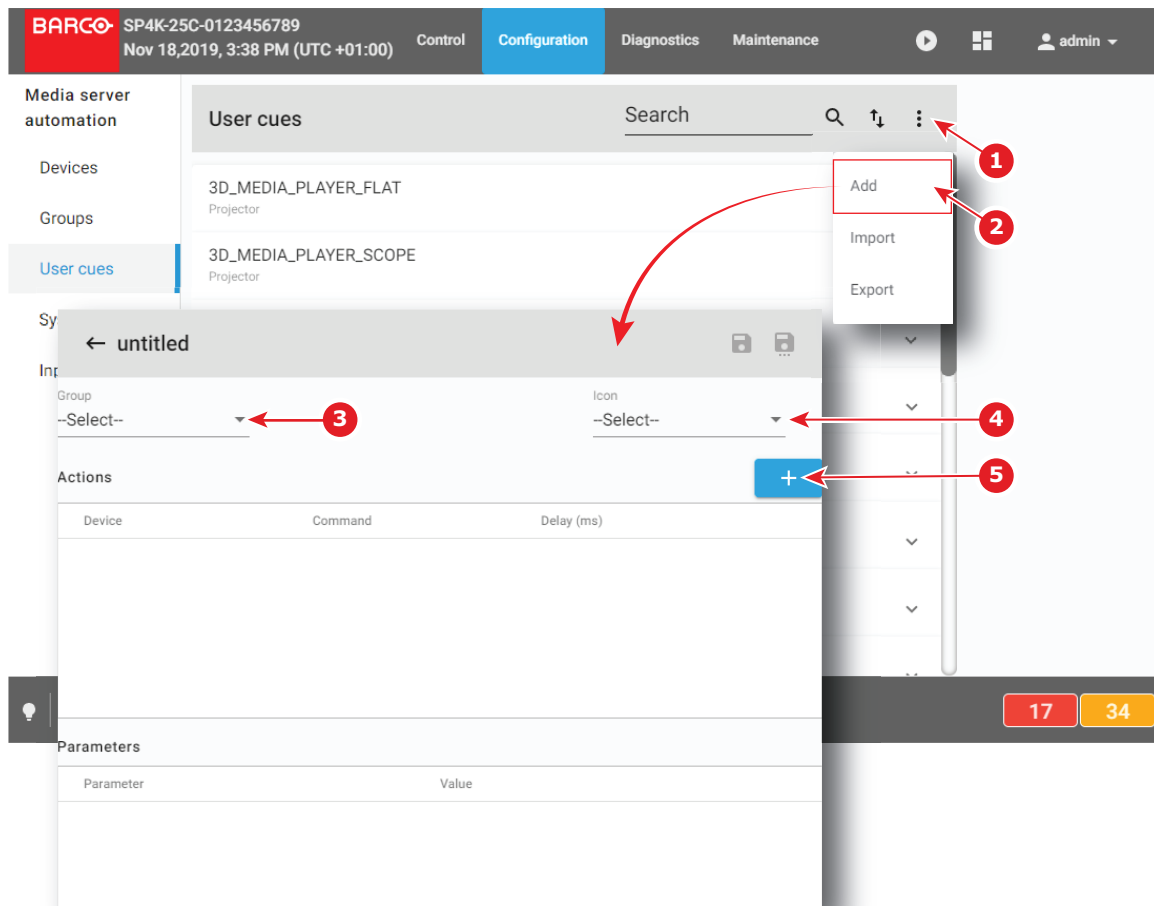

Image 11-13

A new untitled user cue is displayed.

2. A user cue is created within a group. Click on the drop down box and select the desired group (reference 3).
3. A cue can be indicated by an icon. Click on the drop down box in the icon field and select the desired icon (reference 4).
4. Add a first action to your new cue. Click on the + button to open the cue editor pane (reference 5).
5. Click on the drop down box below Device and select an existing device that will execute the action (reference 6).



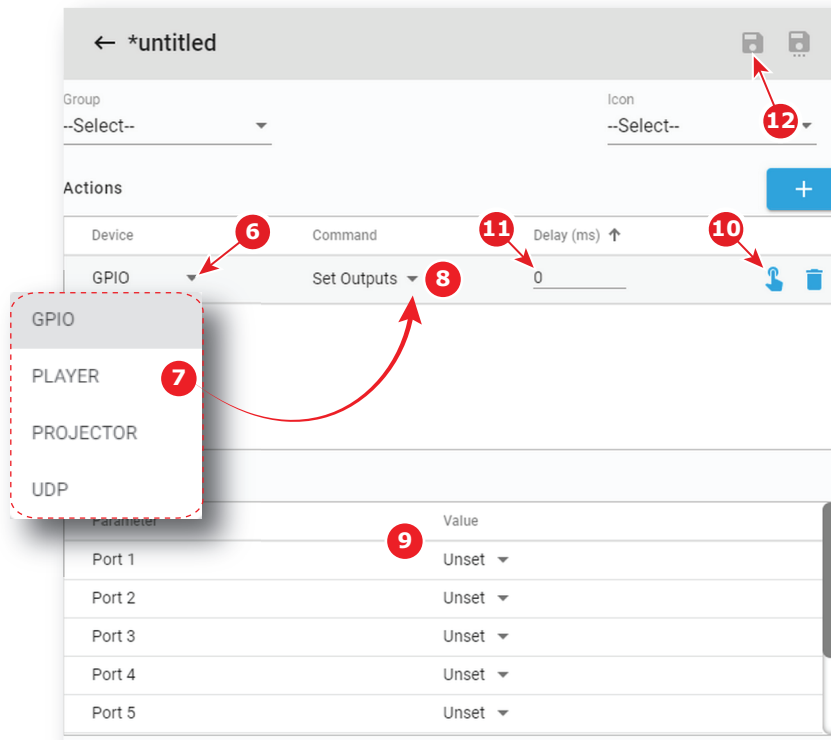

Image 11–14

By default there are four types of devices able to execute an action:

- **GPIO** (General Purpose Input/Output) : this device allows to interact with the 8 GPO outputs of the ICMP.
- **PLAYER**: Allows to access a set of commands that will be sent to the ICMP Player.
- **PROJECTOR**: Allows to access the available projector macros.
- **UDP**: Allows to send text commands to devices.

Other devices could be added via the devices configuration page.

6. Click on the command drop down and select the command out of the available commands (reference 7). The command list changes depending on the selected device.

Click on the drop down list and select a *Command* (reference 8).

For the complete list of devices and commands, see “[Devices and commands](#)”, page 242.

Some commands require additional parameters such as channel number or pulse duration for GPIO, the name of the macro to be executed by the projector. In all these cases, extra fields are displayed in the parameter pane (reference 9).

7. Optional test: click **Execute** (reference 10) to directly test action.

Result of the test is displayed and corrective actions could be immediately done.

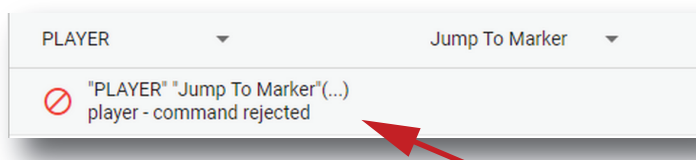

Image 11–15

8. Enter a delay before a command is executed (reference 11).
9. Click the **Save** icon (reference 12).

A *Save as* dialog is prompted.

**10.** Enter a name for the cue and confirm with **Save**.

Click **Save**.

### 11.3.3 Devices and commands

#### Overview

Device type	Commands List
GPIO	<ul style="list-style-type: none"> <li>Set output: to set one or more outputs to the desired value (0 or 1).</li> <li>Pulse up: to realize a rapid change of amplitude of the output (0 to 1).</li> <li>Pulse Down: to realize a rapid change of amplitude of the output (1 to 0).</li> <li>Set Up: to set output to 1.</li> <li>Set Down: to set output to 0.</li> </ul>
PLAYER	<ul style="list-style-type: none"> <li>Play: to start or resume the playback</li> <li>Stop: to stop the playback</li> <li>Pause: to pause the playback. The last played image remains on the screen. If the 'Duration in minutes' parameter is different than 0, the playback will automatically resume after the given amount of time.</li> <li>Pause (seconds): pause is defined in seconds</li> <li>Resume: to resume a paused playback.</li> <li>Enable Schedule: to enable the scheduled mode.</li> <li>Disable Schedule: to disable the scheduled mode.</li> <li>Emergency Stop: to disable the scheduled mode, stop the playback and trigger the "On Emergency Stop" event.</li> <li>Insert Show: to dynamically insert a show inside another main show in which the cue was inserted. The insertion is done at selection time. Note that other actions in the cue will be ignored.</li> <li>Rewind (seconds): to rewind the defined time.</li> <li>Play Scheduled Show: to start the playback of a scheduled show between scheduled time and maximum delay.</li> </ul>
Projector	<ul style="list-style-type: none"> <li>Close Dowser: to close the dowser of the projector.</li> <li>Open Dowser: to open the dowser of the projector.</li> <li>Turn Lamp On: to turn the projector lamp on.</li> <li>Turn Lamp Off: to turn the projector lamp off.</li> <li>Execute Macro: to request macro execution by the projector. Macro selection from macro list is necessary.</li> </ul>
TCP/UDP (device)	<ul style="list-style-type: none"> <li>Send Text: to send a text command to the device. Special characters or delimiters have to be replaced by the "\" character followed by the corresponding hexadecimal value on two digits. For instance, the command can send the text "mute=0\0D\0A", where "\0D" replaces the carriage return ("\r") and "\0A" replaces the new line ("\n").</li> <li>Send Hex: to send a hex value to the device.</li> <li>Send Binary: to send a binary value to the device.</li> </ul>
JNIOR	<ul style="list-style-type: none"> <li>Set outputs: to set one or more outputs to the desired value (0 or 1).</li> <li>Pulse up: to realize a rapid change of amplitude of the output (0 to 1).</li> <li>Pulse Down: to realize a rapid change of amplitude of the output (1 to 0).</li> <li>Set Up: to set output to 1.</li> <li>Set Down: to set output to 0.</li> <li>Clear input counters: to clear counters for the given JNIOR input.</li> <li>Clear input usage meter: to clear the usage meter for the given JNIOR input.</li> <li>Clear output usage meter: to clear the usage meter for the given JNIOR output.</li> <li>Reset input latch: to reset the given JNIOR input latch.</li> <li>Execute Macro: to request a macro execution by the JNIOR. The macro name should match the name of an existing macro on the JNIOR.</li> </ul>

### 11.3.4 Edit a user cue

#### Location & access

Menu: Media server automation > User cues

Level : Administrator, Service technician

#### How to edit

1. While in *Configuration > Media sever automation > User cues*, click on the expand button of the cue to edit.

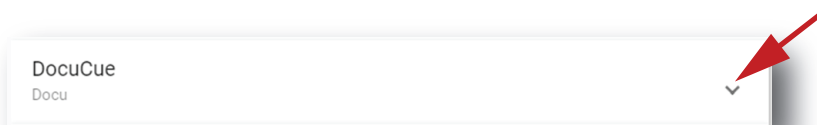

Image 11–16

The user cue is displayed in its expanded form with a menu.

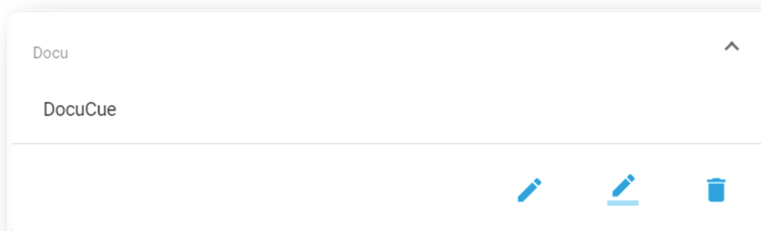



Image 11–17

2. Click on the **Edit** icon to open the current settings. 

Change the setting as described in “[Create a new User Cue](#)”, page 239.

### 11.3.5 Rename a user cue

#### Location & access

Menu: Media server automation > User cues

Level : Administrator, Service technician

#### How to rename

1. While in *Configuration > Media sever automation > User cues*, click on the expand button of the cue to edit.



Image 11–18

The user cue is displayed in its expanded form with a menu.

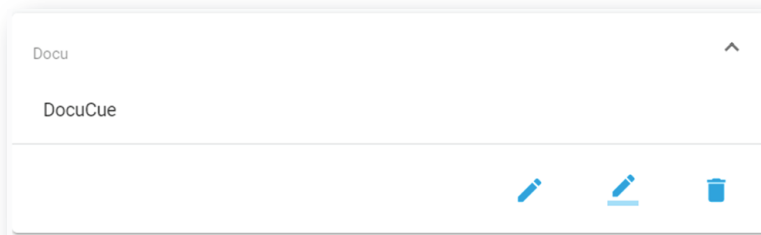

Image 11-19

2. Click on the **Rename** button to open the rename window.



The Rename dialog is prompted.

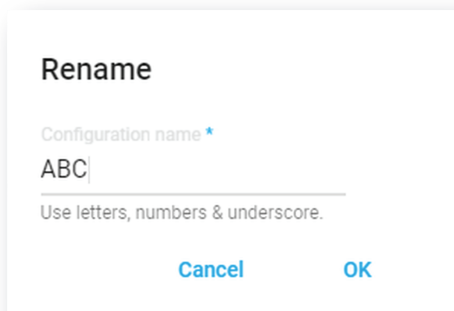

Image 11-20

3. Enter a name  
Click **OK**.

### 11.3.6 Delete a user cue

#### Location & access

Menu: Media server automation > User cues

Level : Administrator, Service technician

#### How to delete

1. While in *Configuration > Media sever automation > User cues*, click on the expand button of the cue to edit.

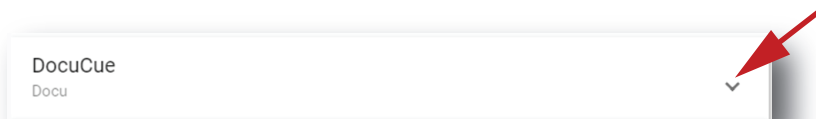

Image 11-21

The user cue is displayed in its expanded form with a menu.

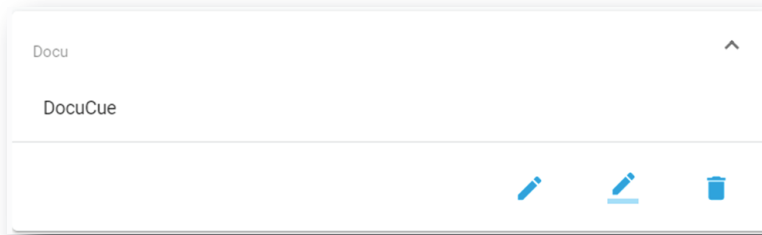



Image 11-22

2. Click on the trash bin icon to delete. 

The selected user cue is removed from the list.

### 11.3.7 Editing a System Cue

#### Location & access

Menu: Media server automation > System cues

Level : Administrator, Service technician

#### How to add an action?

1. While in *Configuration > Media sever automation > System cues*, click on the **Edit** icon of the desired system cue (reference 1).

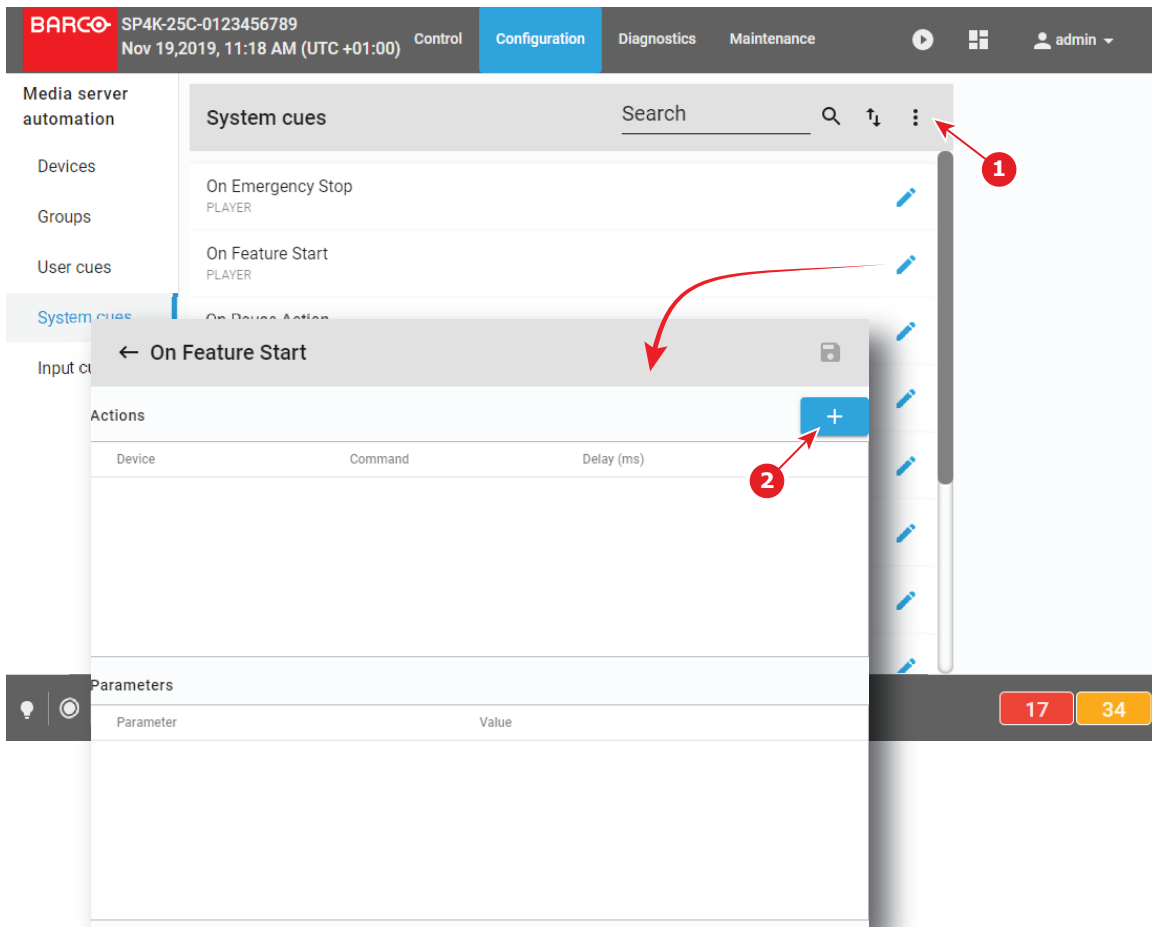

Image 11-23

The current action list opens.

2. Click on the + button (reference 2) to add a new action.
3. Click on the drop down box below *Device* (reference 3) and select an existing device that will execute the action (reference 4).

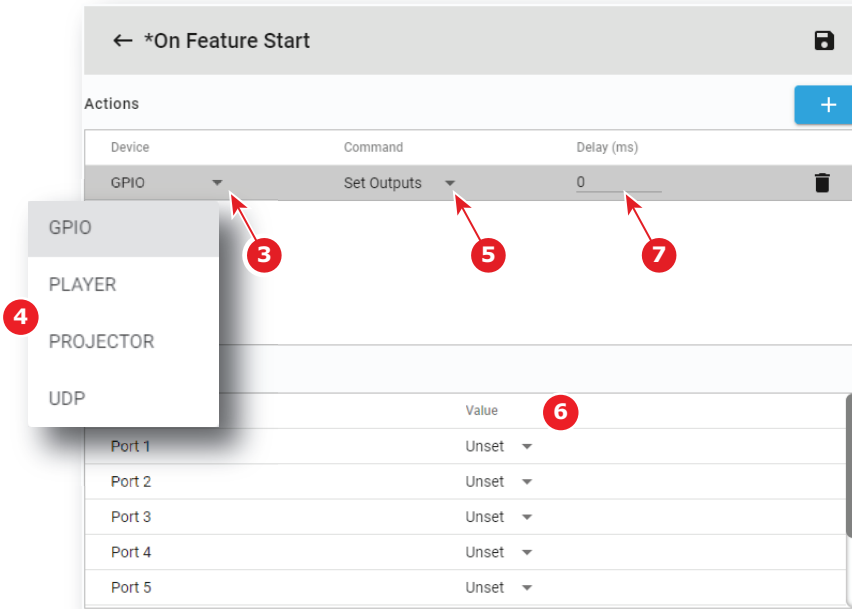

Image 11–24

By default there are four types of devices able to execute an action:

- **GPIO** (General Purpose Input/Output) : this device allows to interact with the 8 GPO outputs of the ICMP.
- **PLAYER**: Allows to access a set of commands tat will be sent to the ICMP Player.
- **PROJECTOR**: Allows to access the available projector macros.
- **UDP**: Allows to send text commands to devices.

Other devices can be added via the devices configuration page. For the complete list of devices and correlated commands, see “[Devices and commands](#)”, [page 242](#).

4. Click on the command drop down and select the desired command (reference 5). The command list changes depending on the selected device.

Some commands require additional parameters such as channel number or pulse duration for GPIO, the name of the macro to be executed by the projector. In all these cases, extra fields are displayed in the parameter pane (reference 6).

5. Enter a delay before a command is executed (reference 7).
6. Click the **Save** icon.

### How to remove an action?

1. While editing a System queue, click on the trash bin icon of the undesired action (reference 8).

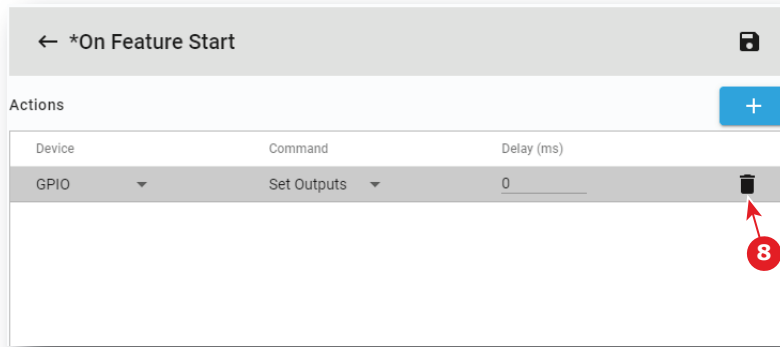

Image 11-25

## 11.3.8 Adding an Input Cue to an event

### Location & access

Menu: Media server automation > Input cues

Level : Administrator, Service technician

### How to create

1. While in *Configuration > Media sever automation > Input cues*, click on the Cue menu (reference 1) located on the top right of the list and select **Add** (reference 2).

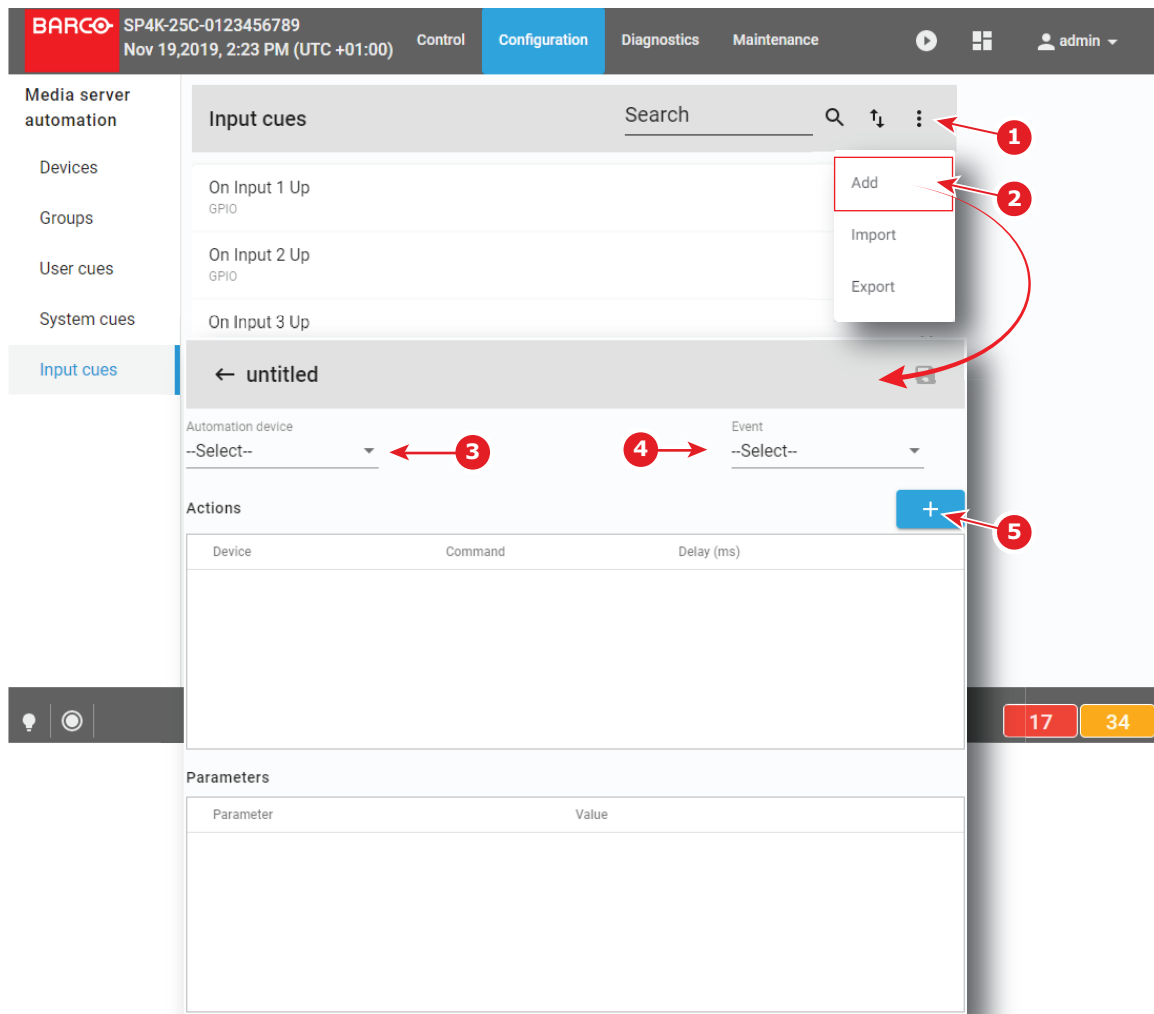

Image 11-26

An Untitled new Input Cue is created.

2. Select the automation device. Click on the drop down and select the device (reference 3).
3. Click on the drop down list and select the desired event (reference 4).
4. Click on the + to add an action for the selected device and event (reference 5).  
The event name becomes also the Input Cue name.
5. Click on the drop down box below *Device* and select an existing device that will execute the action (reference 6 and 7).



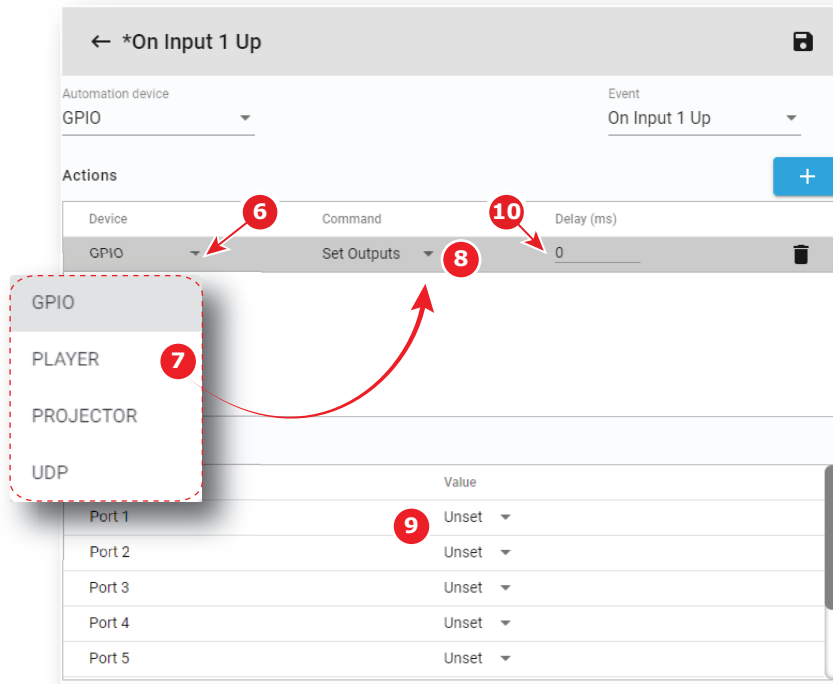

Image 11-27

By default there are four types of devices able to execute an action:

- **GPIO** (General Purpose Input/Output) : this device allows to interact with the 8 GPO outputs of the ICMP.
- **PLAYER**: Allows to access a set of commands tat will be sent to the ICMP Player.
- **PROJECTOR**: Allows to access the available projector macros.
- **UDP**: Allows to send text commands to devices.

Other devices can be added via the devices configuration page. For the complete list of devices and correlated commands, see “[Devices and commands](#)”, [page 242](#).

6. Click on the command drop down and select the desired command (reference 5). The command list changes depending on the selected device.

Some commands require additional parameters such as channel number or pulse duration for GPIO, the name of the macro to be executed by the projector. In all these cases, extra fields are displayed in the parameter pane (reference 9).

7. Enter a delay before a command is executed (reference 10).
8. Click the **Save** icon.

### How to remove an action?

1. While creating or editing an Input cue, click on the trash bin icon of the undesired action (reference 11).

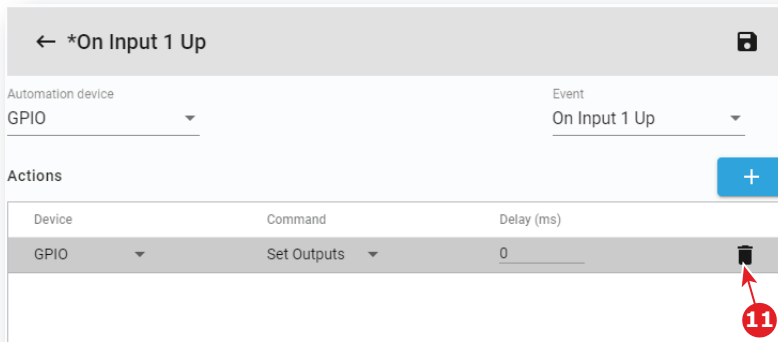

Image 11–28

The action is removed from the cue.

### 11.3.9 Edit an action in an Input Cue

#### Location & access

Menu: Media server automation > Input cues

Level : Administrator, Service technician

#### How to edit

1. While in *Configuration > Media sever automation > Input cues*, click on the cue to be edited.

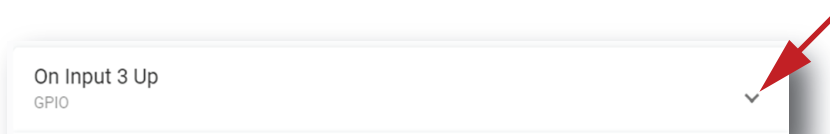

Image 11–29

The cue is displayed in expanded form.

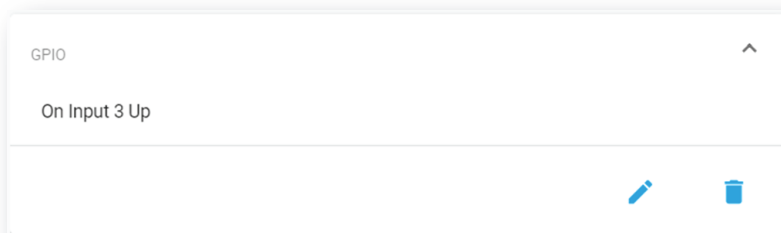



Image 11–30

2. Click on the **Edit** icon to open the action list. 

New actions can be added or existing actions can be updated following the same procedure as for a new input cue.

### 11.3.10 Export automation settings

#### Location & access

Menu: Media server automation > Input cues or User cues or System cues or Groups

Level : Administrator, Service technician

## What can be done

Cues and groups information can be downloaded into an XML file. The start can be in groups, user cues, system cues or input cues. The result will be the same.

## How to download

1. While in *Configuration > Media sever automation > Groups or Input cues, System cues or User cues*, click on the menu in the upper right corner (reference 1) and select **Export** (reference 2).

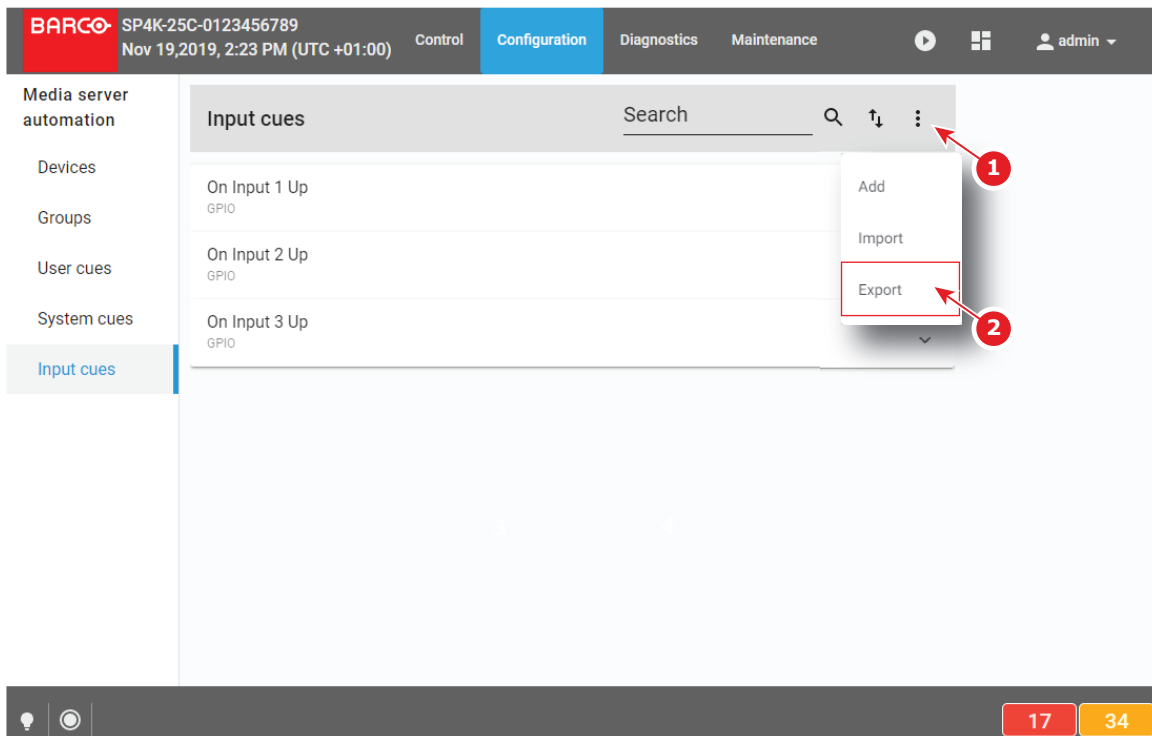

Image 11-31

An XML file called setting.xml is downloaded in your default download directory on your PC.

## 11.3.11 Import automation settings

### Location & access

Menu: Media server automation > Input cues or User cues or System cues or Groups

Level : Administrator, Service technician

### What can be done

Previously exported settings can be imported for reuse.

### How to import

1. While in *Configuration > Media sever automation > Input cues, System cues or User cues*, click on the menu in the upper right corner (reference 1) and select **Import** (reference 2).

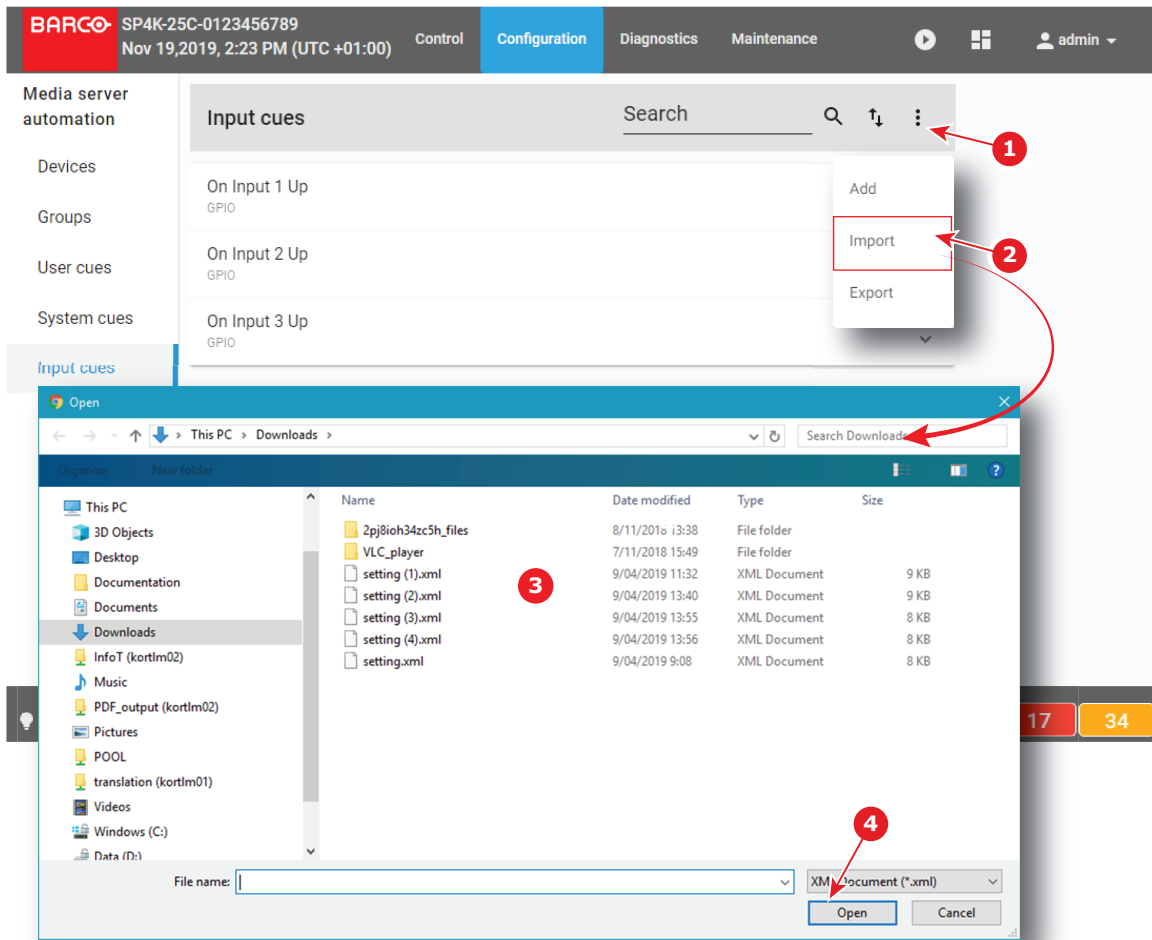

Image 11-32

A browser window opens.

2. Browse to the location of the cue settings file, select the file (reference 3) and click **Open** (reference 4). *Import configuration* panel is displayed.

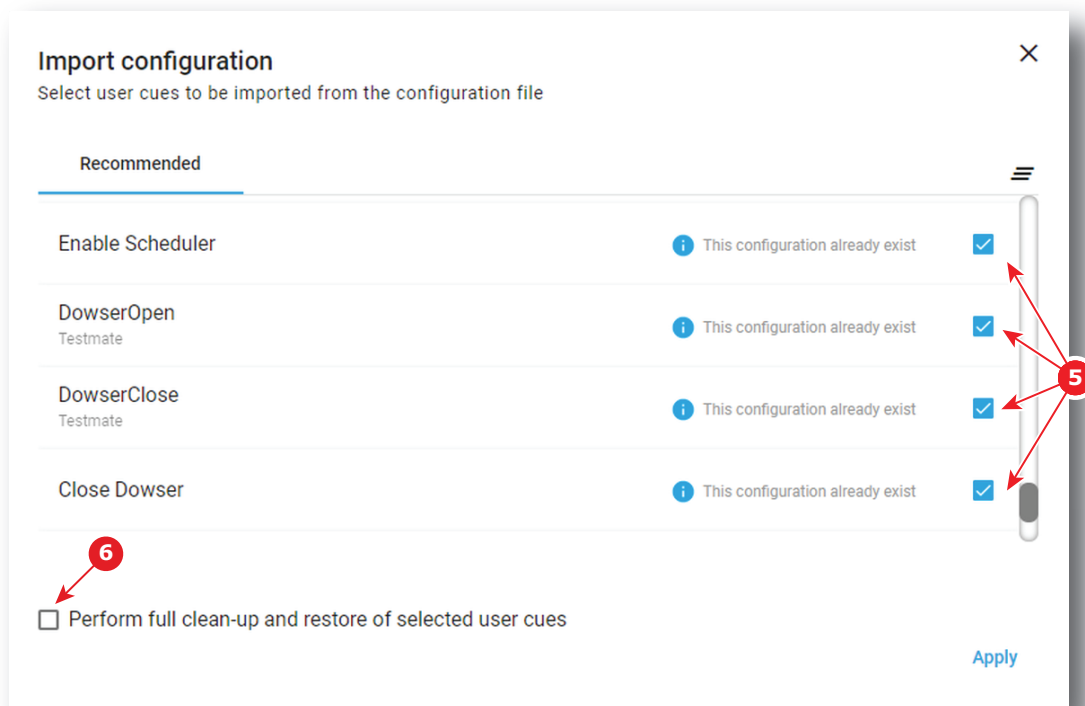

Image 11-33

3. Use check boxes (reference 5) to select (deselect) user cues to be imported from the configuration file.
4. Check **Perform full clean-up** (reference 6) to remove all groups, devices and actions already present before import new configuration.
5. Click **Apply** to import configuration.

Import is done according to the following rules

- if **Perform full clean-up** was checked, all actions, groups and devices already present are removed.
- if it already exist, a group is reused, else a new group is created.
- if it already exist, a device is reused, else a new device is created.



# Configuration - License and certificates

# 12

12.1	Managing licenses .....	256
12.2	Managing certificates .....	258
12.3	Projector registration.....	260

## About licenses and certificates

Licenses must be installed to play specific content types on media player or to use optional features. Device Identity Certificate, stored on the projector, is mandatory to activate some features which require an identification with another unit (e.g. link CLO). This chapter describes how to manage your licenses and certificates on the projector.

## 12.1 Managing licenses

### Location & access

Menu: Configuration > Licenses and certificates > Manage licenses

Level: Administrator

### Overview

All available licenses are listed in this menu. You can also use this menu to add or remove licenses.

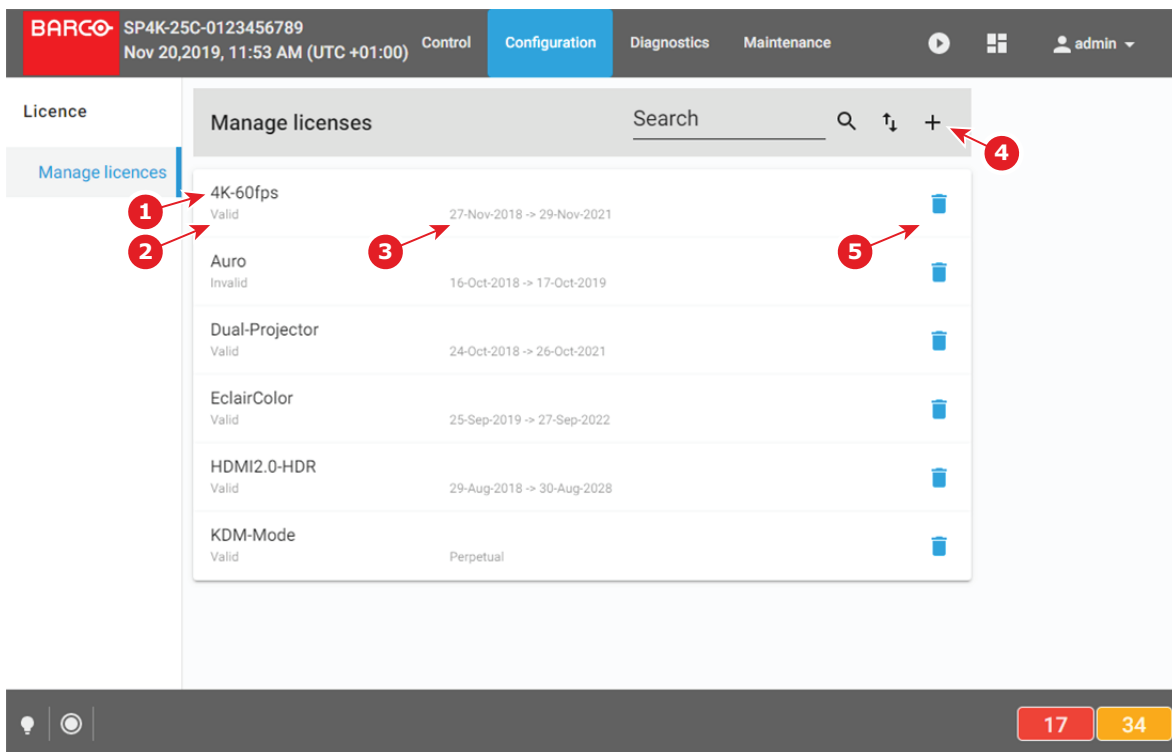

Image 12-1 Example of the Manage Licenses menu

A license file contains a name (reference 1) indicating the domain and/or a validity period (reference 3). Once the file is uploaded and checked the status of the license is indicated (reference 2).

Using the plus icon (reference 4), you can add new licenses. You can remove a license using the trash bin icon (reference 5).

### How to add a new license?

1. While in *Configuration > Licenses and certificates > Manage licenses*, click on the plus-icon (reference 1) to add a new license.



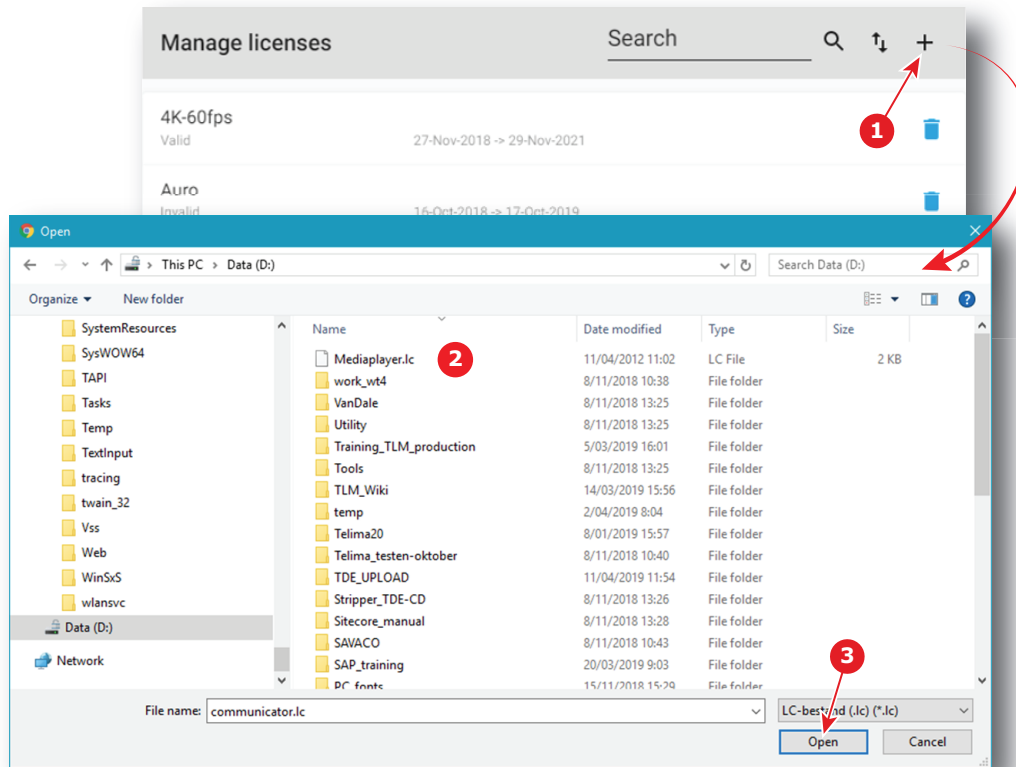

Image 12-2

A browser window opens.

2. Browse to the license file. The license file has the extension lc (reference 2).
3. Click **Open** (reference 3).

The license file is checked and uploaded to the projector. The new license will be added to the list of licenses and the status will be indicated.

### How to delete a license?

1. While in *Configuration > Licenses and certificates > Manage licenses*, click on the trash bin of the undesired license (reference 1).

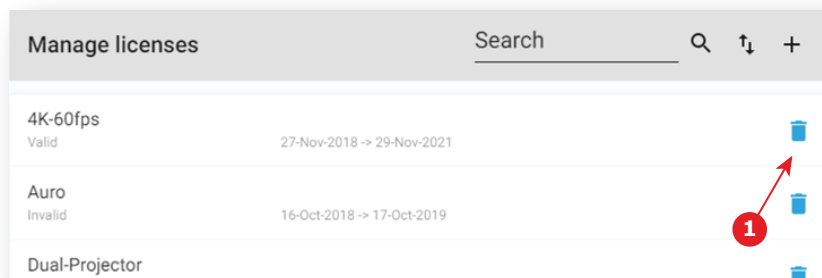

Image 12-3

The license is removed from the list.

## 12.2 Managing certificates

### Location & access

Menu: Configuration > Licenses and certificates > Manage certificates

Level: Administrator

### About certificates

There are several certificates available in this menu:

- **Projector identity certificate:** this certificate is used to digitally identify the projector. The projector certificate is used by example for the KDM generation. This certificate need to be signed by the Barco helpdesk.
- **HTTPS certificate:** This certificate (also called SSL certificate) is used to establish a secure connection to the WebCommunicator. This certificate need to be downloaded from the projector web site and manually installed on the user Web browser. For further details see [“Installing SSL certificate to enable HTTPS protocol”](#), page 50. Once the certificate is installed the HTTPS protocol is enabled and the future connections will be established automatically as long as the certificate is valid. This certificate has a limited life period (2 years max), this is the reason why a *renew* button is available to regenerate new certificate during periodic (programmed) maintenance operation. This certificate is based on parameters like the network configuration (e.g. Domain name) and need to be regenerate when these parameters change. This certificate need to be signed each time it is regenerate by a certificate authority (CA) to be valid.

### Overview

In most of the cases, when certificate uploaded during the projector building is still valid, certificate menu look like this:

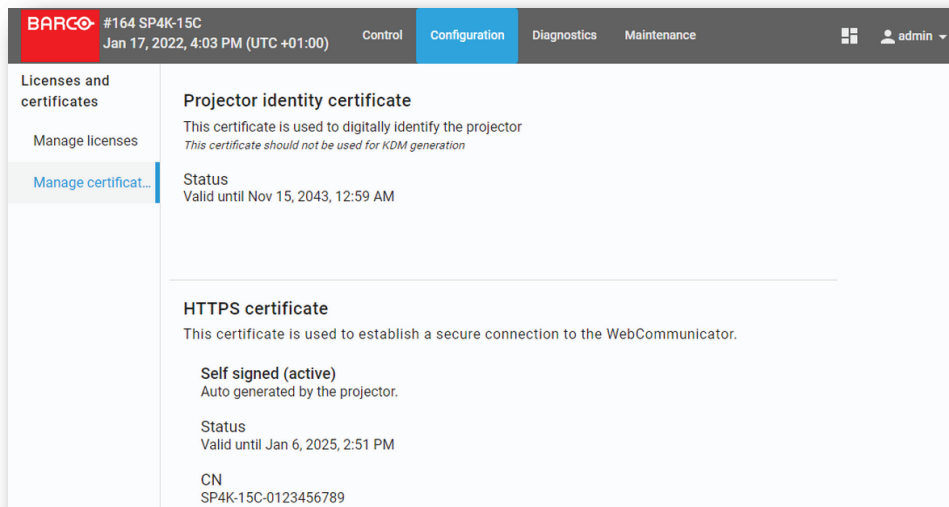

Image 12–4 Example of the Manage certificates menu with valid certificate

If device certificate is not valid or missing, certificate menu look like this:

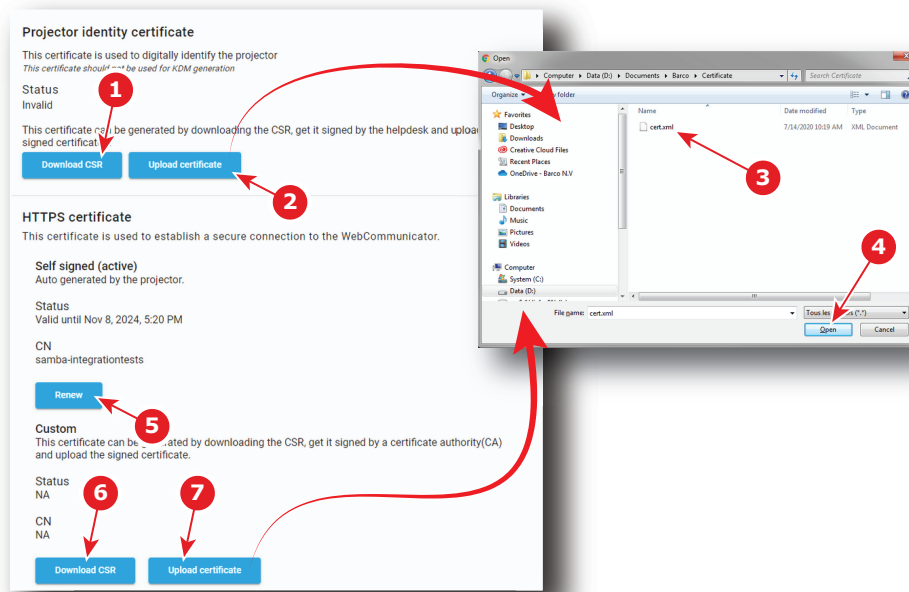

Image 12–5 Example of the Manage certificates menu with invalid certificate

In this case, follow the download procedure corresponding to the type of certificate you need.

### How to upload Projector identity certificate

1. While in *Configuration > Licenses and certificates > Manage certificates*, click on **Download CSR** (reference 1) to collect the certificate signing request (CSR).  
CSR file is created and automatically copied in the *Downloads* directory of your computer (e.g. *CertificateSigningRequest\_01234.gypVJX.xml*).
2. Send the CSR file to your Barco helpdesk to obtain the signed certificate corresponding to the projector.
3. When you received the certificate, click on **Upload certificate** (reference 2) to add it to the projector.  
A browser window opens.
4. Browse to the certificate file (reference 3). The certificate file has the extension xml (e.g. *cert\_01234.xml*).
5. Click **Open** (reference 4).  
The certificate file is checked and uploaded to the projector.

### How to renew and upload HTTPS (SSL) certificate

1. While in *Configuration > Licenses and certificates > Manage certificates*, click first on **Renew** (reference 5), then click on **Download CSR** (reference 6) to collect the certificate signing request (CSR).  
The CSR file is created and automatically copied in the *Downloads* directory of your computer (e.g. *CertificateSigningRequest\_01234.xml*).
2. Send this file to a Certificate authority (CA) to obtain the signed certificate corresponding to the information present in the CSR.
3. When you received the signed certificate, click on **Upload certificate** (reference 7) to add it to the projector.  
A browser window opens.
4. Browse to the certificate file (reference 3). The certificate file has the extension xml (e.g. *cert\_01234.xml*).
5. Click **Open** (reference 4).  
The certificate file is checked and uploaded to the projector.



Once the HTTPS certificate (SSL certificate) is correctly installed/valid, it can be downloaded from the projector web site and manually installed on the web browser of the user to establish a secure connection to the WebCommunicator. For further details see “[Installing SSL certificate to enable HTTPS protocol](#)”, page 50.

## 12.3 Projector registration

### Location & access

Menu: Configuration > Licenses and certificates > Projector registration

Level: Administrator

### Overview

If the projector is not activated, projector registration menu look like this:

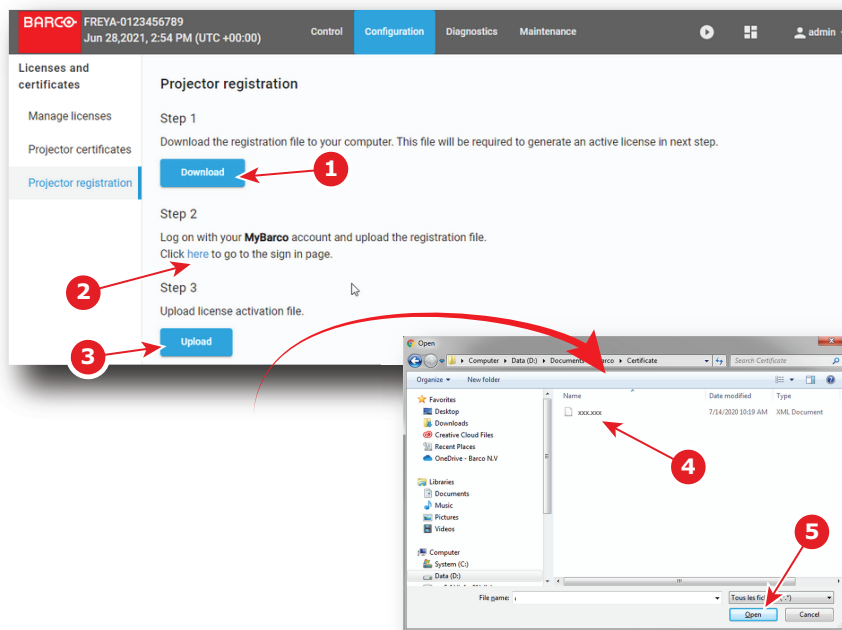

Image 12-6

Apply the next procedure to activate the projector.

### How to register a projector

1. While in *Configuration > Licenses and certificates > Projector registration*, click on **Download** (reference 1) to collect the registration file to your computer.  
Registration file is created and automatically copied in the *Downloads* directory of your computer (e.g. *registration\_0123456789.lic*).
2. Click **here** (reference 2) to reach the sign in page. Use your credentials to log you on MyBarco (<https://www.activate.barco.com/upload>)
3. Follow the procedure describes on MyBarco to activate your product (upload the Registration file collected in the first step, ...) and receive the license activation file corresponding to your projector.

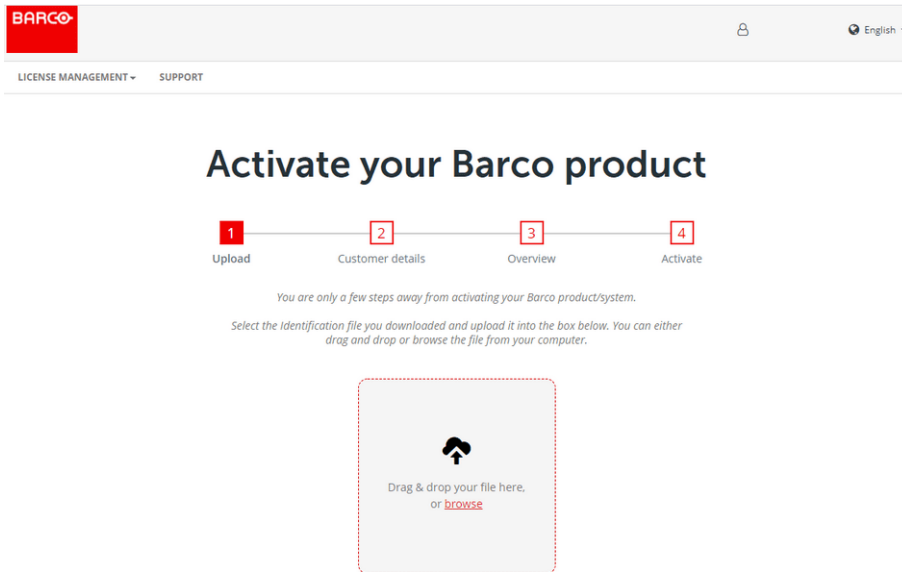

Image 12-7

4. When you received the license activation file, click on **Upload** (reference 3) to add it to the projector. A browser window opens.
5. Browse to the license activation file (reference 4). The license file has the extension `.lic`.
6. Click **Open** (reference 5).  
The license activation file is checked and uploaded to the projector.



# Configuration - Media server

# 13

13.1	Content.....	264
13.2	Player.....	270
13.3	Scheduler .....	271
13.4	Immersive sound .....	273
13.5	Audio channel .....	274

## About

These pages can be used to set all parameters of the ICMP-X (Integrated Cinema Media Processor) Media Server during installation or maintenance stages.

## 13.1 Content

### 13.1.1 About Content settings

#### Location & access

Menu: Configuration > Media server > Content

Level: Administrator, Service technician

#### Overview

This panel allows to manage connected content devices.

The content settings window allows to configure the list of servers, remote directories and libraries where the content is stored. All these assets will be called 'devices'.

Terms used in the server list.

**Content Device/Server name**    **Readable name of the remote device/server.**

Protocol	Protocol used for communication and transfer with the remote device / server: <ul style="list-style-type: none"> <li>• FTP: File Transfer Protocol</li> <li>• NFS: Network File System (for Unix like systems)</li> <li>• SMB: Server Message Block (for Windows and Unix like systems using Samba)</li> </ul>
IP/Hostname	IP address of the remote device/server in the theater network.
Port	Port number used for communication
Login	Login used by the ICMP-X to establish communication with the remote device.
Password	Password used by the ICMP-X to establish communication with the remote device.
Path/Remote path	Path where the contents are stored on the remote device/server.
Parameters	Parameters used by the ICMP-X to establish communication with the remote device.

### 13.1.2 Create a new content device

#### Location & access

Menu: Configuration > Media server > Content

Level: Administrator, Service technician

#### How to create

1. While in *Configuration > Media sever > Content*, click on the top right on the + (reference 1) to create a new device.



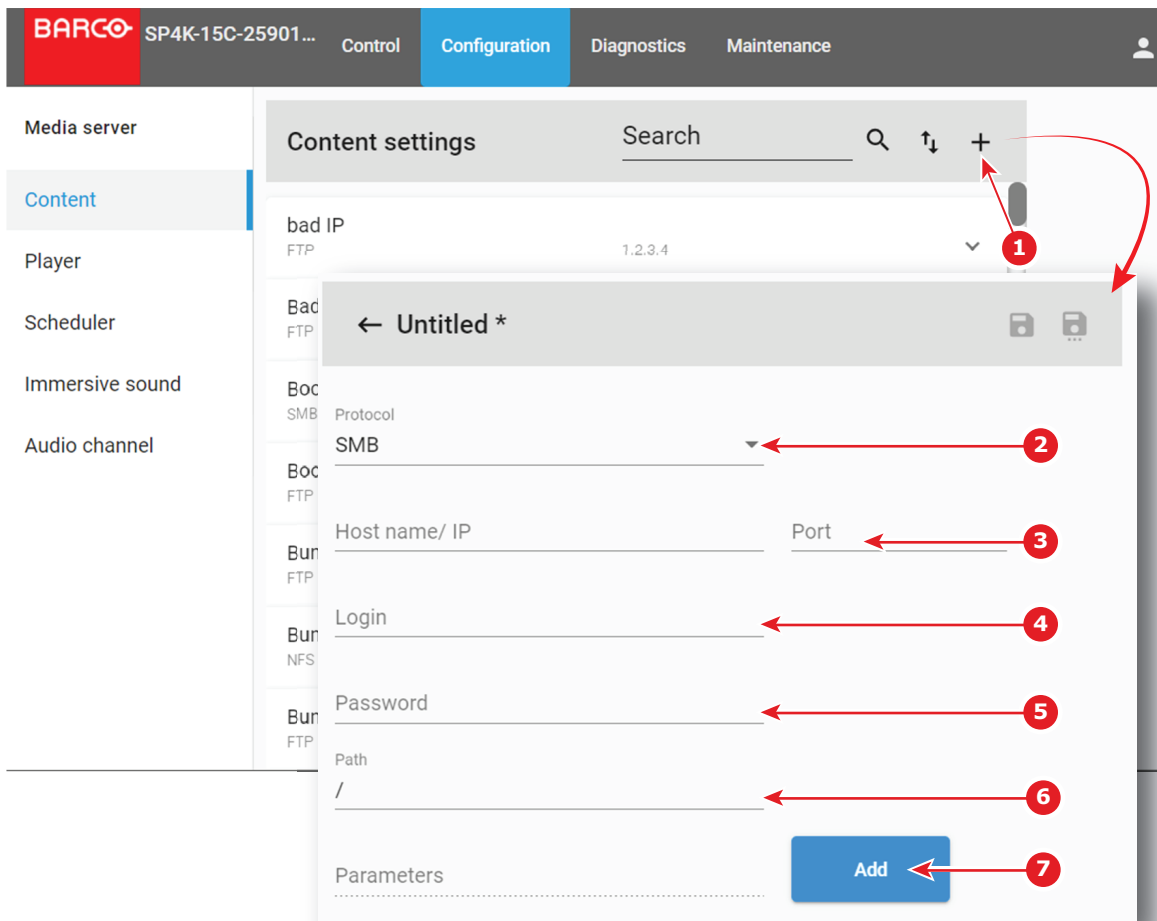

Image 13-1

A new untitled content is displayed.

2. Select a *protocol* by clicking on the drop down list (reference 2).

The following protocols can be used for communication and transfer with the remote device

- FTP: File Transfer Protocol
- NFS: Network File System (for Unix like systems)
- SMB: Server Message Block (for Windows and Unix like systems using Samba)

3. Fill out the *host name* or *IP address* and corresponding *port number* (reference 3).
4. Provide the *login* to establish the communication with the remote device (reference 4).
5. Enter the *password* used to establish the communication with the remote device (reference 5).



**Note:** Do not use one of the following characters in the login and password: /, : or @.

6. Enter the *path* to the content on the remote device (reference 6).
7. When requested, enter the necessary parameters. Click **Add** to open the parameter selection menu with default values (reference 7).

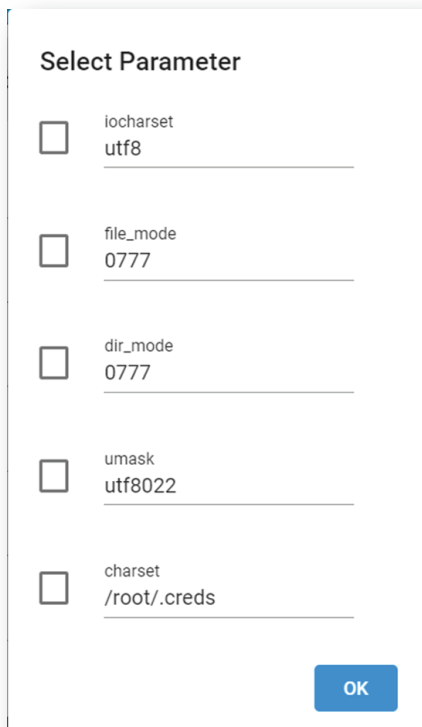

Image 13-2

A selection can be made out of the following parameters:

- iocharset
- file\_mode
- dir\_mode
- umask
- charset

Check the check box in front of the desired parameter. To change a value, select the current value and enter the new value.

8. Optional: click **Test** (bottom of the new created content) to directly test connection with the content device.

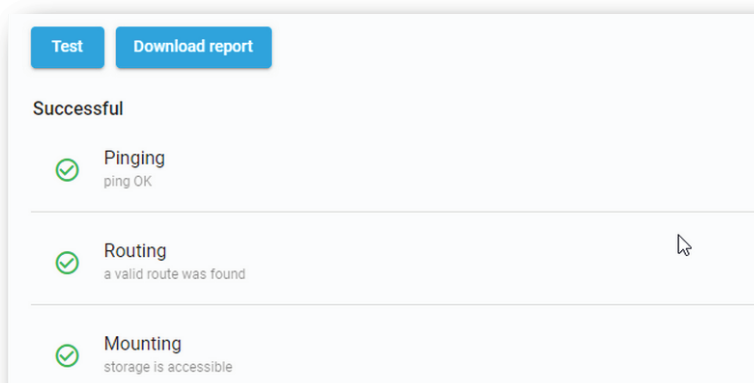

Image 13-3

After few moment connection status is displayed and **Download report** button is available near the **Test** button.

9. Optional: Click **Download report** allows to download a text file with the result of the test connection on your local PC in your default download directory.

**Example**

```
ping 172.30.82.221 -c 3 >
PING 172.30.82.221 (172.30.82.221): 56 data bytes>
64 bytes from 172.30.82.221: seq=0 ttl=64 time=0.970 ms>
64 bytes from 172.30.82.221: seq=1 ttl=64 time=0.449 ms>
64 bytes from 172.30.82.221: seq=2 ttl=64 time=0.400 ms>
>
--- 172.30.82.221 ping statistics --->
3 packets transmitted, 3 packets received, 0% packet loss>
round-trip min/avg/max = 0.400/0.606/0.970 ms>
TEST-STEP - Pinging - Success - ping OK>
>
ip route get 172.30.82.221 >
172.30.82.221 dev eth0 src 172.30.82.135 >
TEST-STEP - Routing - Success - a valid route was found>
>
curlftpfs -o connect_timeout=10 -o allow_other barco:123456@172.30.82.221:21/AURO >
139 directories and 6 files found at root path>
>
TEST-STEP - Mounting - Success - storage is accessible>
```

10. Click **Save As** to display the **Save As** window.

Enter a name and click **Save**.

### 13.1.3 Modify a content device

#### Location & access

Menu: Configuration > Media server > Content

Level: Administrator, Service technician

#### How to edit

1. While in *Configuration > Media sever > Content*, click on the content device that you need to modify.

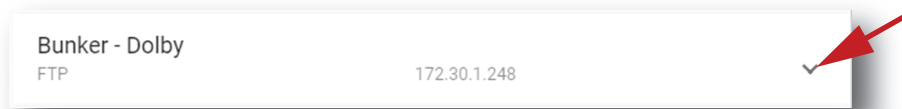

Image 13-4

The content device is displayed in its expanded form with a menu.

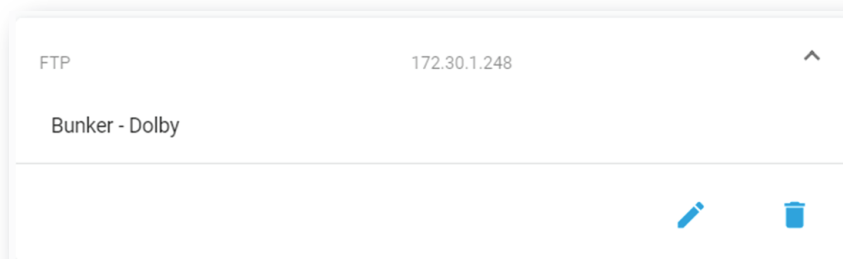



Image 13-5

2. Click **Edit** in the menu. 
- The Content settings are displayed (reference 1).
3. Modify the necessary fields.

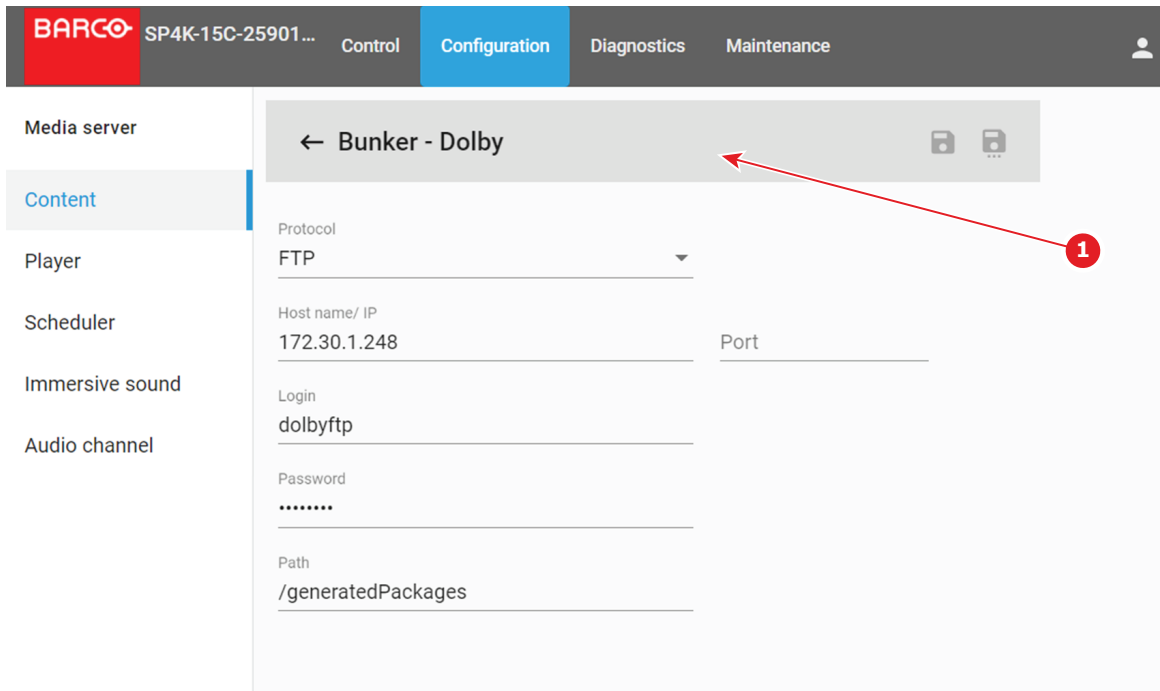

Image 13-6

The device name is marked with an asterisk if at least one field is modified.

- Optional: click **Test** (bottom of edited content) to directly test connection with the content device.

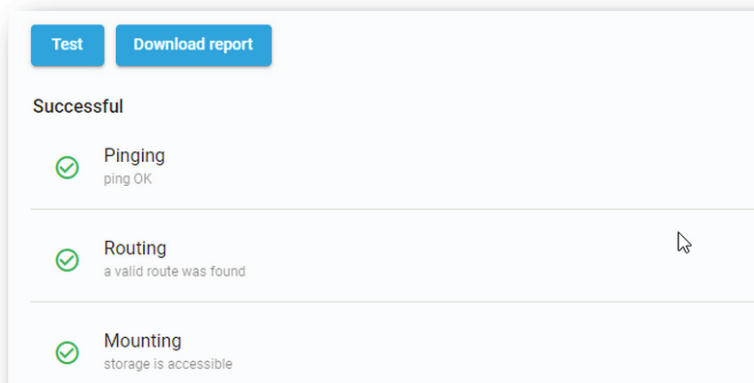

Image 13-7

After few moment connection status is displayed and **Download report** button is available near the **Test** button.

- Optional: Click **Download report** allows to download a text file with the result of the test connection on your local PC in your default download directory.

**Example**

```
ping 172.30.82.221 -c 3 >
PING 172.30.82.221 (172.30.82.221): 56 data bytes>
64 bytes from 172.30.82.221: seq=0 ttl=64 time=0.970 ms>
64 bytes from 172.30.82.221: seq=1 ttl=64 time=0.449 ms>
64 bytes from 172.30.82.221: seq=2 ttl=64 time=0.400 ms>
>
--- 172.30.82.221 ping statistics --->
3 packets transmitted, 3 packets received, 0% packet loss>
round-trip min/avg/max = 0.400/0.606/0.970 ms>
TEST-STEP - Pinging - Success - ping OK>
>
```

```

ip route get 172.30.82.221 >
172.30.82.221 dev eth0 src 172.30.82.135 >
TEST-STEP - Routing - Success - a valid route was found>
>
curlftpfs -o connect_timeout=10 -o allow_other barco:123456@172.30.82.221:21/AURO >
139 directories and 6 files found at root path>
>
TEST-STEP - Mounting - Success - storage is accessible>

```

6. Click **Save** (reference 4) to update the modifications in the device list

or

click **Save as** (reference 5) to save the modifications with a new device name.



Image 13-8

To return with saving the modifications, click on the return arrow (reference 2).

### 13.1.4 Delete a content device

#### Location & access

Menu: Configuration > Media server > Content

Level: Administrator, Service technician

#### How to delete

1. While in *Configuration > Media sever > Content*, click on the content device that you need to delete.

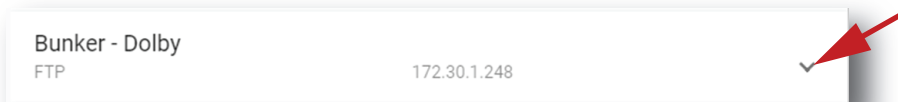

Image 13-9

The content device is displayed in its expanded form with a menu.

2. Click on the trash bin icon to delete.

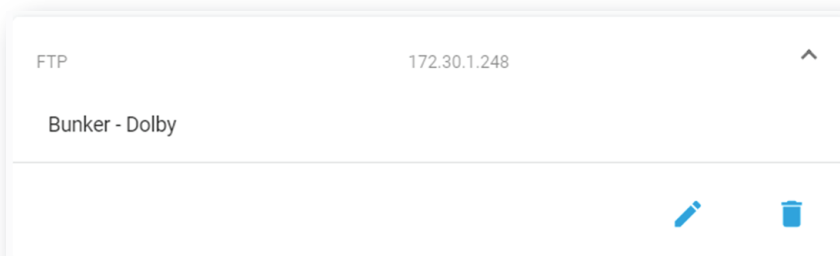

Image 13-10

The selected content device is removed from the list.

## 13.2 Player

### 13.2.1 About Player settings

#### Location

Configuration > Media server > Player

#### Overview

Audio delay (ms)	Audio delay is used to correct the synchronization between sound and picture. This delay can be positive or negative.
Audio output frequency (kHz)	Allows to set the sound frequency (48 KHz- 96 KHz) for the audio output. The default value is 48 KHz
SMPTE Sync delay	<p>The <i>SMPTE Sync delay (ms)</i> (used for APX, but also 4D) is grayed out when SMPTE sync is not mapped to an AES output.</p> <p>this SMPTE sync delay setting goes hand in hand with the AES output configuration (where you assign the SMPTE sync signal to a AES channel)</p> <p>The “audio delay” and “SMPTE sync delay” are combined in the backend to an added-up value. When using both, take care that the sum is correct (equal to the intended external value)</p> <p>The input field accept values so that:</p> <ul style="list-style-type: none"> <li>• sum of both delay values (audio delay and SMPTE sync delay) <math>\geq -500</math> ms and <math>\leq 200</math> ms</li> <li>• SMPTE delay settings <math>\leq 0</math></li> </ul>

### 13.2.2 Modifying the player settings

#### Location & access

Menu: Configuration > Media server > Player

Level: Administrator, Service technician

#### How to modify

1. While in *Configuration > Media sever > Player*, click on the audio delay input field and enter the desired delay (reference 1).

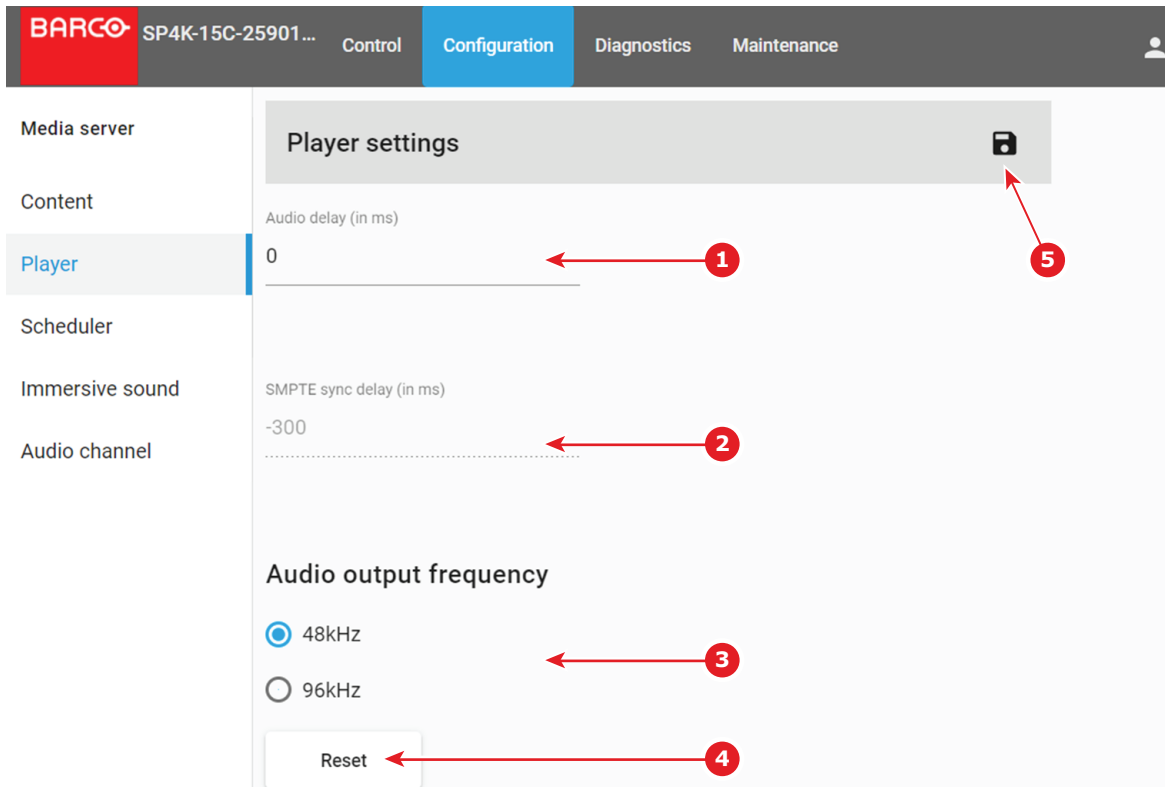

Image 13–11

2. To modify the *SMPTE Sync delay*, click on the *SMPTE Sync delay* input field and enter the desired value (reference 2).
3. Select the *Audio output frequency* by clicking on the desired radio button (reference 3).
4. Click **Reset** to return to the default values (reference 4).
5. Click the **Save** button to save the player settings (reference 5).

## 13.3 Scheduler

### 13.3.1 About scheduler settings

#### Location

Configuration > Media server > Scheduler

#### Overview

Scheduler at startup	<p>The state of the scheduler when starting the projector.</p> <ul style="list-style-type: none"> <li>• Enabled : the player is controlled by the scheduler → Scheduler mode</li> <li>• Disabled : the player is manually controlled → Manual mode</li> </ul> <p>Default value : Enable</p>
Maximum delay allowed (in mins)	<p>Maximum delay allowed for which the ICMP-X will attempt to start a scheduled show from its scheduled start time. This will be used in case the content player is busy and cannot start the show at the scheduled time.</p> <p>Default value : 10 minutes.</p>
Preselection delay (in mins)	<p>Based on this value, the ICMP-X will attempt to select a scheduled show in advance for the given values. If the Player is busy, the ICMP-X shall retry the show selection every minute from then.</p> <p>Default value : 30 minutes</p>

History length (in days)	Length of the schedule history. Scheduled shows older than that value are automatically deleted. Default value : 30 days
Maximum play trigger delay (in seconds)	Allow to delay the start of a scheduled show. Default value: 0 seconds
Dark screen detection delay (in seconds)	Delay between the dark screen detection and the start of the actions to be done when a dark screen is detected.

### 13.3.2 Modify the scheduler settings

#### Location & access

Menu: Configuration > Media server > Scheduler

Level: Administrator, Service technician

#### How to modify

1. While in *Configuration > Media sever > Scheduler*, check or uncheck the check box in front of *Enable scheduler at startup* (reference 1).
  - When checked: the player is controlled by the scheduler, scheduler mode.
  - When not checked: the player is manually controlled, manual mode.

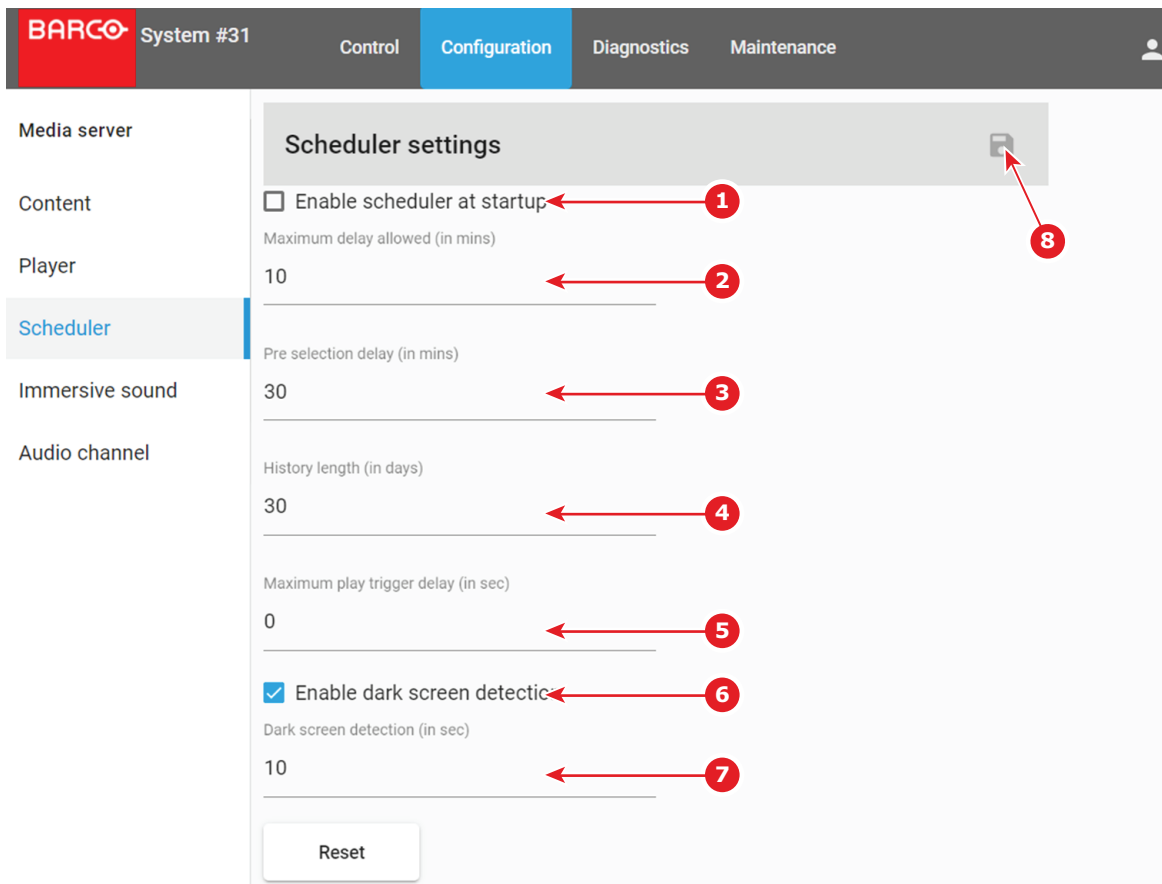

Image 13-12

2. To change the maximum allowed delay or the pre selection delay, select the current value and enter a new value (reference 2 or 3)
3. To change the history length, select the current value and enter a new value (reference 4)
4. To change the maximum play trigger delay, select the current value and enter a new value (reference 5)



5. To activate the Dark Screen detection, check the check box in front of *Dark Screen detection* (reference 6). Change the delay setting, using the up down control or enter a new value in the input field (reference 7).
6. Click the Save button to save the scheduler settings (reference 8).  
Or click reset to return to the default value.

### About the Dark screen detection

When a dark screen is detected, scheduled actions can be started after a certain delay time.

The dark screen error is reported in the logging with the following message : “unexpected behavior : no image”

The dark screen detection applies to any input that is currently selected and playing (in or out of a show).

The error is reported when the following conditions are combined :

- The player is in scheduled mode
- The dark screen trigger is active in the scheduler settings
- A CPL (composition playlist) is playing (or paused) OR an alternative input is selected
- The projector light source is off (or ICMP output remains black) for at least the amount of seconds configured in the Schedule settings

The error is not reported :

- when playing a black clip from ICMP special clips.
- on a slave projector except if that slave is playing in standalone mode.
- when a delay is automatically added to sync a 3D system.

## 13.4 Immersive sound

### Location & access

Menu: Configuration > Media server > Immersive sound

Level: Administrator, Service technician

### About immersive sound

As there are different audio processors in the market, some typical configurations must be done.

The audio processor should be configured by adding its IP address and activating the function in Web Communicator. The protocol for the audio processor should be selected. Once all these actions are done, the audio processor can be used in Web Commander.

### How to setup and activate

1. While in *Configuration > Media sever > Immersive sound*, enter the IP address/hostname of the immersive sound input of the audio processor (reference 1).



*Tip:* Click **Reset** (reference 6) to return to the default values.

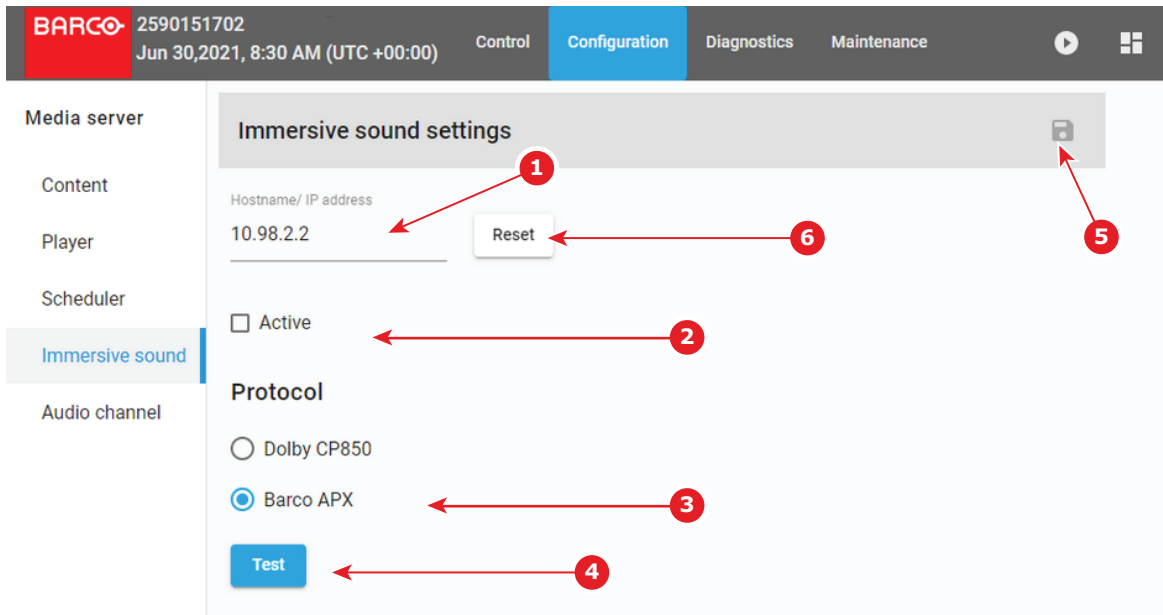

Image 13-13

2. To activate, check the check box in front of *Active* (reference 2).  
Checked: activated.  
Unchecked: deactivated.
3. Select the audio processor protocol (reference 3). Click on the desired radio button.  
When an APX AuroMax® processor is used, select the *AuroMax* protocol.  
When an Dolby Atmos processor is used, select the *Dolby Atmos* protocol.
4. **Test** (reference 4) can be used to check communication between the media server and the audio processor. After few seconds, once the test is done, the result is displayed under the test button. The status of the test (e.g. **Successful**) and some details like downstream speed (ping test) or connection test are available. **Download report** button is also displayed. Use this button to create and download a report of the test on your local PC in your default download directory.
5. Click the Save button to save the immersive sound settings (reference 5).

## 13.5 Audio channel

### 13.5.1 About audio channel configuration

#### Location & access

Menu: Configuration > Media server > Audio channel

Level: Administrator, Service technician

#### Overview

The audio content in digital cinema is a multichannel sound system which can produce spatial sound signals to reproduce a sense of realism. Each channel is dedicated to a specific speaker.

The audio channel page allows to map the audio channels (content) on the audio output (AES outputs of the ICMP-X).

Within the content, audio channels are identified by labels (e.g. L, R, C...) according to predetermined standards (SMPTE 5.1, SMPTE 6.1 ...), or by default labels (CH01, CH02 ...). To assign an audio channel to an AES audio output, the desired label must be added to the output channel.

The ICMP-X has 16 AES audio output channels but all outputs must be activated. An optional attribute is used to indicate whether the AES output channel is physically connected or not. This is currently mainly informative for technicians.

Several standards are available by default including Auro and AuroMax.

## 13.5.2 Modify the audio channels

### Location & access

Menu: Configuration > Media server > Audio channel

Level: Administrator, Service technician

### How to modify

1. While in *Configuration > Media sever > Audio channel*, select the channel standard by clicking on the drop down list next to *Channels* (reference 1).

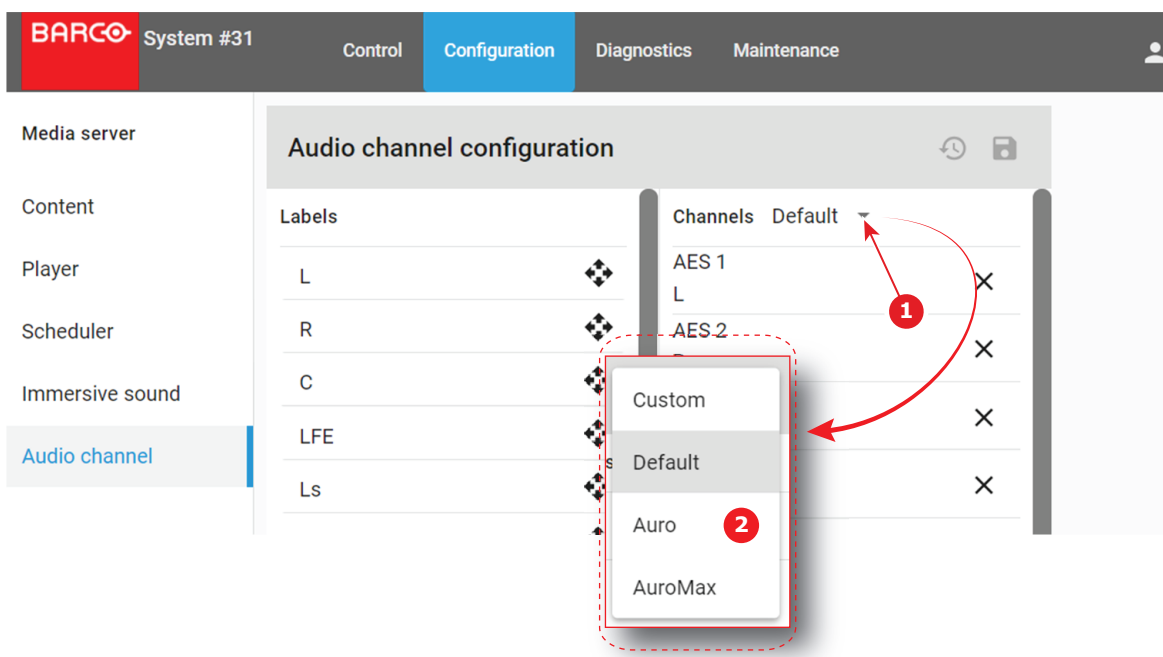

Image 13-14

The following options are possible:

- *Default*: default channel configuration as standard channel mapping. These mapping is only changed in rare occasions or for troubleshooting reasons.
- *Auro*: channel configuration for the Auro standard.
- *AuroMax*: channel configuration for the AuroMax standard.
- *Custom*: channels can be configured by the customer.

2. Click and drag the desired label on to the desired channel (reference 1 and 2).

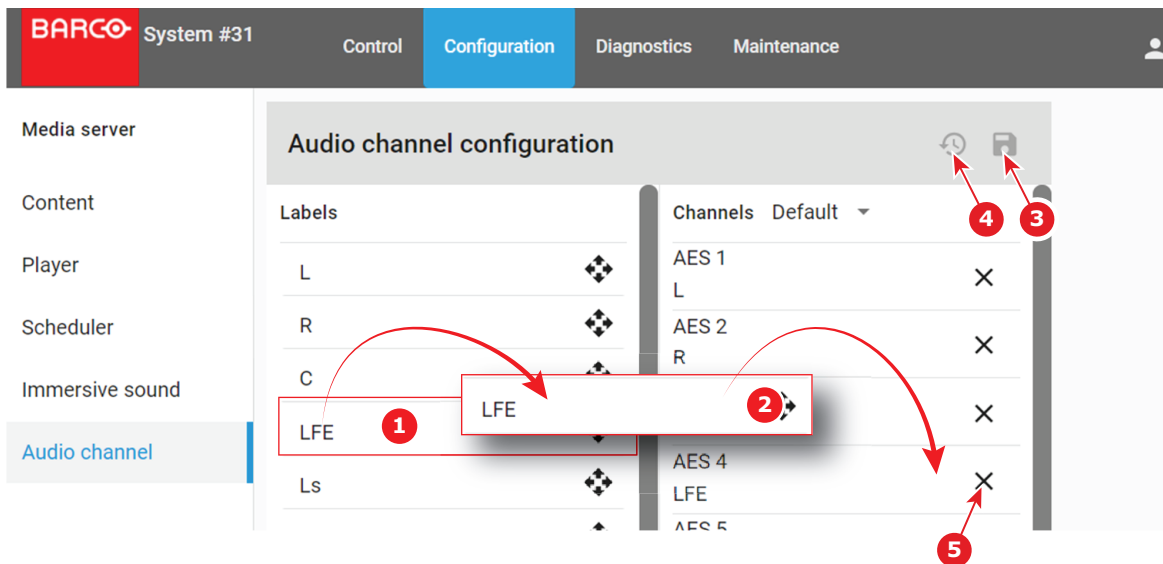

Image 13–15

3. Continue until all channels get a label.
4. Click **Save** button to save the audio channel configuration (reference 3).  
Click **Discard** button to undo all changes (reference 4).
5. To delete a label from a channel, click on the **delete** button (reference 5)

# Configuration - System access

# 14

14.1	Network configuration .....	278
14.2	User management .....	285
14.3	Marriage pin code .....	290
14.4	SNMP .....	294
14.5	Multi projectors .....	298

## About this menu

System access menu allows you to set all the parameters related to system configuration (name, network settings) and user management.

## 14.1 Network configuration

### 14.1.1 About network configuration

#### Location & access

Menu: Configuration > System access> Network configuration

Level: Administrator, Service technician

#### Overview

This panel is used to define the network configuration of the projector and, when present, the network configuration of the mediablock. Click on the network interface you want to set in the list (reference 1).

When the projector network interface (reference 2) is displayed, modify the auditorium name (reference 3) and configure the network.

A switch (reference 4) allows to choose the setting mode. Two configuration modes are available: Automatic or Manual.

In manual mode, parameters (reference 7) are editable and must be adjusted manually.

In automatic mode, DHCP (Dynamic Host Configuration Protocol) server provides settings which will be applied to the projector's network configuration. Network parameters (reference 7) are not editable (greyed out).

Host name (reference 5) and Domain (reference 6) are editable in both cases.



The host name is the name given to the projector in the local network and will be used to identify it over DNS if that is configured. Domain is the name given to the local network. It will be required to reach the local network from an external point (like the Internet).

If you were trying to connect to the projector from external point, you need address it by using its IP address or with its full name (e.g. hostname.domain.com). It is preferable to use the second method to address a projector because the IP address can sometimes change (e.g. when the assignment of the IP address is automatically managed by a DHCP server).

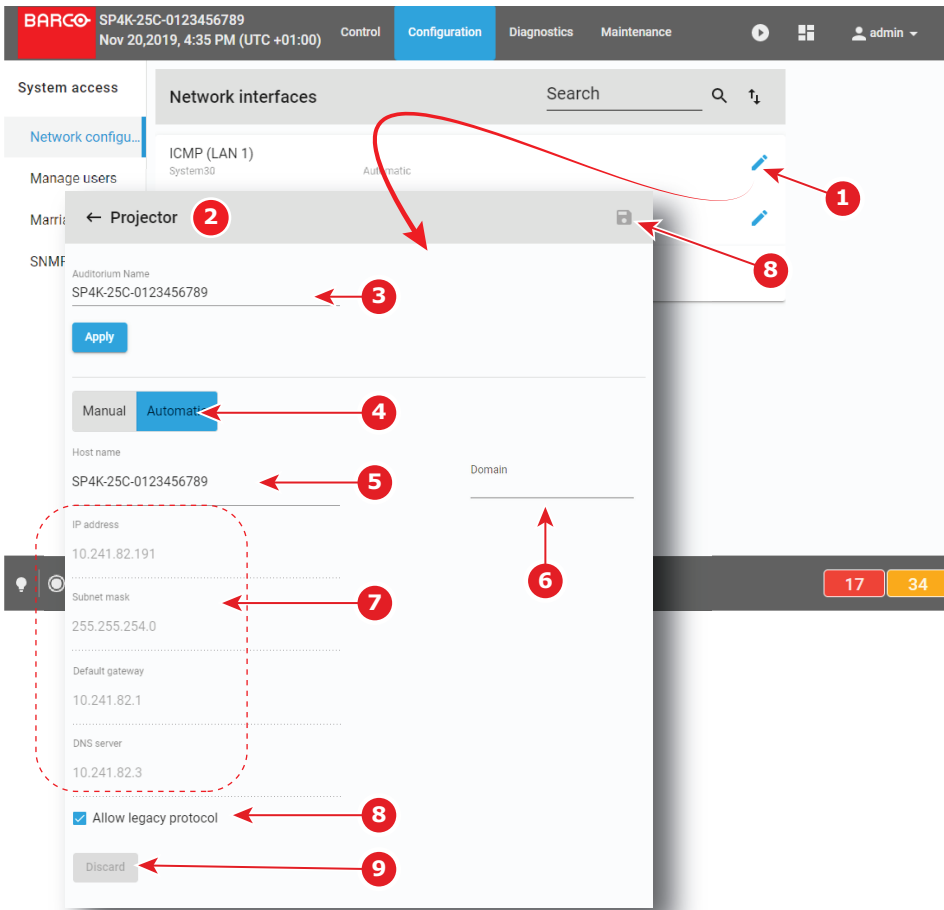

Image 14–1

**Allow legacy protocol** check box (reference 6) must be activated when a third party equipment need to send API over Ethernet commands to the projector using the legacy protocol as used on Series 2 projectors. A third party equipment could be a TMS, an automation device, an IMB/IMS installed in the projector or any other equipment which need to operate the projector. The commands available are controlling the basic features of the projector such as Light ON/OFF, Dowser Open/Close, Execute Macro...

**Discard** button (reference 7) allows to restore last configuration (removing unsaved user modifications).

**Save** button (reference 8) allows to save modifications.

## Ethernet Connections

Ethernet is a networking technology commonly used to communicate with local area network (LAN) and wide area network (WAN). This protocol requires an IP address, Subnet-mask, default gateway and DNS server address.

These parameters can be automatically applied from DHCP server or need to be adjusted manually.



### IP

Internet Protocol. The network layer of TCP/IP. Required for communication with the internet.



A new projector is delivered with a default IP address : 192.168.100.2



### Subnet mask

A number that is used to identify a subnetwork so that IP addresses can be shared on a local area network.



### Default Gateway

A router that serves as an entry point into and exit point out of a network. For example, a local network (LAN) may need a gateway to connect it to a wide area network (WAN) or to the Internet.



### DNS server

Computers, Projectors, Touch panels connected to a network are referenced by their IP address. The only problem is that remembering IP addresses is not easy. If you need to use hundreds of addresses then it will become impossible to remember them. This is why domain names are created. Internet names (domain and host names) are just aliases to these IP addresses. When you use an Internet address it is automatically translated to an IP address. In fact a program or device that translates those Internet names to IP addresses is called a DNS Server.



### Host name

This is the name that will be returned, along with the IP address in response to the UDP broadcast query for projectors/touch panels.



### DHCP

Dynamic host configuration protocol. DHCP is a communications protocol that lets network administrators manage centrally and automate the assignment of IP addresses in an organization's network. Using the Internet Protocol, each machine that can connect to the Internet needs a unique IP address. When an organization sets up its computer users with a connection to the Internet, an IP address must be assigned to each machine. Without DHCP, the IP address must be entered manually at each computer and, if computers move to another location in another part of the network, a new IP address must be entered. DHCP lets a network administrator supervise and distribute IP addresses from a central point and automatically sends a new IP address when a computer is plugged into a different place in the network.



### UDP

User Datagram Protocol

## 14.1.2 Assigning an auditorium name to the projector

### Location & access

Menu: Configuration > System access > Network configuration

Level: Administrator, Service technician

### How to set up auditorium name

1. While in *Configuration > System access > Network configuration*, click on the edit icon of **Projector**

(reference 1).



Projector network interface (reference 2) is displayed



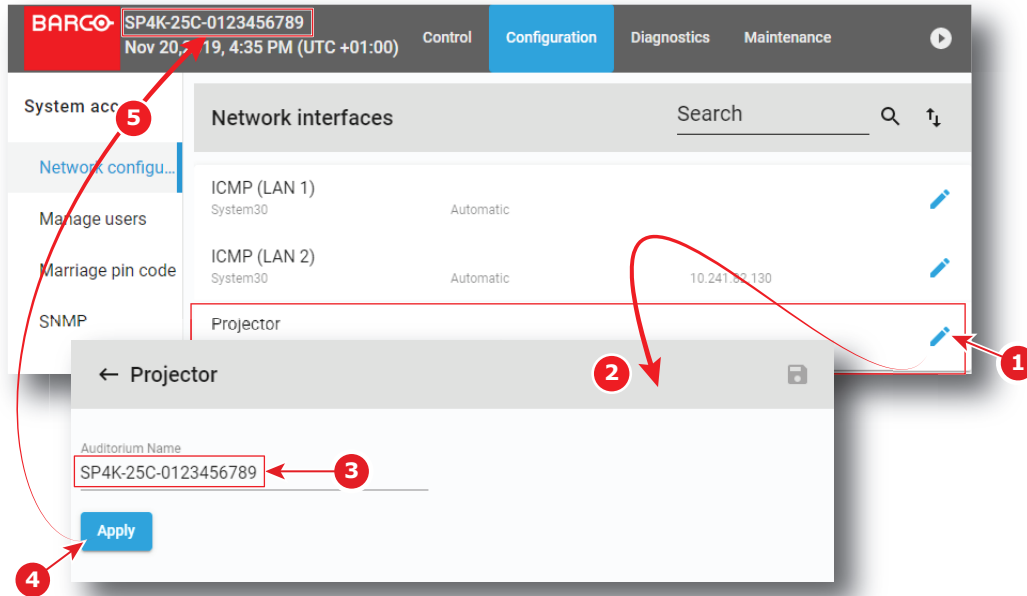

Image 14-2

- Click in the input field of the *Auditorium name* (reference 3) to enter the desired name, then click **Apply** (reference 4).

New Auditorium name is active now and displayed in menu bar (reference 5).



When the Auditorium name has been entered correctly, it is always available in the menu bar near the Barco logo, even when you are not logged in.

### 14.1.3 Assigning a host name and a domain to the projector

#### Location & access

Menu: Configuration > System access > Network configuration

Level: Administrator, Service technician



Change the host name or domain of the projector result in the automatic creation of a new SSL certificate. This new certificate need to installed by the users in their own browsers to enable the HTTPS protocol and establish secure connections. For more details see [“Installing SSL certificate to enable HTTPS protocol”](#), page 50.

#### How to set up host name or domain

- While in *Configuration > System access > Network configuration*, click on the *edit* icon of the projector interface.

The projector network interface is displayed.

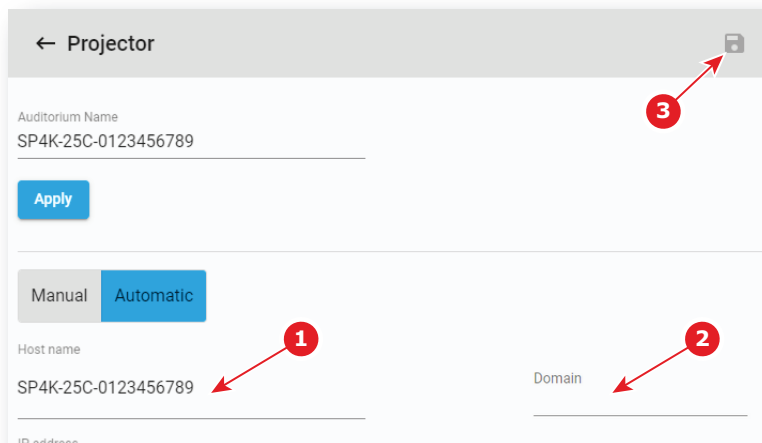



Image 14–3

2. Select the *Host name* (reference 1) and enter the desired name.

 **Note:** Host name may contain only the ASCII letters 'a' through 'z' (in a case-insensitive manner), the digits '0' through '9', and the minus sign ('-').

To indicate that projector parameters are being edited an *asterisk* is displayed and the **Save** icon (reference 3) is now enabled.

or

Select the *Domain* (reference 2) and enter the desired domain name.

To indicate that projector parameters are being edited an *asterisk* is displayed and the **Save** icon (reference 3) is now enabled.

3. Click **Save** (reference 3).

A confirmation window appears.

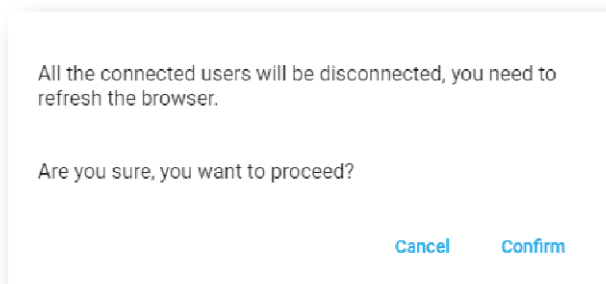

Image 14–4

4. Click **Confirm**.

Network service restarts (all connected users are disconnected from the projector) then, after few moments, login page is displayed.

or

Click **Cancel**.

The confirmation window closes and modification is canceled.

## 14.1.4 Assigning a network address

### Location & access

Menu: Configuration > System access> Network configuration

Level: Administrator, Service technician



The projector has been configured as receiving an IP address automatically. This means that by default you should not have to configure anything. However, if the projector can not find an appropriate DHCP server on the network, or if the projector is not connected to any network in general, the projector will trigger an error instead.



If you are unsure on what IP address, subnet mask or default gateway address the projector should receive, please contact your local network administrator.

## How to set up automatically

1. While in *Configuration > System access > Network configuration*, click on the *edit* icon of the projector

interface. 

The projector network interface is displayed.

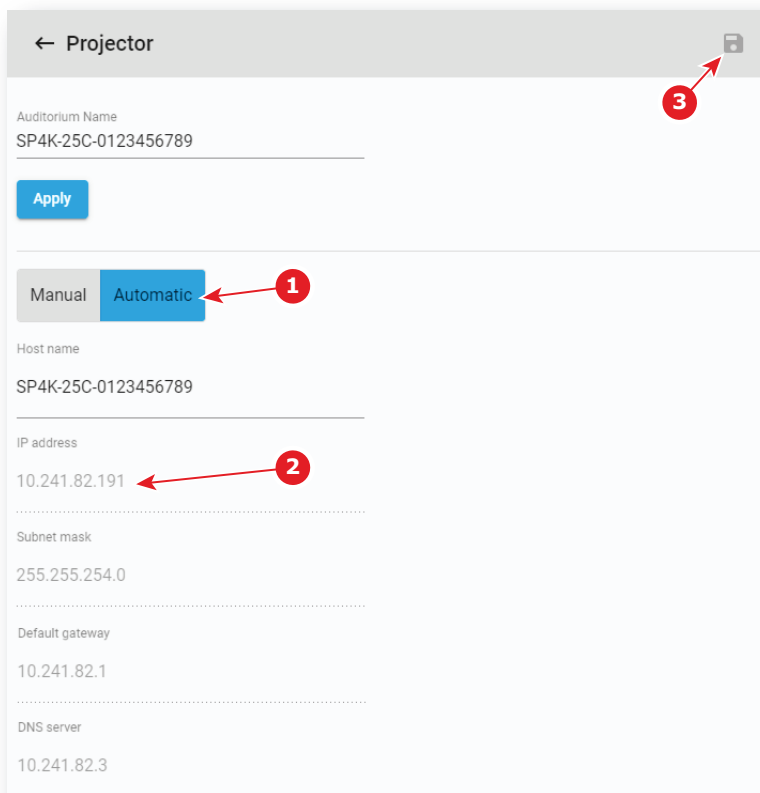

Image 14–5

2. If not already active, click **Automatic** (reference 1).  
Configuration provided by DHCP server becomes active:
  - new settings (IP Address, Subnet mask, ...) replace the previous network configuration parameters.
  - network configuration parameters are greyed out.
3. Click the save icon.

## How to set up manually

1. While in *Configuration > System access > Network configuration*, click on the *edit* icon of the projector

interface. 

The projector network interface is displayed.

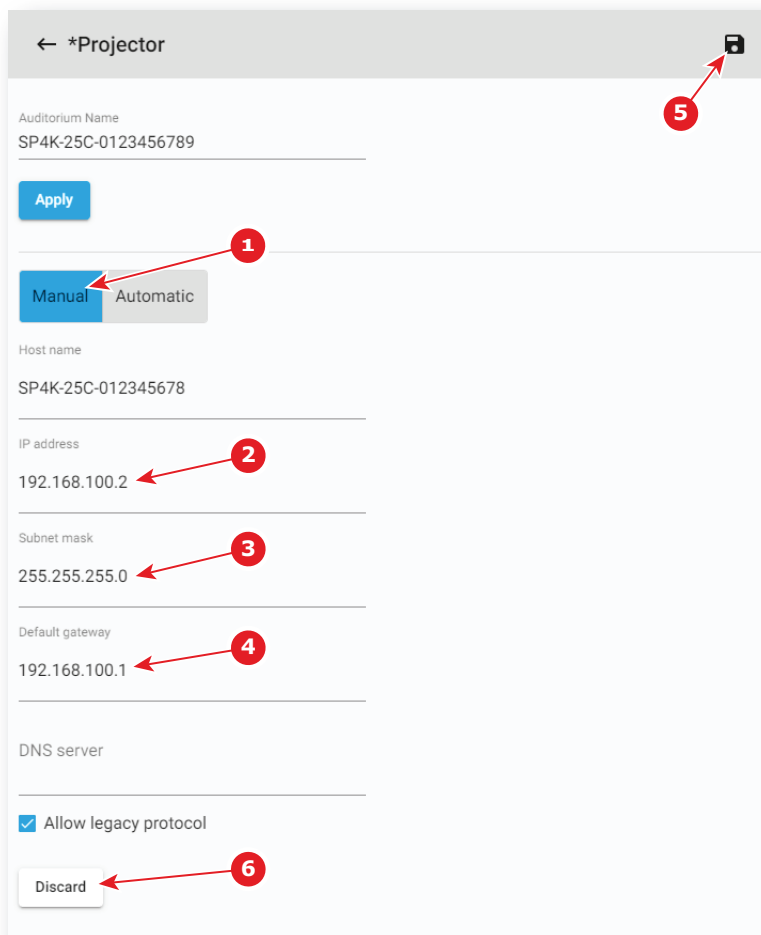



Image 14–6

2. Click **Manual** (reference 1).  
The network configuration parameters can now be edited.
3. Fill in the *IP address* (reference 2).  
 *Tip:* A network address contains 4 numbers with a value between 0 and 255, e.g. 192.168.1.101.
4. Fill in the *Subnet mask* (reference 3), e.g. 255.255.255.0.
5. Fill in the *Default Gateway* (reference 4), e.g. 192.168.1.1.
6. Click **Save** (reference 5) to activate.  
New settings are now active.  
or  
click **Discard** button (reference 8) to cancel all changes.



The address 0.0.0.0 can not be used in any of the fields.



To avoid an internal IP address conflict with the ICMP, the projector's IP address must be different from 192.168.254.x .

## 14.2 User management

### 14.2.1 About the user management menu

#### Location & access

Menu: Configuration > System access > Manage users

Level: Administrator

#### Overview

All users in the system are listed here. This panel can be used to add and delete users, as well as modifying their user rights.

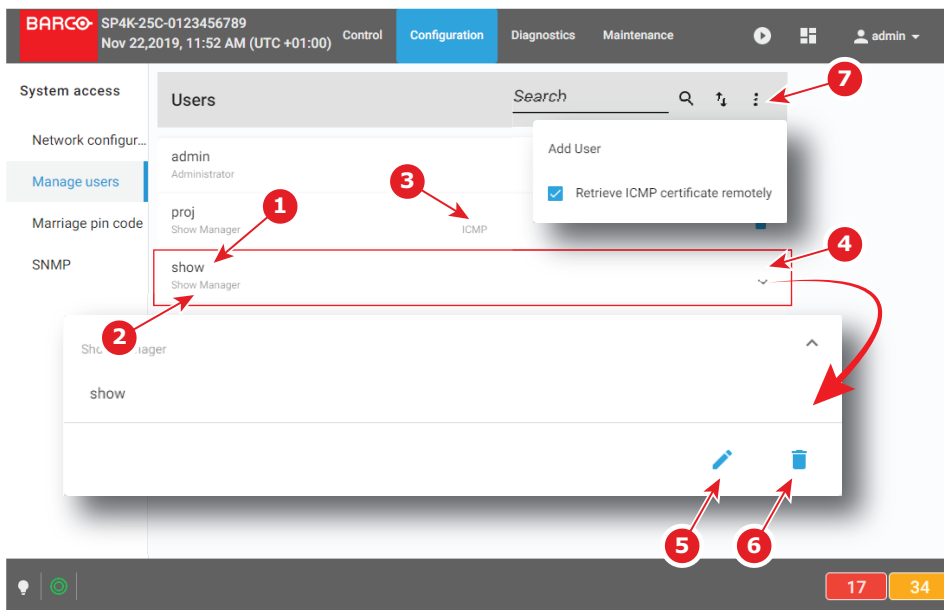

Image 14-7

Each user displayed in the user list has a name (reference 1). The group to which the user belongs is shown underneath the name (reference 2). If users are dedicated to the projector or a subsystem (e.g. ICMP) exclusively, this is indicated in the middle (reference 3).

Clicking on a user (reference 4) in the list allows to show it in its expanded form and displays a contextual menu.

Following actions are available in this menu:

- **Edit** (reference 5) allows to modify the user.
- **Delete** (reference 6) allows to remove the user from the list.

The menu (reference 7) allows to create a new user.

### 14.2.2 Menu access control editor

#### Overview

In Web Communicator, menus access are limited by operator level, see *User groups and limitations* table in “User rights”, page 60. But, for customized control level, additional limits can be added when creating or modifying users.

**List of additional limits available depending to operator level**

Top menu	Submenu	Administrator	Service Tech	Show Manager
Control	Projector	O	O	O
Configuration	Projector	O	O	N/A
	Color calibration	O	O	N/A
	Media server automation	O	O	N/A
	Media server	O	O	N/A
	Light output	O	O	N/A
	Projector automation	O	O	N/A
	License	O	N/A	N/A
	System access	O	O	N/A
Diagnostics	Monitoring	O	O	O
	Analysis	O	O	N/A
Maintenance	Software update	O	N/A	N/A
	Backup and restore	O	O	N/A
	Laser Bank	O	O	N/A
	Service mode	O	O	N/A
	RAID Storage	O	O	N/A

**How to add additional limits to user**

1. While in *Configuration > System access > Manage users*, during user creation or user modification and once user group is defined (reference 1), click on an element of the main menu, from example *Maintenance* (reference 2).

User name  
Admin2

Password  
.....

Use 8 or more characters

Confirm password  
.....

User group  
Administrator

**Access control**

Control  
1/1 selected

Configuration  
8/8 selected

Diagnostics  
2/2 selected

Maintenance  
5/5 selected

- Software update
- Backup and restore
- Laser Bank
- Service mode
- RAID Storage

Image 14–8

A list of submenu is displayed.

2. Check / uncheck boxes (reference 3) to add / remove access to submenus.
3. Repeat same operation on other items of the main menu, then when all parameters are correctly filled in, click **Save** icon to save modifications.

## 14.2.3 Creating a user

### Location & access

Menu: Configuration > System access > Manage users

Level: Administrator

### How to add a user

1. While in *Configuration > System access > Manage users*, click on the menu (reference 1) > **Add User** (reference 2).

An *Add new user* menu is displayed (reference 3).

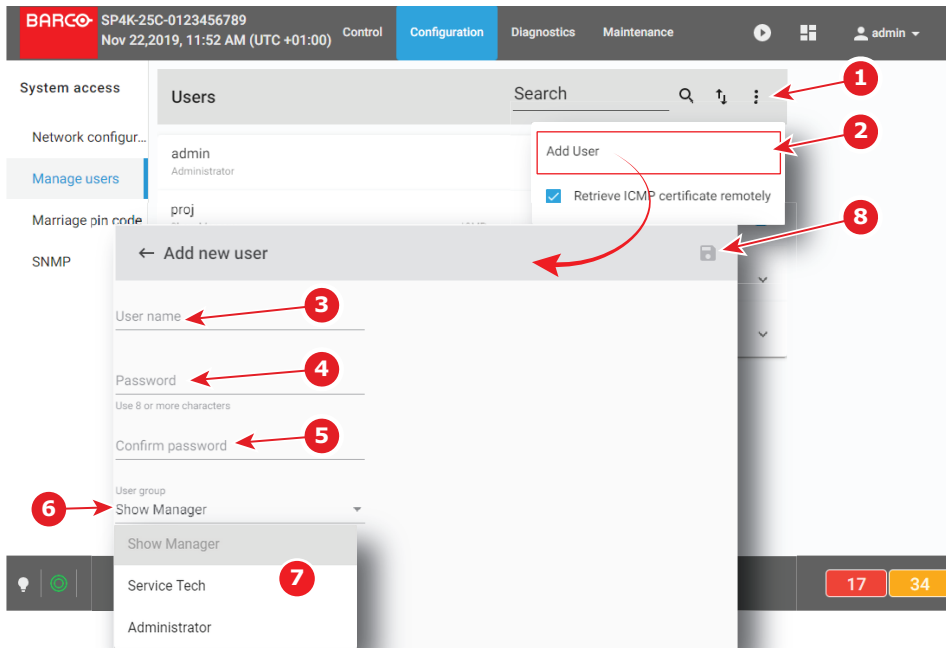



Image 14–9

2. Fill in an appropriate *User name* (reference 3).
3. Fill in a strong new password (reference 4) and repeat the password in the Confirm password field (reference 5) to ensure there were no errors made the first time around.
  -  *Tip:* Use 8 or more characters.
4. Click on the *User group* field (reference 6) to display the list of available user groups (reference 7), and select the desired user group.
5. If necessary add additional user limits (menu access restriction). See [“Menu access control editor”, page 285](#).
6. When all parameters are correctly filled in, click the **Save** icon (reference 8) to save this new user.

## 14.2.4 Modifying settings of a user

### Location & access

Menu: Configuration > System access > Manage users

Level: Administrator

### How to edit user settings

1. While in *Configuration > System access > Manage users*, find and click on the desired user. The user is displayed in its expanded form with menu.



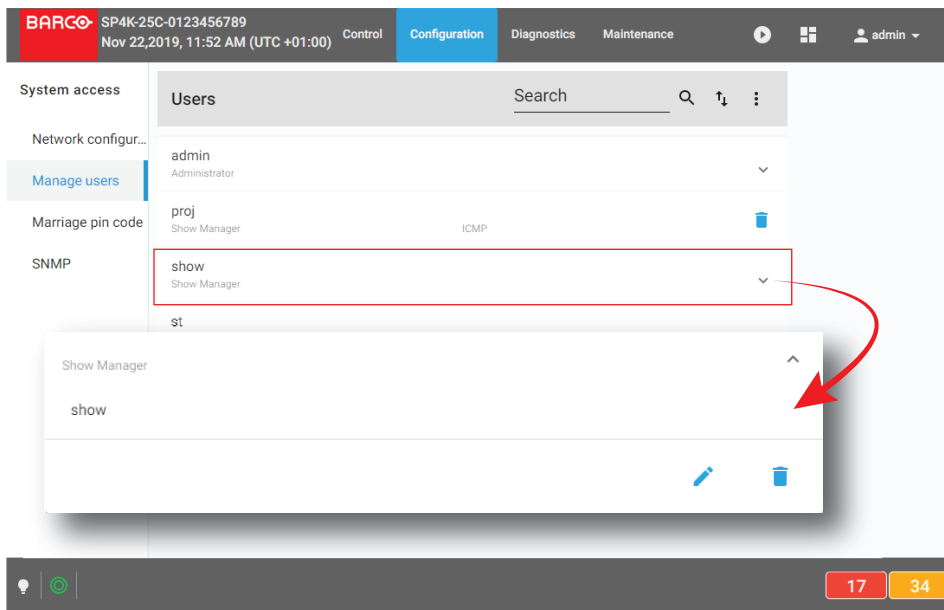



Image 14–10

- Click the **Edit** icon.  The *Edit User* page is displayed.

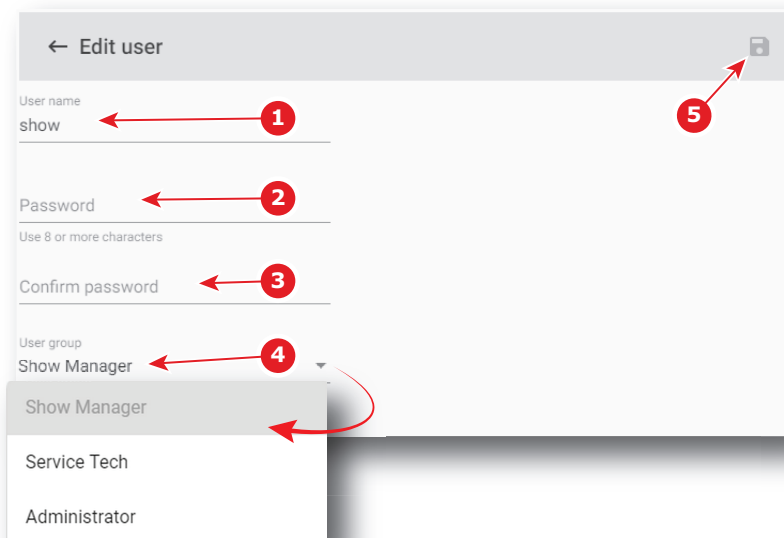

Image 14–11

- Enter or change the user name (reference 1).  
or  
click in *user group* field (reference 5) to display the list of user groups available (reference 6), then select a user group to promote or demote the user.
- Fill in a strong new password (reference 2) and repeat the password in the Confirm password field (reference 3) to ensure there were no errors made the first time around.
- Click on the *User group* field (reference 4) to display the list of available user groups, and select the desired user group.
- If necessary add additional user limits (menu access restriction). See [“Menu access control editor”](#), page 285.

- When all parameters are correctly filled in, click the **Save** icon (reference 5) to save this user.

## 14.2.5 Deleting a user

### Location & access

Menu: Configuration > System access > Manage users

Level: Administrator

### How to delete a user

- While in *Configuration > System access > Manage users*, find and click on the user you want to remove. The user is displayed in its expanded form with menu.

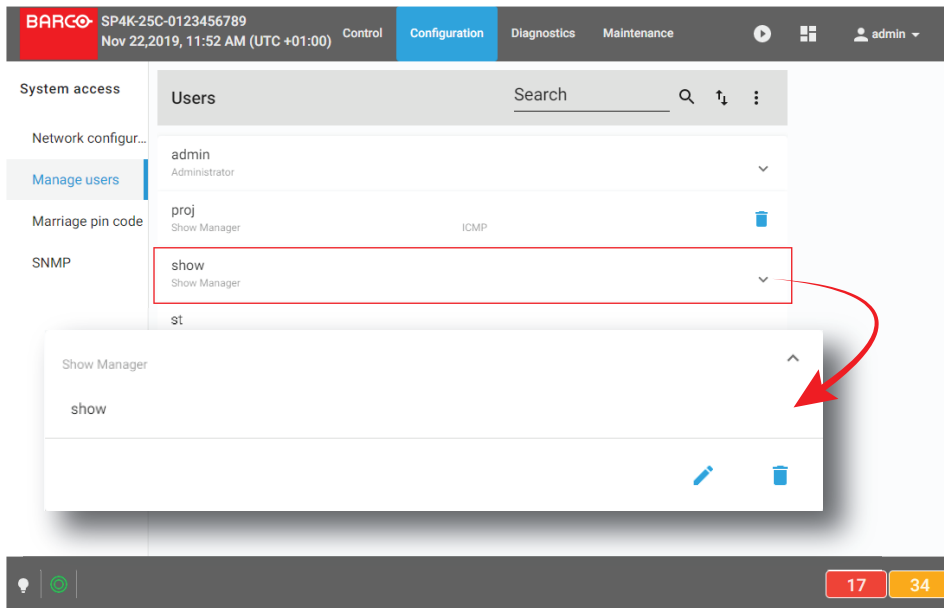

Image 14-12

- Click the **Delete** icon in the menu and confirm with **OK**. 

## 14.3 Marriage pin code

### 14.3.1 About marriage PIN code

#### Location & access

Menu: Configuration > System access > Marriage pin code

Level: Administrator, Service technician

#### Overview

All marriage PIN codes available in the system are listed here. User need use this menu to create, remove, modify PIN code.

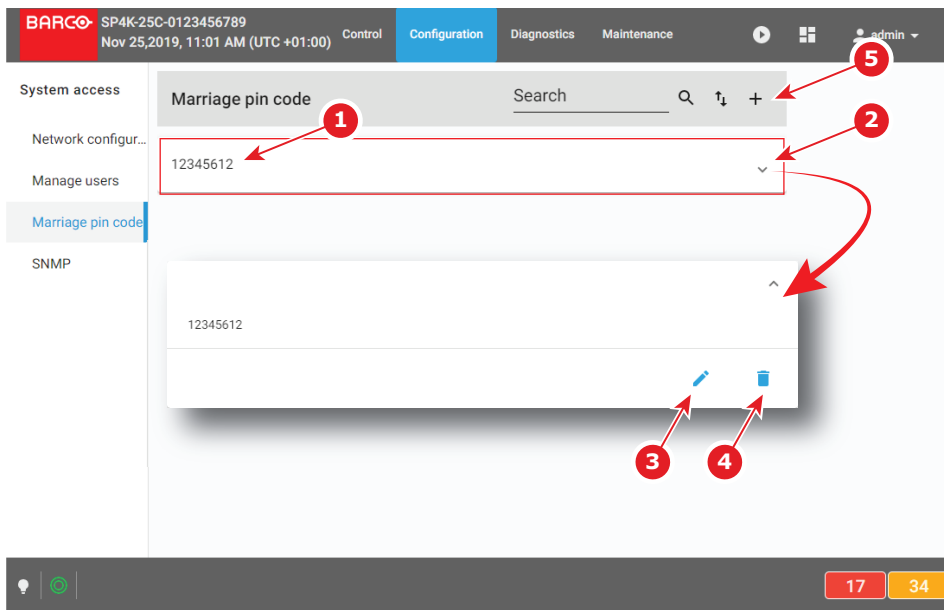

Image 14–13

A marriage PIN code is identified by a number of up to 8 digits (reference 1).

Clicking on a marriage PIN code (reference 2) in the list allows to show it in its expanded form and displays a contextual menu.

Following actions are available in this menu:

- **Edit** (reference 3) allows to modify the PIN code.
- **Delete** (reference 4) allows to remove the PIN code from the list.

**New** (reference 5) allows to create a new marriage PIN code.

## About Marriage

For security reasons, projector and mediablock (ICMP-X or ICP-D) are linked together via an anti-tampering system. Physically replacing mediablock will introduce marriage tamper between the projector and mediablock. This is the reason why the technician who inserted a new mediablock must finalize the installation procedure by entering a marriage PIN code (see installation manual for more details concerning the entry of PIN code via touch display located on *Input & Communication* side of the projector).

Entering a pin code is a registered operation. So for traceability reasons, it is recommended to create a PIN code for each user supposed to perform a marriage operation.

PIN code must contain up to 8 digits. These digits can be any combination of the digits 1 to 9. *12345612* is provided as default PIN code.

### 14.3.2 Creating a new marriage PIN code

#### Location & access

Menu: Configuration > System access > Marriage pin code

Level: Administrator, Service technician

#### How to create a new PIN code

1. While in *Configuration > System access > Marriage pin code*, click on **New** (reference 1) located on the top right of the list.

A new untitled PIN code (reference 3) is displayed in PIN code editor (reference 2).

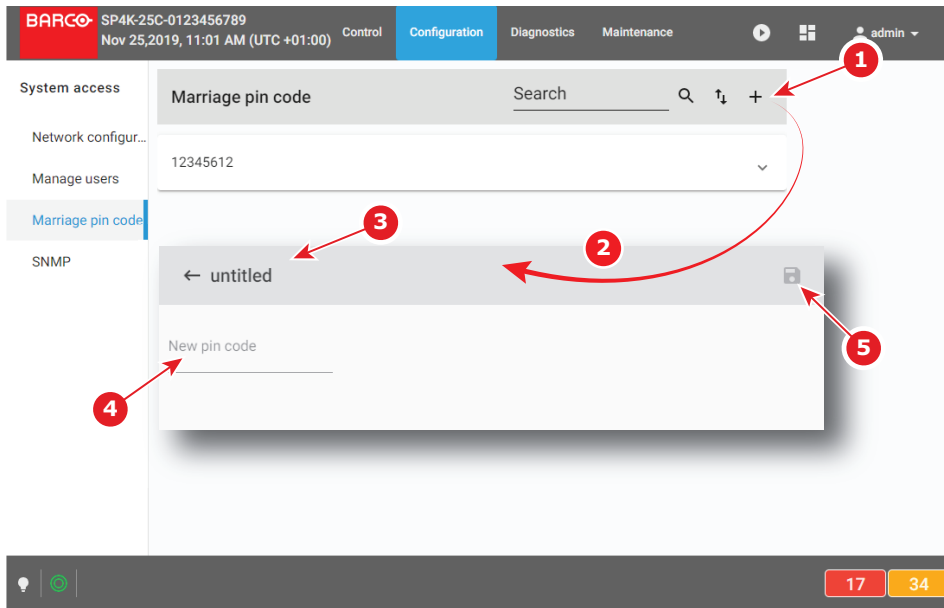

Image 14-14

2. Click in the *New PIN code* field (reference 4), then enter the new PIN code. **Save** (reference 5) is now accessible.
3. Click **Save** (reference 5) to validate the new code.  
New PIN code is now valid (it will be accessible to the list of PIN codes).

### 14.3.3 Deleting a marriage PIN code

#### Location & access

Menu: Configuration > System access > Marriage pin code

Level: Administrator, Service technician

#### How to delete

1. While in *Configuration > System access > Marriage pin code*, find and click on the PIN code you want to delete.  
The PIN code is displayed in its expanded form with menu.

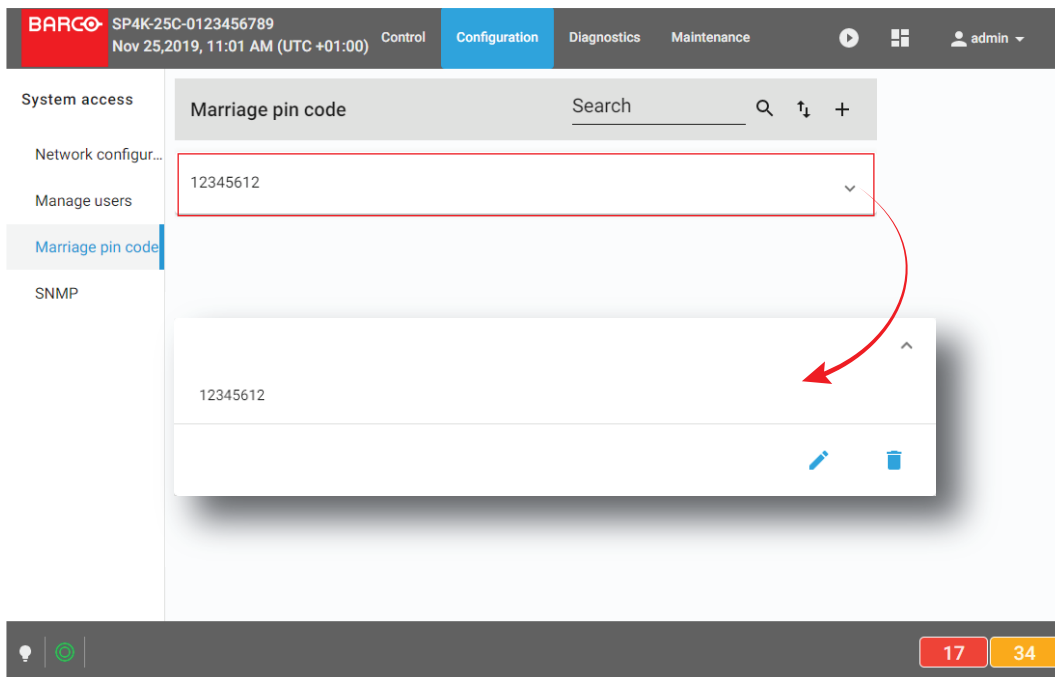

Image 14–15

2. Click the **Delete** icon and confirm.



PIN code is removed from the list.

### 14.3.4 Modifying a marriage PIN code

#### Location & access

Menu: Configuration > System access> Marriage pin code

Level: Administrator, Service technician

#### How to modify

1. While in *Configuration > System access > Marriage pin code*, find and click on the PIN code you want to modify.

The PIN code is displayed in its expanded form with menu.

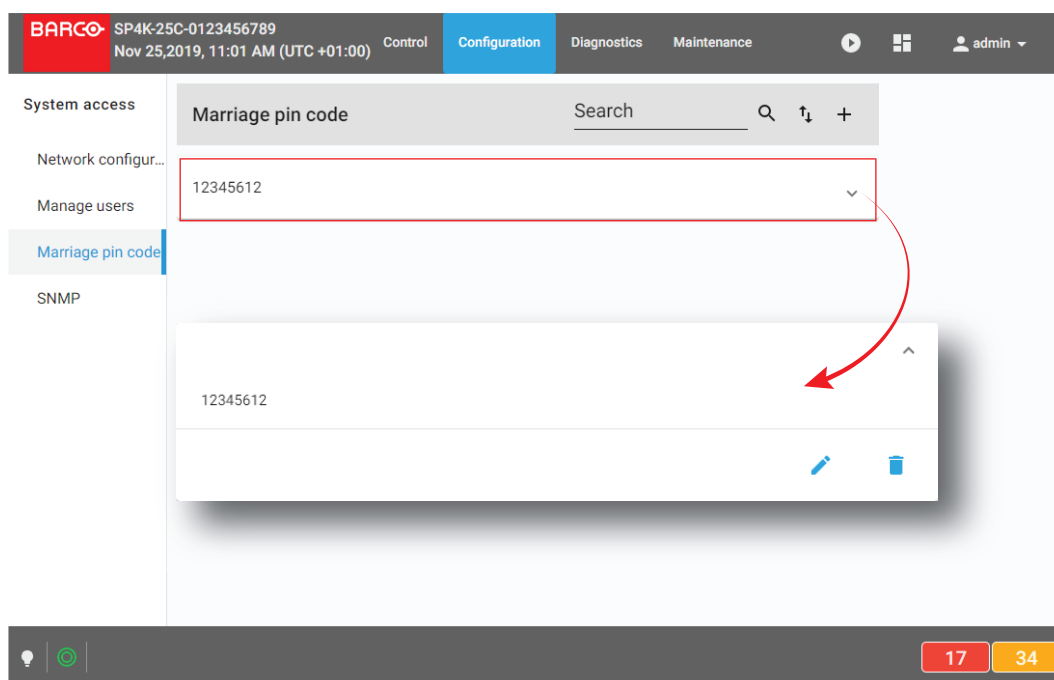

Image 14–16

2. Click the **Edit** icon.    
 *PIN code editor* page is displayed.

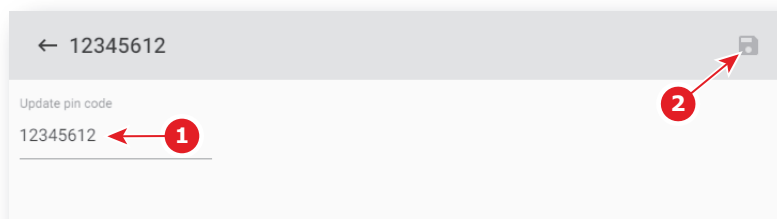

Image 14–17

3. Enter a new PIN code (reference 1). Use a numeric value of 1–8 digits.
4. Click the **Save** icon (reference 2) to validate the new code.   
 The new PIN code is now valid (it will be accessible to the list of Pin codes).

## 14.4 SNMP

### 14.4.1 About SNMP configuration

#### Location & access

Menu: Configuration > System access > SNMP

Level: Administrator, Service technician

#### Overview

This panel allows to configure the Simple Network Management Protocol (SNMP), the Internet standard protocol for collecting and organizing information about managed devices on IP networks.

Set time between two traps to be sent to the management servers. This time is set in minutes and can be different for *Non critical trap* (reference 1) and *Critical traps* (reference 2).

Each trap receivers is designed by its IP address (reference 3) in the *Trap Destinations* list.

Clicking on a trap receiver (reference 5) allows to show it in its expanded form (reference 6) and displays a contextual menu.

Following actions are available in this menu:

- **Edit** (reference 7) allows to modify the IP address of the receiver.
- **Delete** (reference 8) allows to remove the receiver from the list.

**Add** (reference 4) allows to add a new receiver.

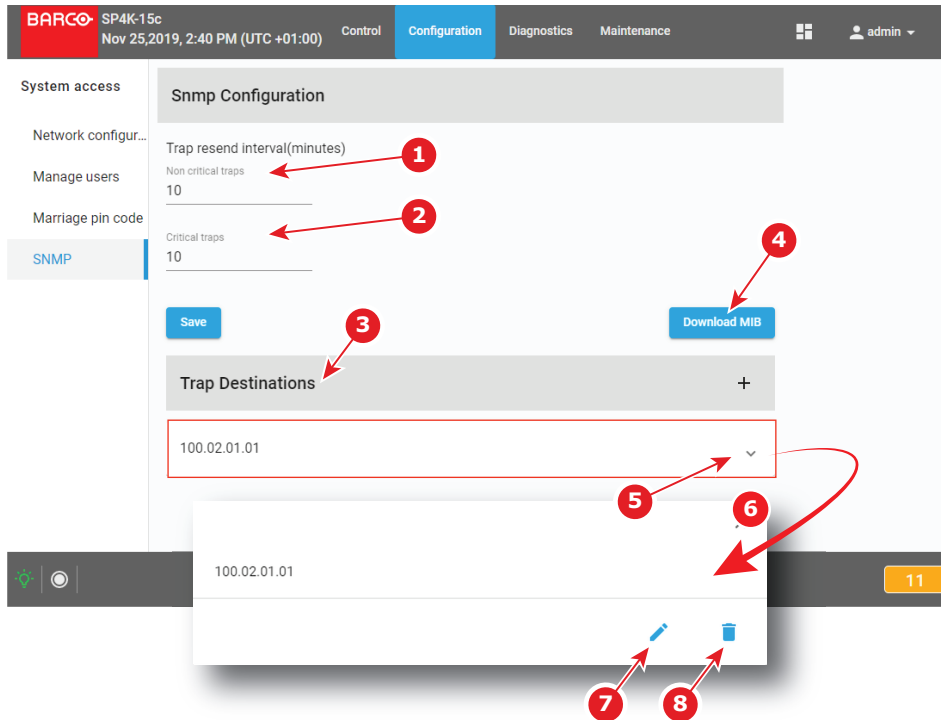

Image 14–18

## 14.4.2 Modifying the trap resend interval

### Location & access

Menu: Configuration > System access > SNMP

Level: Administrator, Service technician

### How to modify the trap resend interval

1. While in *Configuration > System access > SNMP*, click in *Non critical traps* field (reference 1), then enter the time that the projector needs wait between two sends of non critical traps to the management server.
2. Click in *Critical traps* field (reference 2), then enter the time that the projector needs wait between two sends of critical traps to the management server.

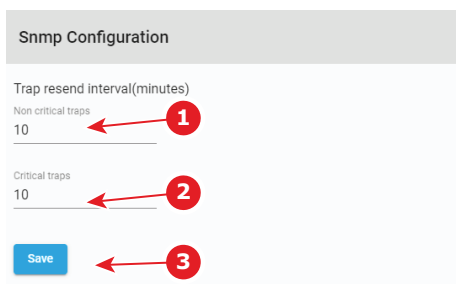

Image 14–19

3. Click **Save** (reference 3) to apply changes.

### 14.4.3 Adding a new SNMP receiver

#### Location & access

Menu: Configuration > System access > SNMP

Level: Administrator, Service technician

#### How to add new receiver

1. While in *Configuration > System access > SNMP*, click **Add** (reference 1).  
A window prompting you to enter an IP address is displayed (reference 2).

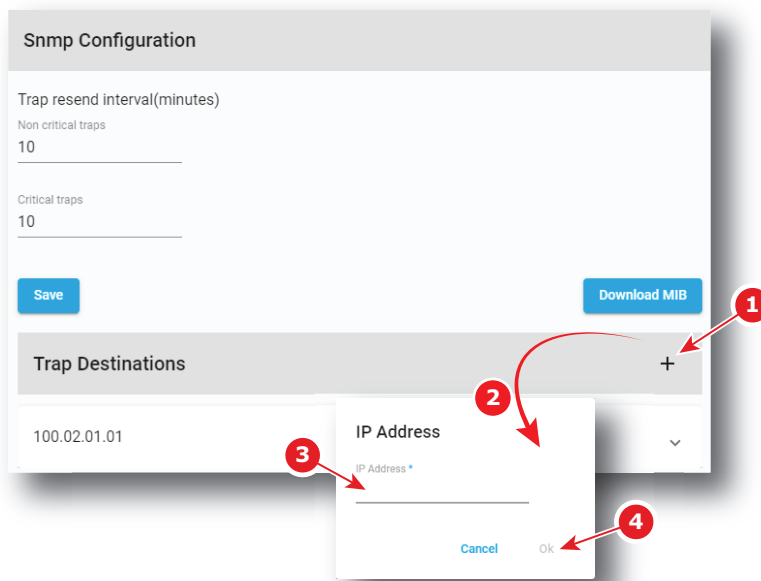

Image 14–20

2. Enter the IP address of the receiver (reference 3), then click **OK** (reference 4).  
New receiver is now displayed in the *Trap Destinations* list.

### 14.4.4 Deleting a SNMP receiver

#### Location & access

Menu: Configuration > System access > SNMP

Level: Administrator, Service technician

#### How to delete a receiver

1. While in *Configuration > System access > SNMP*, click on the undesired receiver (reference 1) in the *Trap Destinations* list.  
The receiver is displayed in its expanded form with menu (reference 2).



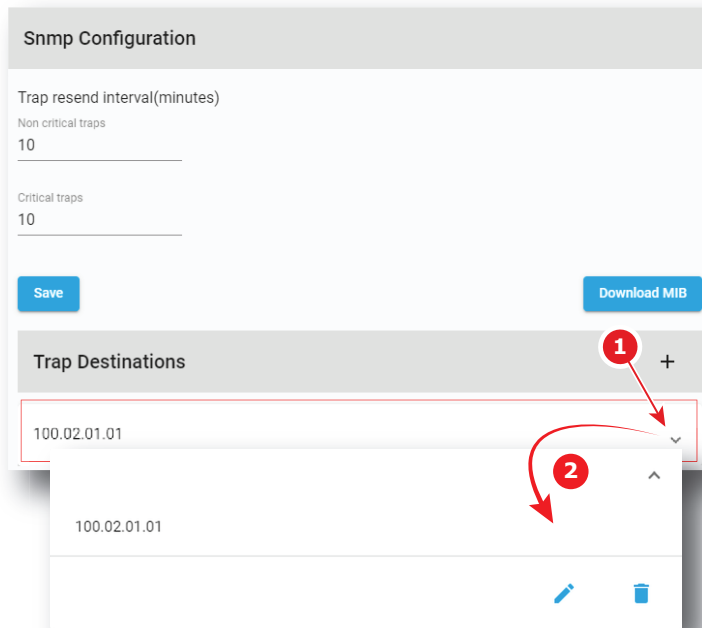



Image 14–21

2. Click the **Delete** icon in the menu and confirm. 

The receiver is removed from the *Trap Destinations* list.

## 14.4.5 Modifying the IP of a SNMP receiver

### Location & access

Menu: Configuration > System access > SNMP

Level: Administrator, Service technician

### How to modify the IP of a SNMP receiver

1. While in *Configuration > System access > SNMP*, click on the desired receiver (reference 1) in the *Trap Destinations* list.

The receiver is displayed in its expanded form (reference 2).

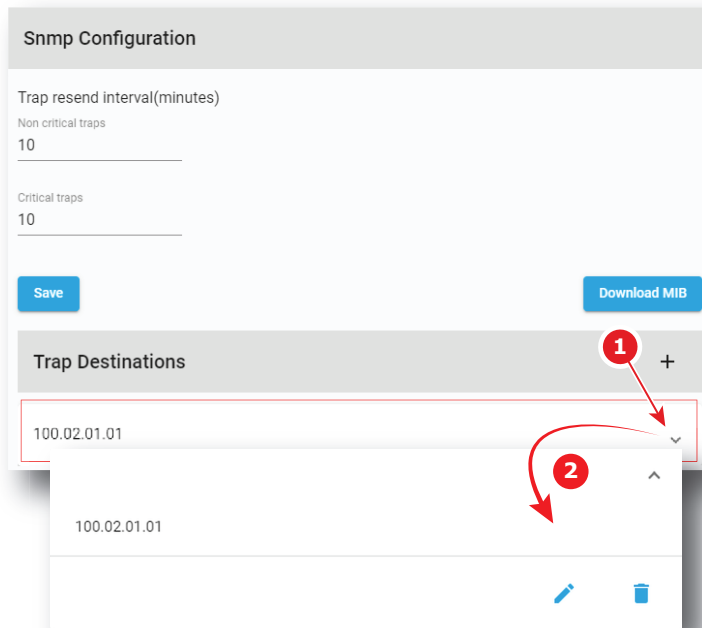

Image 14–22

2. Click the **Edit** icon. 

A window with the current IP address of the receiver is displayed.

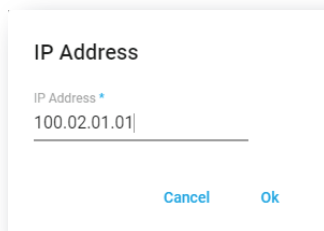

Image 14–23

3. Enter the new IP address of the receiver and confirm with **OK**.  
The receiver with its new IP address is displayed in the *Trap Destinations* list.

## 14.5 Multi projectors

### 14.5.1 About Multi projectors

#### Location & access

Menu: Configuration > System access > Multi projectors

Level: Administrator, Service technician

#### Overview

This panel allows to manage slave and master projectors in multi projectors configuration. A multi projector setup is used in e.g. a 3D setup where the first projector projects the left image and the second projector the right image.

One projector must be designed as master and the others as slaves. The *Multi projectors* list is created on the master (all slave projectors must be known by the master).

There are several tabs in the Multi projectors panel that corresponding to several kinds of multi projector configurations:

- **Linked ICMP**, used by example in 3D setup where the first projector projects the left image and the second projector the right image.
- **Linked CLO**, used when it necessary that several projectors are using the same light output.

The use of several multi projector configurations in same time is possible.

## Linked ICMP

This tab is available when ICMP is present in the projector.

A chain of 50 Ohm coaxial cables (equipped with BNC connectors) is used to connect the sync signal between each projector. The number of slaves is theoretically not limited.

In the *Multi projectors* list, each slave projector is designed by its IP address (reference 1) or by its Host name. Both master and slave projectors need to be on the same projector control network.

*Player Frames* parameter (reference 2) indicates if the slave plays the right or the left image, or the both in same time.

*BNC mode* parameter indicates the protocol used by the slave for the BNC cable sync (this link allows a correct synchronisation between the master and the slave). The following protocols can be used:

- Sync: default sync signal (used value if the slave is not the last one in the chain of multi projectors).
- Ltc: Linear time code (usually used for the last slave in a multi projectors configuration).

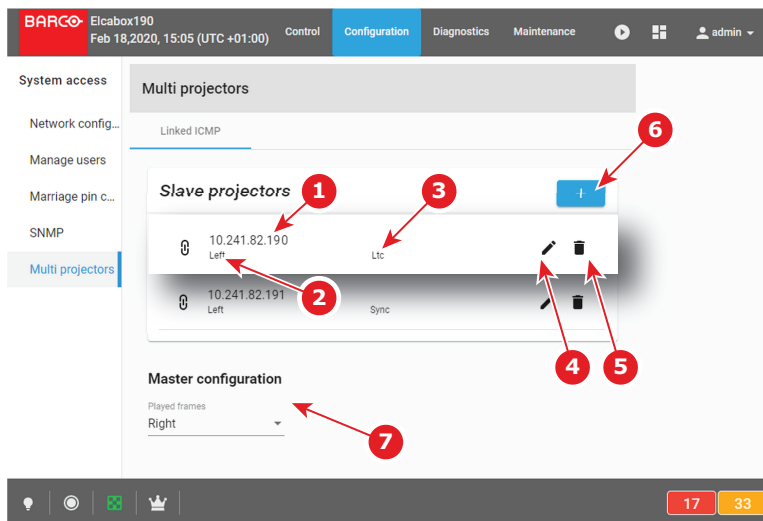

Image 14–24

Using the **Edit** icon (reference 4), you can display the *Edit* window of the concerned slave projector and modify its settings (Ip address, played frames, BNC mode).

Using the **plus** button (reference 6), you can add new slave projector. You can remove a slave projector using the **trash bin** icon (reference 5).

The only available parameter for the Master projector configuration is the *Player Frames* parameter (reference 7) that allows to choose if the master plays the right or the left image, or the both in same time.

## Linked CLO

This multi projector mode use the local network. It is based on IP addresses of projectors. No additional link is needed between the projectors.

When 2 projectors are projecting on the same screen, e.g. for projecting 3D images, then it necessary that both projectors are using the same light output, otherwise a difference in brightness will be visible between both images.

To obtain this goal, one projector will be set as master and this master will manipulate the target CLO value of the slave so that the lamp output will be aligned between both projectors. When the lamp output of the master changes, then the lamp output of the slave will follow.

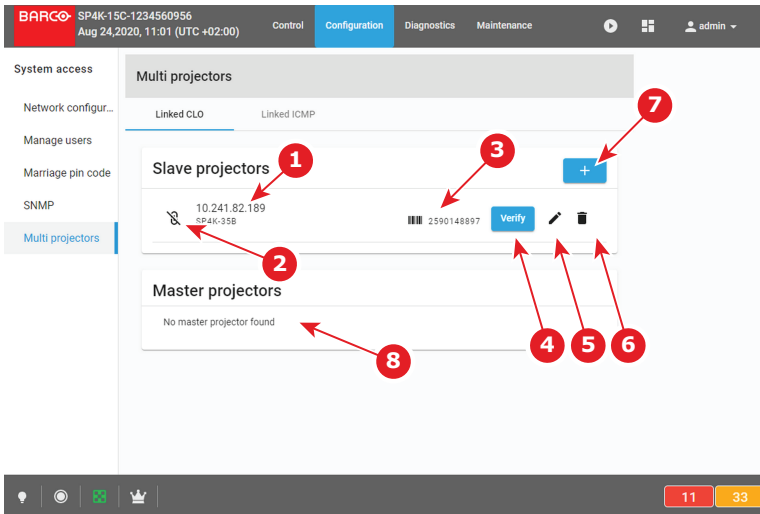

Image 14–25

In the *Slave projectors* list, each slave projector is designed by its IP address (reference 1). Both master and slave projectors need to be on the same projector control network.

Icon (reference 2) symbolizing the connection with the slave remains crossed out until the link between the master and the slave has been confirmed by using **verify** the button (reference 4).

To identify easily the slave projector, a bar code and the serial number of the targeted machine is displayed (reference 3).

Using Directly the **plus** button (reference 7) to add new slave projector (*Add projector as slave* window is dispiled). You can remove a slave projector using the **trash bin** icon (reference 6).

Using the **Edit** icon (reference 5), you can also display the *Add projector as slave* window to directly replace current projector by another one in the list.

In the *Master projectors* list (reference 8), a list of master projectors already defined in the network is displayed.

## 14.5.2 Linked ICMP (Adding, modifying and deleting a slave projector)

### Location & access

Menu: Configuration > System access > Multi projectors

Level: Administrator, Service technician

### How to add slave

1. While in tab *linked ICMP* in *Configuration > System access > Multi projectors*, click on **Add** (reference 1). A window prompting you to enter IP address of the slave projector is displayed (reference 2).

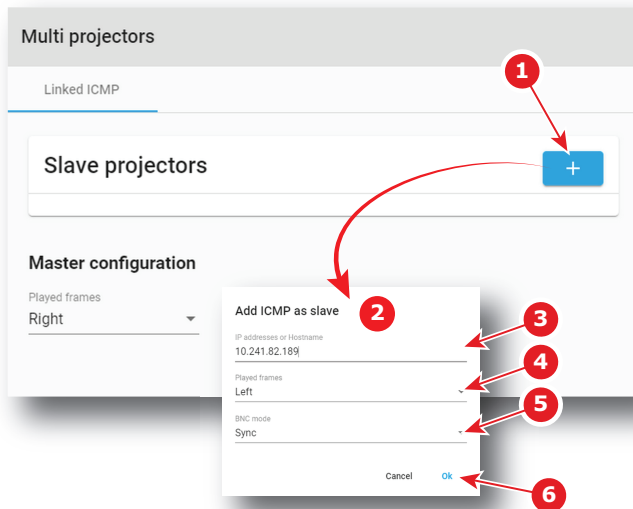

Image 14–26

2. Enter the IP address (or Host name) of slave projector (reference 3),  
or  
Select an IP address in the list automatically proposed (List of available projectors in the local network).
3. Select in the *played frames* drop down (reference 4) which image the slave will play: the right or the left image, or the both in same time.
4. Select a protocol of synchronisation for the BNC cable (the link that allows synchronisation between the master and the slave) by clicking on the drop down list (reference 5).
5. Click **Ok** (reference 6) .  
New slave projector is now displayed in the *Slave Projectors* list.

### How to modify settings of a slave projector

1. While in tab *linked ICMP* in *Configuration > System access > Multi projectors*, click on **Edit** icon (reference 1) of the projector slave you want to remove.  
Edit window of the slave projector is displayed (reference 2).

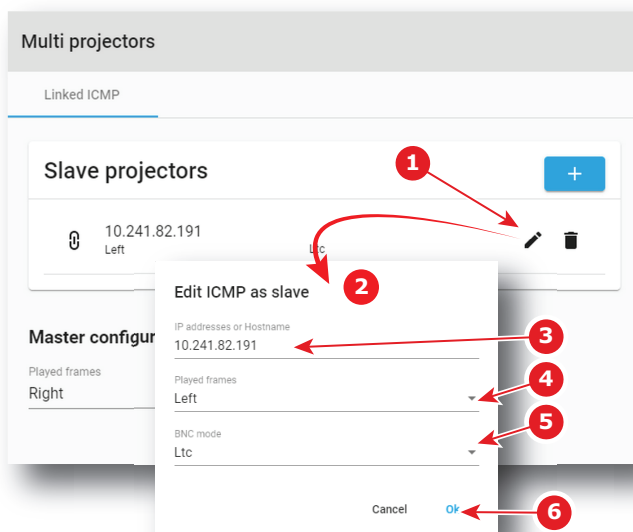



Image 14–27

2. Edit the desired values (reference 3 to 5),

 **Note:** Please refer to section “[Linked ICMP \(Adding, modifying and deleting a slave projector\)](#)”, page 300 to correctly modify slave projector parameters.

3. Confirm modifications with **OK** (reference 6).

Slave projector is displayed in the *Slave Projectors* list with its new settings.

## How to delete slave projector

1. While in tab *linked ICMP* in *Configuration > System access > Multi projectors*, click on **Delete** icon (reference 1) of the projector slave you want to remove.

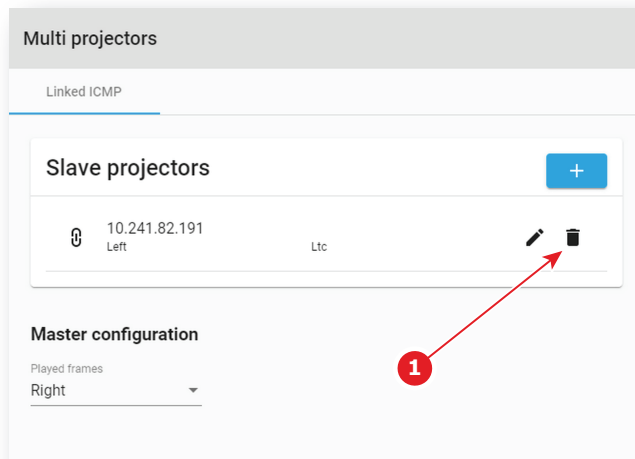

Image 14–28

Projector is removed from the *Slave Projectors* list without confirmation.

## 14.5.3 Linked CLO (Adding, modifying, verifying and deleting a slave projector)

### Location & access

Menu: Configuration > System access > Multi projectors

Level: Administrator, Service technician



**To obtain an efficient linked CLO behaviour, the CLO sensor of each units of the group (master and slaves) need to be correctly calibrated. Please refer to Configuration > Light output > Sensor section.**

### How to add slave

1. While in tab *linked CLO* in *Configuration > System access > Multi projectors*, click on **Add** (reference 1).  
A window *Add projector as slave* is displayed.

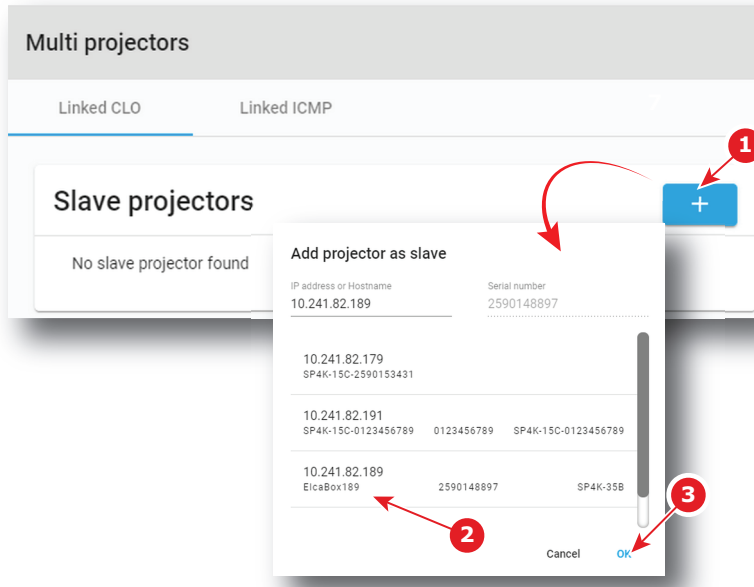

Image 14–29

2. Select an IP address (reference 2) in the list automatically proposed (List of available projectors in the local network).
3. Click **Ok** (reference 3) .

New slave projector is now displayed in the *Slave Projectors* list.

### How to verify secure connection with the slave projector

1. While in tab *linked CLO* in *Configuration > System access > Multi projectors*, click on **Verify** icon (reference 1) of the projector slave you want to verify.

The window *Secure connection* is displayed.

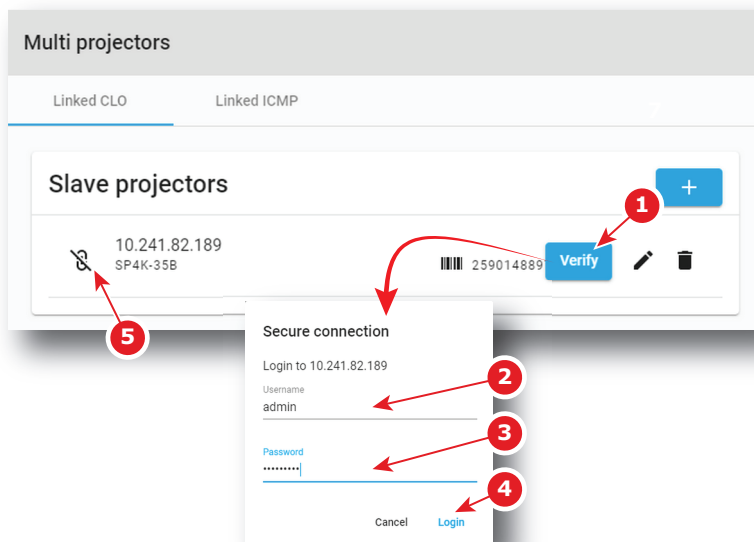

Image 14–30

2. Sign in using user name (reference 2) and password (reference 3) then click login (reference 3).  
Secure connection is checked.
3. If connection is successfully verified a confirmation message is displayed. Click **Ok**.

The connection with the slave is secularized now: Icon (reference 5) symbolizing the connection with the slave is uncrossed.

or

if connection failed an error message is displayed. Click **Ok** then verify credentials and check projectors certificates and their validity dates.

## How to modify settings of a slave projector

1. While in tab *linked CLO* in *Configuration > System access > Multi projectors*, click on **Edit** icon (reference 1) of the projector slave you want to exchange.

The window *Add projector as slave* is displayed.

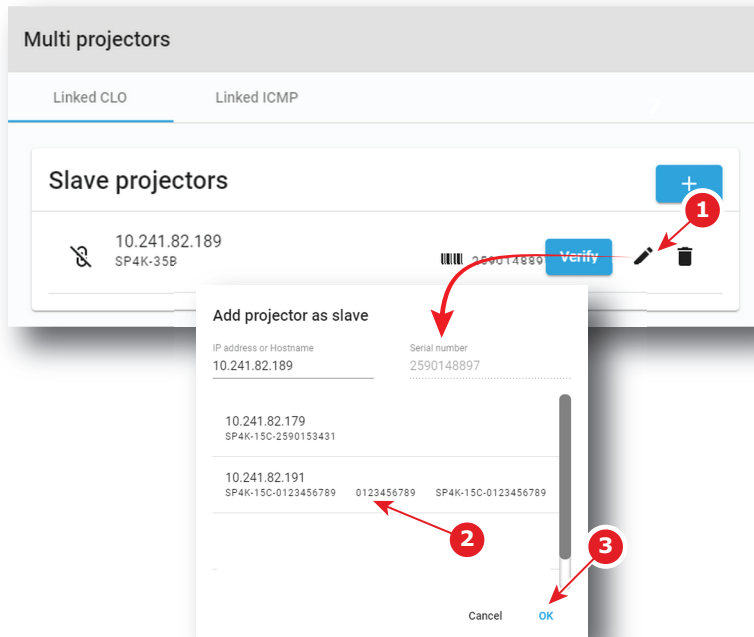

Image 14–31

Note that the address of the projector currently edited is not displayed in the list of available projectors.

2. Select an IP address (reference 2) in the list automatically proposed (List of available projectors in the local network without the current selected ).
3. Click **Ok** (reference 3) .

The previous projector is removed and the new slave projector is now displayed in the *Slave Projectors* list.

## How to delete slave projector

1. While in tab *linked CLO* in *Configuration > System access > Multi projectors*, click on **Delete** icon (reference 1) of the projector slave you want to remove.



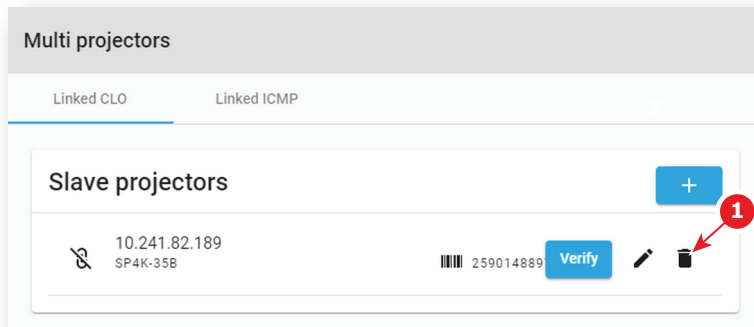

Image 14-32

**2. Confirm with OK**

Projector is removed from the *Slave Projectors* list.



# Diagnostics - Monitoring

# 15

15.1	System information .....	308
15.2	RAID information .....	309
15.3	Notifications .....	309
15.4	Metrics .....	312

## About Monitoring

The Monitoring menu is used to retrieve system information and notifications.

## 15.1 System information

### Location & access

Menu: Diagnostics > Monitoring > System information

Level: Administrator, Service technician, Show manager

### Overview

This panel provides information concerning the product (projector + Cinema processor), settings and network configuration.



This panel is read only. To modify Network parameters displayed here, please use [“Network configuration”, page 278.](#)

The screenshot shows the BARCO SP4K-25C diagnostics interface. The top navigation bar includes 'Control', 'Configuration', 'Diagnostics' (selected), and 'Maintenance'. The user is logged in as 'admin'. The interface is divided into three main sections:

- Monitoring:** A sidebar menu with options for 'System information' (selected), 'RAID information', 'Notifications', and 'Metrics'.
- Product information:**
  - Model: SP4K-25C
  - Article number: R9008862
  - Lens: FUJINON(R) 0.98" DC2K 1...
  - Firmware version: 1.5.0rc-n891
  - Projector serial number: 2590178148
  - ICMP serial number: 9730738680
- Network information:**
  - Hostname: 101
  - IP address: 10.241.82.101
  - Subnet: 255.255.254.0
  - Default gateway: 10.241.82.1
  - Configuration: AUTO
- Settings:**
  - Macro: Not selected
  - White point target: Native (LSC, 14fL)
  - Light output mode: Normal (Power, 20%)
  - Input: Icmp\_MediaPlayer (PCF, DCDM\_XYZ\_auto)
  - Picture: FullScreen (3D, No3D)
  - TCGD 3D left eye: DC28\_DCL\_XYZE\_314\_351 (TCGD 2D/3D right eye: DCDM\_XYZ\_auto.PCF)
  - MCGD 3D left eye: MeasuredColors3D\_Left (MCGD 2D/3D right eye: MeasuredColors)
  - LUT-SCC: Manual override (Test patterns: Not selected)

Image 15-1

### Product information

- **Model** : Indicates the Model of the projector (e.g. DP4K-xx).
- **Article number**: Indicates article number of the projector (e.g. R90xxxxx).
- **Projector serial number**: Indicates the serial number of the projector.
- **ICMP/ICP serial number**: Indicates the serial number of the ICMP (Integrated Cinema Media Processor) or ICP (Integrated Cinema Processor) present in the projector.
- **Firmware version**: Indicates the software package version installed on the device.
- **Lens**: Indicates the lens installed on the device.

### Network information

- **Host name**: Contains the host name assigned to the projector to identify it in the theater network (e.g. projector1).
- **IP address**: Contains the IP address of the projector required for network communication (e.g. 10.98.0.245).
- **Subnet**: The subnet mask is the number that is used to identify a subnet so that IP addresses can be shared on a local area network (e.g. 255.255.254.0).
- **Default gateway**: Contains the default gateway IP address of the projector (router) required for network communication (e.g. 10.98.0.1).
- **Configuration**: MANUAL or AUTO. Indicates if the IP address has been assigned manually by user or automatically by DHCP (Dynamic Host Configuration Protocol) server.

## Settings

This section provides an overview of the settings currently applied on the projector.

## 15.2 RAID information

### Location & access

Menu: Diagnostics > Monitoring > RAID information

Level: Administrator, Service technician, Show manager

### Status overview

While in *Diagnostics > Monitoring > RAID information*, the RAID status is given.

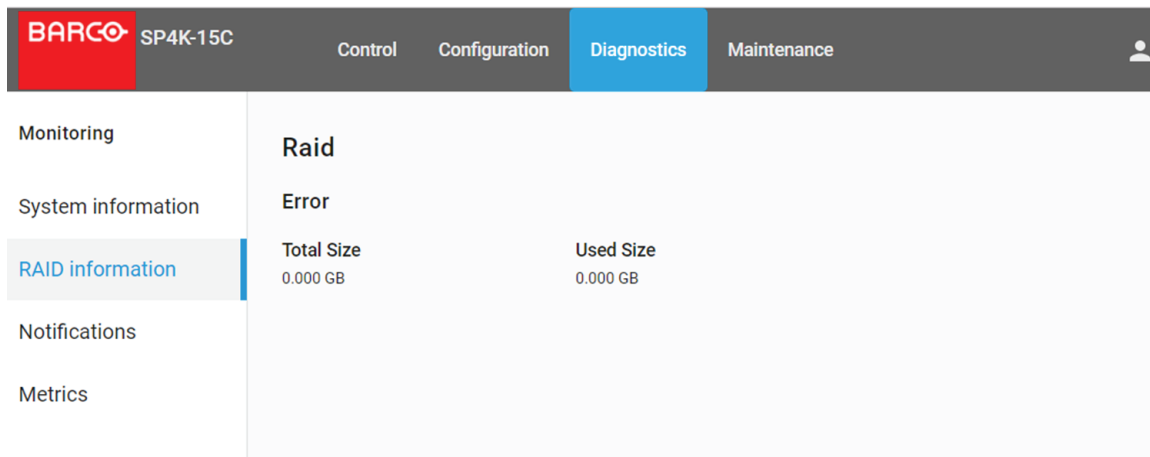

Image 15–2

The following information is given:

- Storage status
  - Storage state
  - Errors
  - Used size in GB
  - Total storage size in GB.

## 15.3 Notifications

### Location & access

Menu: Diagnostics > Monitoring > Notifications

Level: Administrator, Service technician, Show manager

### Overview

The complete list of errors, warning and maintenance messages is displayed in this menu. Operational notifications and hardware errors encountered on the projector and the Cinema Processor (ICP or ICMP) are grouped in the same list.



Hardware errors reported here are generally resolved by a technical intervention. Operational errors are easier to solve and generally requires just an operator intervention. This last category of error is more common and is often due to problems with invalid content.

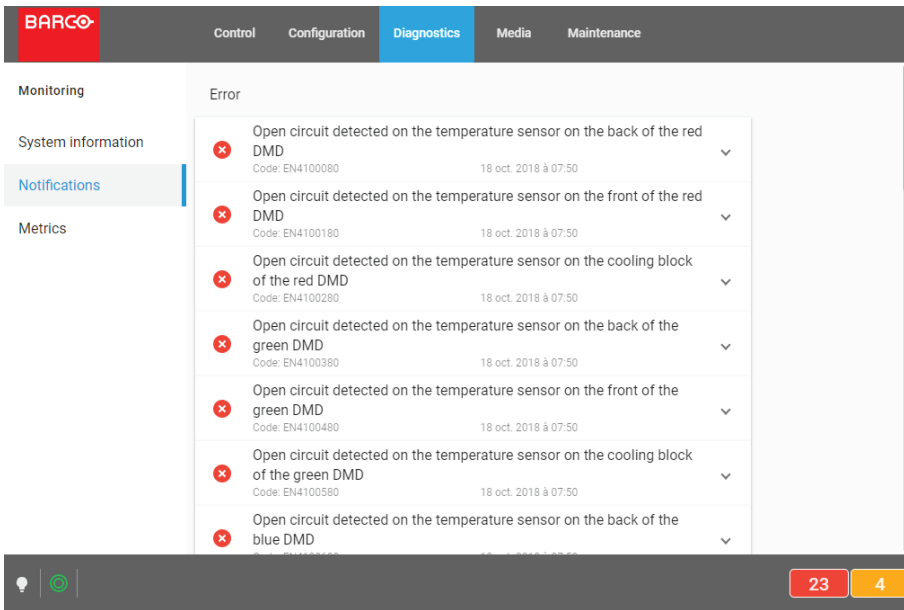

Image 15-3 Diagnostics > Monitoring > Notifications

## Messages filtering

Some tabs on the top of the list allow you to filter messages:

- **Active:** click on this tab allows to display all message still actives (not solved). Error messages are displayed first in this list, followed by warnings and finally you will find eventual info messages not already automatically solved.
- **Since boot:** click on this tab allow to display all messages activated since last projector start. Messages are filtered by creation dates (most recent message in on the top of the list).
- **History:** this tab allows to load and display list of all maintenance messages raised on the projector. Messages are filtered by creation dates (most recent message in on the top of the list). To save system resources, this list is not automatically displayed. It is necessary to activate the message display by pressing **Load** button.

## Notification description

Notifications are given with an identifier (code error number), a date and a description. An icon indicates the error level.

There are three error levels:

- **Error:**  
Icon composed with a white cross on a red circle indicates an “Error”. This error must be resolved as soon as possible to prevent damage to the projector and perform the show.



Image 15-4 Error

- **Warning:**  
Icon composed with a white exclamation mark on a yellow triangle indicates a “Warning”. This warning must be resolved as soon as possible to prevent future issues with the projector and allows providing a complete performance during the show. An unresolved Warning can quickly escalate and become an error.



Image 15-5 Warning

- **Info:**  
Icon composed with a white exclamation mark on a blue circle indicates an “Information” message. This type of message are used to signal a modification of the projector status or to indicate that maintenance action is needed.



Image 15-6 Info

## Diagnostic Companion

Multiple situations and solutions are possible for one error (or warning). If they are available, situations and possible solutions are presented in the extended version of the notification in table form.

### How to display

1. While in *Diagnostics > Monitoring > Notifications*, click on the notification.

The notification is displayed in its expanded form with explanations.

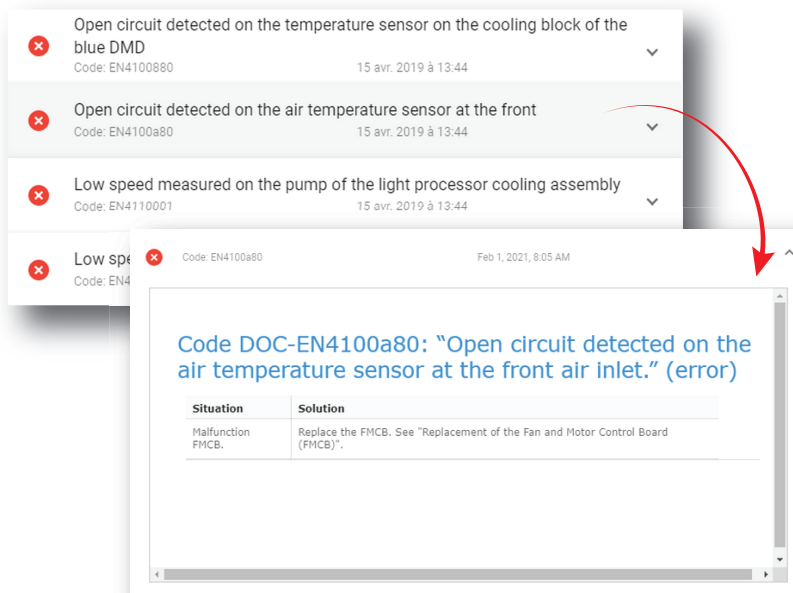

Image 15-7

2. Click on the notification again to view it in minimal view.

## 15.4 Metrics

### Location & access

Menu: Diagnostics > Monitoring > Metrics

Level: Administrator, Service technician, Show manager

### Overview

All measured values available in the device are listed in this menu.

Values are grouped by type (current, pressure, runtime, speed, temperature, voltage).



This panel is read only.

Image 15–8

### Available Filters

Filter	Description
Search	See section <a href="#">“Search”, page 58</a> to obtain more details concerning the Search functionality.
Type selection	Allows to select which types of sensor will be displayed (current, pressure, speed ...). See section dedicated to the type selection below to obtain more information.
Types in alphabetical order / reverse alphabetical order	Allows to display the selected type list in alphabetical order or reverse alphabetical order. Order of sensor names in each type stay identical. Only the order of types is impacted with this filter.
°C / °F	Allows to display temperature degrees Fahrenheit (°F) or Celsius (°C).



## How to select/unselect sensor types to display

1. Click **type chooser** icon (located at right on the top bar of the list)

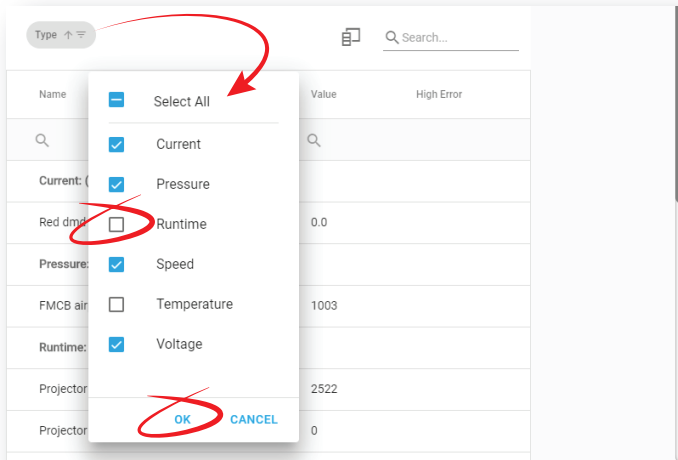

Image 15-9

2. Select the types of sensors you want displayed (or hidden) by switched on (or switched off) the check boxes located at right of each type.
3. Click **OK** to validate and close the pop-up.  
Selected types are now displayed.

## Additional columns

When available, additional information could be displayed by adding supplemental columns:

- High Error: indicates the maximum authorized threshold for this sensor. An error is generally raised by the system when this limit is exceeded.
- Low Error: indicates the minimum authorized threshold for this sensor. An error is generally raised by the system when this limit is exceeded.
- High Warning: indicates limit value above which the system raised a warning to indicate possible issue with this sensor.
- Low Warning: indicates limit value under which the system raised a warning to indicate possible issue with this sensor.

## How to add/remove column

1. Click **Column chooser** icon (located on the top left, near the *Search* icon)  
The *Column Chooser* pop-up is displayed.

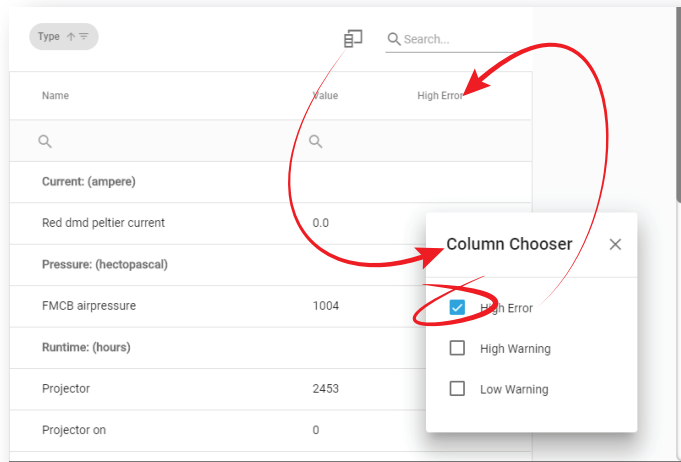

Image 15-10 Add column

2. Select the columns you want add (or remove) by switched on (or switched off) the check boxes located at right.  
Columns are automatically added (or removed) in the menu.
3. Use the **X** (cross) to close the pop-up.

# Diagnostics - Analysis

# 16

16.1 Self test .....	316
16.2 Diagnostic package .....	317
16.3 Reading a diagnostic package .....	318

## About Diagnostic analysis

Menus available in this section contain analysis tools useful to evaluate projector status. Self test menu allows to run predefined test procedures. Diagnostic package menu allows to create one zip file with all logging, version and diagnostics info. A part of this section is also dedicated to explaining “How to read out a diagnostic package” with a cloud application.

## 16.1 Self test

### Location & access

Menu: Diagnostics > Analysis > Self test

Level: Administrator, Service technician

### About self test

This menu allows to select and execute one or several tests in the list of tests in order to evaluate projector status.

### How to run self test

1. While in *Diagnostics > Analysis > Self test*, check the check box **Select all** (reference 1).

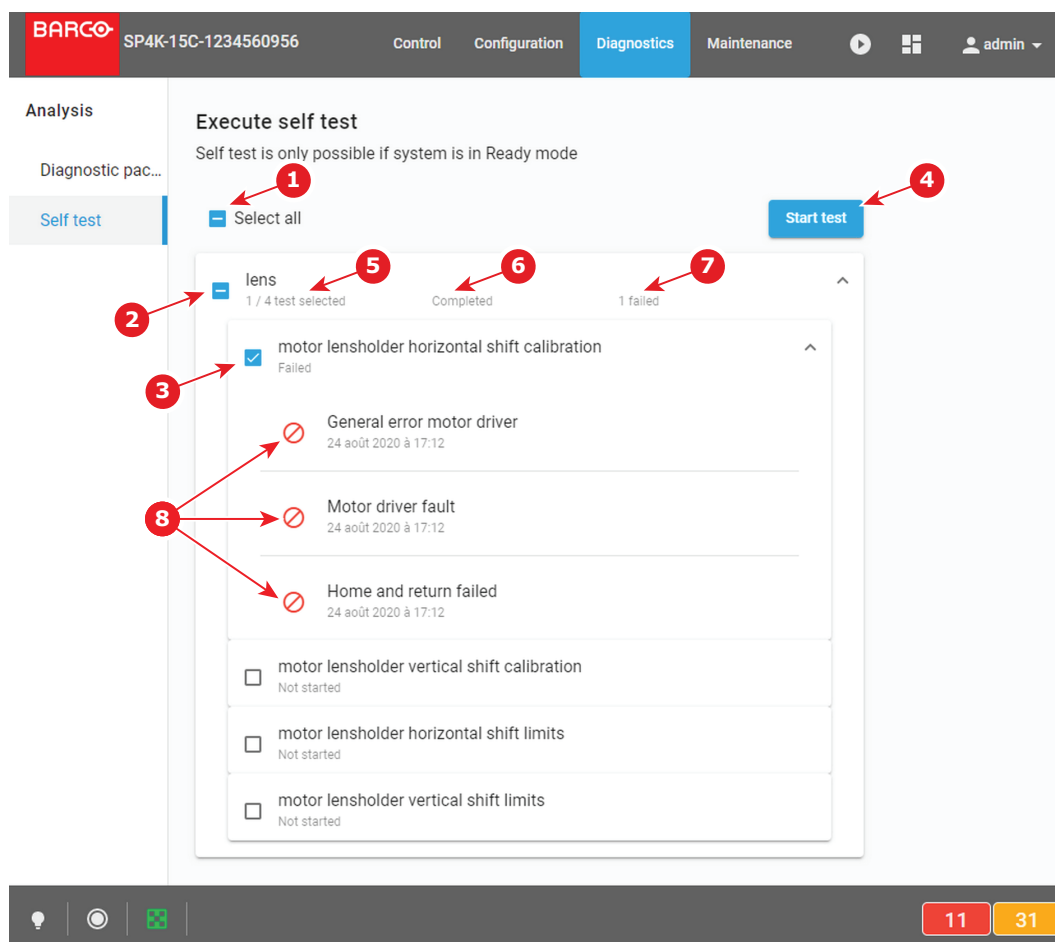

Image 16-1

All tests are selected.

or

use various check boxes (reference 2 and 3) to select (or deselect) a group of tests or a specific test. Number of selected tests is displayed in each group of test (reference 5).

2. Click **Start test** (reference 4) to run self tests.

A confirmation window is displayed.

3. Click **Ok** to continue.

**Start test** button (reference 4) is replaced by **Stop** button and the test starts. Test could be interrupted at anytime by clicking on **Stop** button.

4. After few moments (depending to de kind of tests), status (reference 6) and error (reference 7) of each test is updated.
5. Click on specific test to expand it and obtain more details (reference 8).

## 16.2 Diagnostic package

### Location & access

Menu: Diagnostics > Analysis > Diagnostic package

Level: Administrator, Service technician

### About a diagnostic package

A zip file with all diagnostic files and relevant projector properties inside is created and can be sent to the service technician for further analyze.

### Downloading a diagnostic package

1. While in *Diagnostics > Analysis > Diagnostic package*, click **Download** (reference 1).

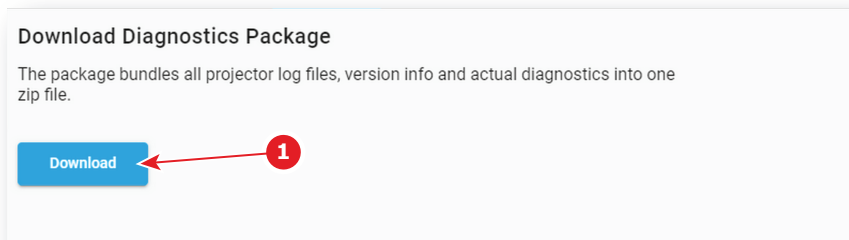

Image 16-2

The diagnostic package is being created and will be downloaded on your local PC in your default download directory.

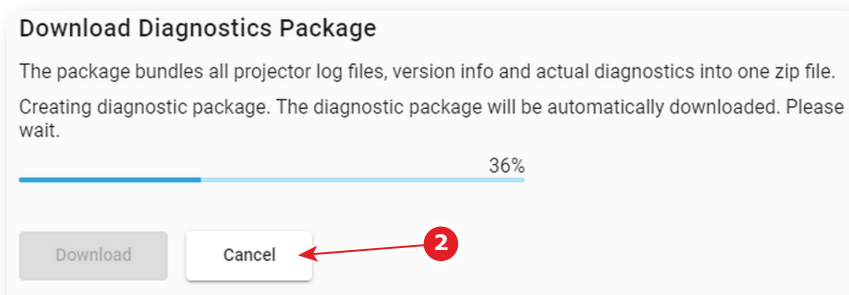

Image 16-3

2. Click **Cancel** (reference 2) allows to abort download.  
Diagnostics Package creation continue, but it will not downloaded on local PC.

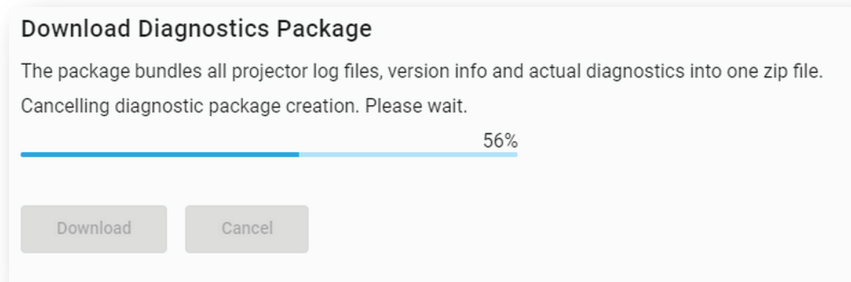

Image 16–4

## 16.3 Reading a diagnostic package

### What can be done

Barco created a cloud application to read out the content of a diagnostic package.

Take into account in order to read a diagnostic package – you require a diagnostic package. For more info on creating a diagnostic package, see “[Diagnostic package](#)”, page 317.

### How to read out a diagnostic package

1. Browse to the [barco.com/mybarco](http://barco.com/mybarco). Click on *myBarco* and login to get access to secured information. Registration is necessary.

If you are not yet registered, click on *New to myBarco* and follow the instructions. With the created login and password, it is possible to login and access the web analyzer tool.

2. on the myBarco dashboard, click on *My Support > Digital Cinema > Web Analyzer*.



*Tip:* You can bookmark the resulting page for quick access in the future.

3. Login with your *myBarco* credentials.

The Web Analyzer main page will be displayed.

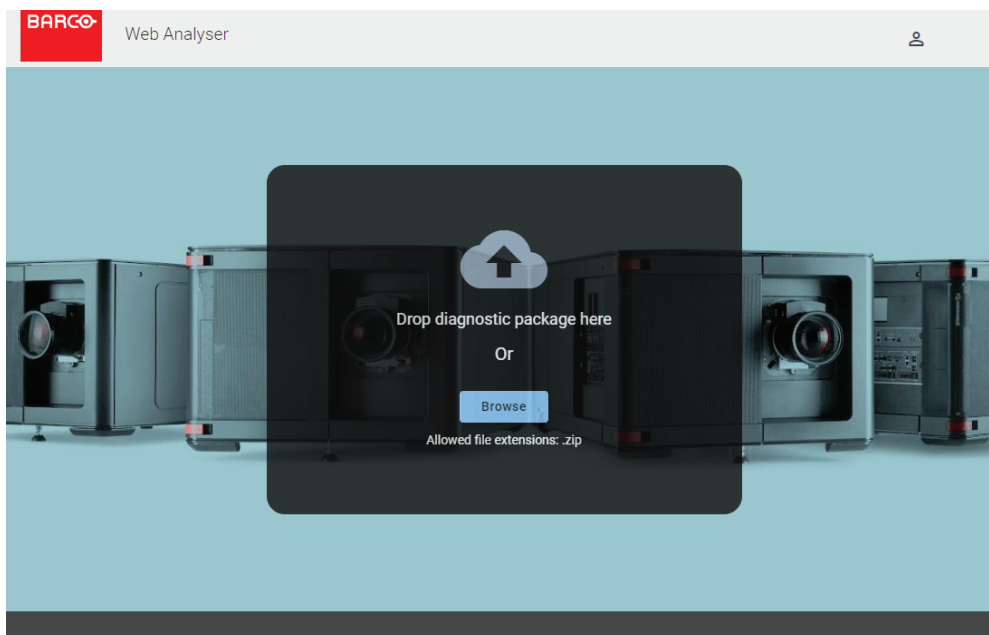

Image 16–5 Web Analyser

4. Drop your created diagnostic package on the *Web Analyzer*

or

click on browse and browse to the diagnostic package.

The package will be analyzed and graphical presentation will be opened in the *Web Analyzer* tool.

The screenshot displays the BARCO Web Analyzer interface for device SP4K-15C R9008822. The dashboard is organized into several sections:

- NOTIFICATIONS (UTC):** Shows two warning categories: 'Board Warnings' (1) and 'Environment Warnings' (9).
- STATUS:**
  - Light source: Off
  - System state: Ready
  - Dowser: Closed
  - Test pattern: Off
- LENS CALIBRATION:**
  - Shift horizontal: NA
  - Shift Vertical: NA
  - Unknown: Unknown
- SETTINGS:**
  - Input: <DIRECT>
  - 3D: No3D.3D
  - MCGD1: measured.MCGD
  - MCGD2: <DEFAULT>
  - PCF: DCDM\_XYZ\_auto.PCF
  - Screen: FullScreen.SCREEN
  - TCCD1: TCCD2
  - DCDM\_XYZ\_auto.PCF: <DEFAULT>
  - Source: DCDM\_XYZ\_auto.PCF
  - Timezone: UTC
  - Lens: Non-motorized lens
- NETWORK:**
  - Host name: SP4K-15C-250
  - Default gateway: 10.241.82.1
  - IP address: 10.241.82.243
  - Subnet mask: 255.255.254.0
- LICENSE:**
  - HDMI2.0-HDR: 78755 hrs left
  - 87673 hrs total
- INFORMATION:**
  - Firmware version: 1.1.5-rc-n260
  - Log information: Nov 13, 2018 - Dec 10, 2019
  - ICP-D serial number
  - Projector serial number
  - [Firmware History](#)

Package creation date: Dec 10, 2019, 1:06:10 PM (UTC)

Image 16–6 Web Analyzer result





# Maintenance

# 17

17.1	Software update .....	322
17.2	Service mode .....	325
17.3	Backup and restore.....	325
17.4	Raid Storage .....	332
17.5	Laser management.....	335

## About this menu

This chapter explains how to perform a software update, to create a full system backup and to restore this backup. Next, a RAID initialization and a file system check can be executed.

## 17.1 Software update

### Location and access

Menu: Maintenance > Software update

Level: Administrator

### Overview

This menu provides information concerning the projector software version (version history, current status of update) and allows upgrade device with a software package.

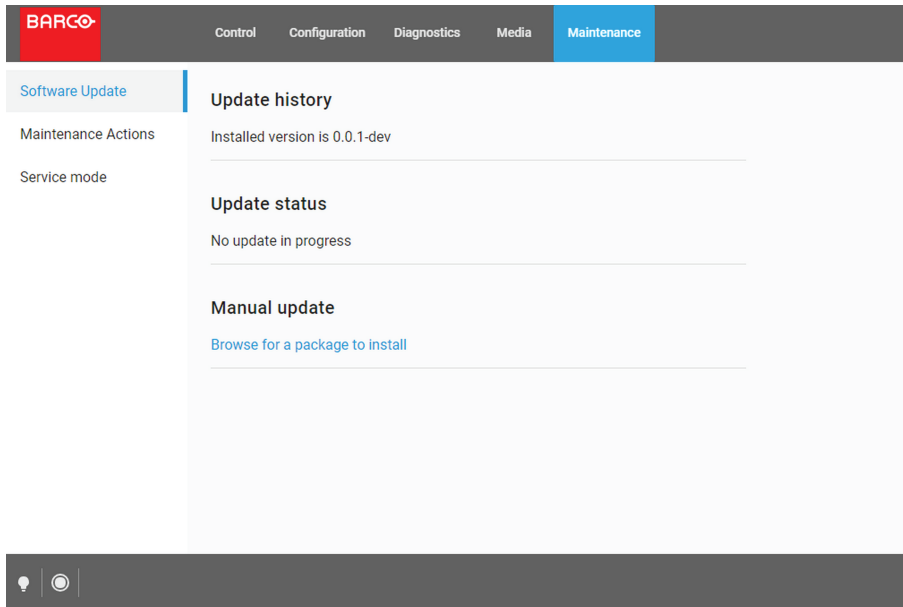



Image 17–1 Example of the Software update menu

Menu item	Explanation
Update History	Indicates the installed software version
Update Status	Indicates if an update is ongoing.
Manual Update	Provides the options for installing an update

### How to update the software

1. Download the latest firmware from the Barco website. Click on *myBarco* and login to get access to secured information. Registration is necessary.

If you are not yet registered, click on *New to myBarco* and follow the instructions. With the created login and password, it is possible to login where you can download the software.

 **Note:** Keep in mind to unzip the package. Only \*.fw files can be selected for software updates.

2. In the Software Update menu, click *Browse for a package to install*.

An *Open* browse window is prompted.

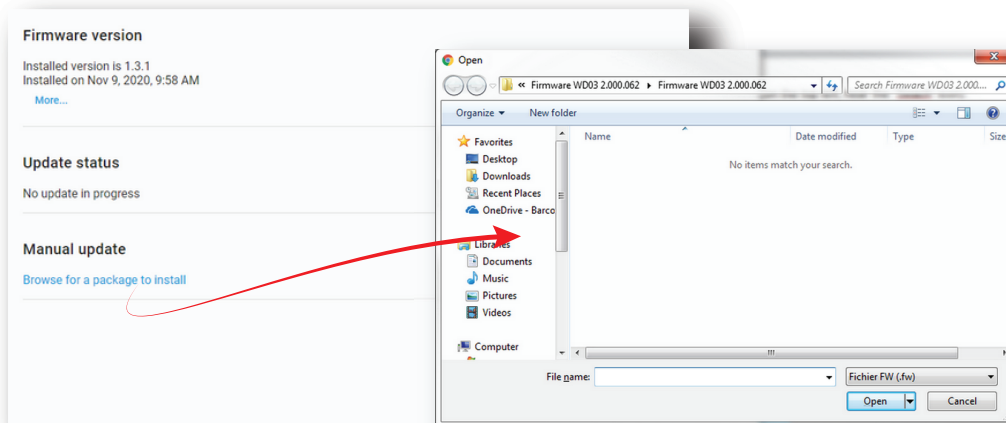

Image 17-2

3. Select the file downloaded from the Barco website.  
The selected file will be mentioned under *Manual update*.

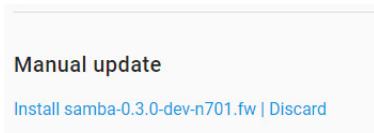



Image 17-3 Example of an update package

4. Click **Install** and confirm.  
The software update will start.

 Take into account that the projector will be rebooted automatically in order to complete the installation and configuration process.

### How to update the software via USB device

1. Download the latest firmware from the Barco website. Click on *myBarco* and login to get access to secured information. Registration is necessary.

If you are not yet registered, click on *New to myBarco* and follow the instructions. With the created login and password, it is possible to login where you can download the software.

 *Note:* Keep in mind to unzip the package. Only \*.fw files can be selected for software updates.

2. Plug a USB device with the downloaded file into the USB port of the Cinema Controller.

 *Note:* The USB device should be formatted in FAT-32. It may only contain the firmware file in the root level of the device.

The USB device will be detected and a window will prompt in the Web Communicator.

3. Click Proceed to have the image added in the Manual update section of the page.

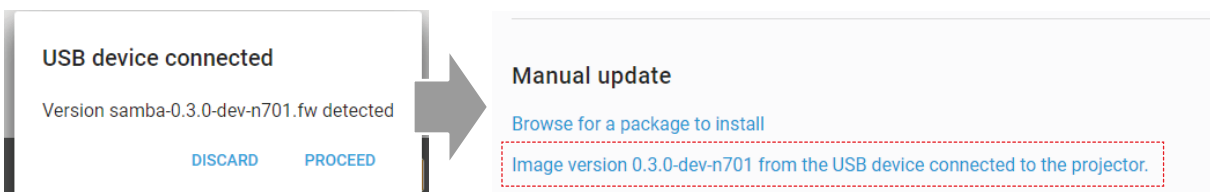

Image 17-4 Example of a software package inserted via USB device

4. Click “Image [name] from the USB device connected to the projector” and confirm.

The software update will start.

### Update progress explanation

The update will proceed as follows:

1. The software package will be installed on the projector.

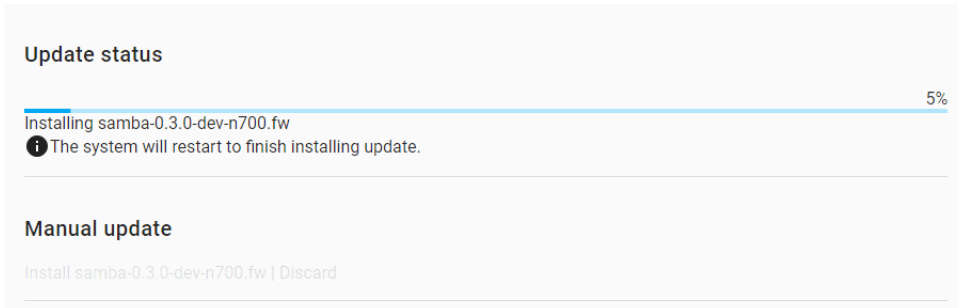

Image 17-5 Example of an update in progress

2. Once the software package has been installed, the following message will be prompted and the projector will reboot.

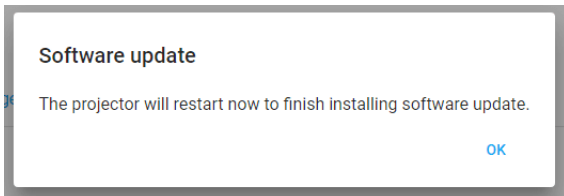

Image 17-6 Example of the prompted reboot message

3. **Take note:** While rebooting, you will lose connection to the projector.
4. Once rebooted, every projector component will be updated to the version included in the software package. Take into account that it might take a while until all components have been updated.

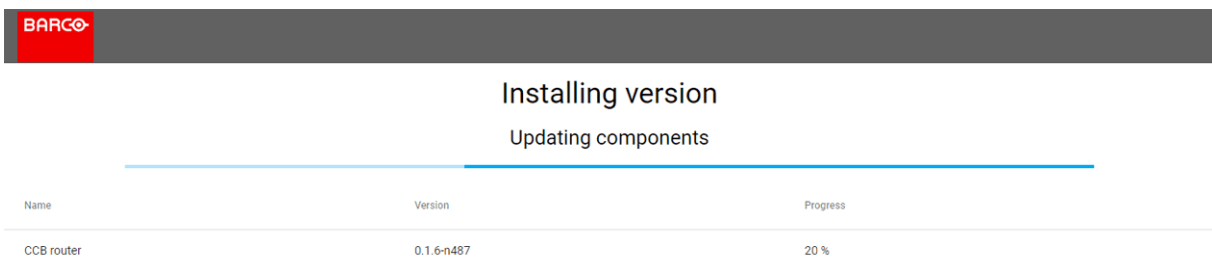

Image 17-7 Example of the components update page.

5. Once every component has been updated, you will be redirected to the Web Communicator login page.

### In case of error

This supplemental menu item appears to indicate an error if an error was raised during the software update (e.g. *\*Selected package for update is invalid*).



Any triggered errors will also be visible in the notification menu. For more details on error and , please refer to “Notifications”, page 309.

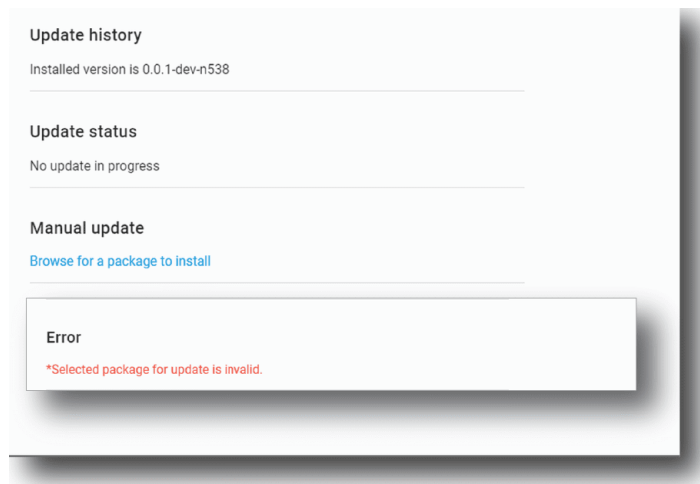

Image 17–8

## 17.2 Service mode

### Location & access

Menu: Maintenance > Service mode

Level : Administrator, Service technician

### About service mode

The service mode is only necessary when a service intervention must be done on the light source. For more information, see “*service manual*”.

## 17.3 Backup and restore

### 17.3.1 Download and restore full system backup

#### Location & access

Menu: Maintenance > Backup and restore

Level : Administrator, Service technician

#### What can be done

A backup package allows to create a specific backup which contains all of the custom configuration of a device. It is recommended to create such a backup package (e. g. after initial installation) and store it offline.

Afterwards such a backup package can be restored either

- on the same projector: all data from the backup package can be restored and applied.
- on a different projector: only partial data from the backup package can be restored.

In both cases, service technician decides what he wants to restore (partial or complete restoration).

#### How to download

1. While in *Maintenance > Backup and restore*, click **Download** in the *full system backup pane* (reference 1).

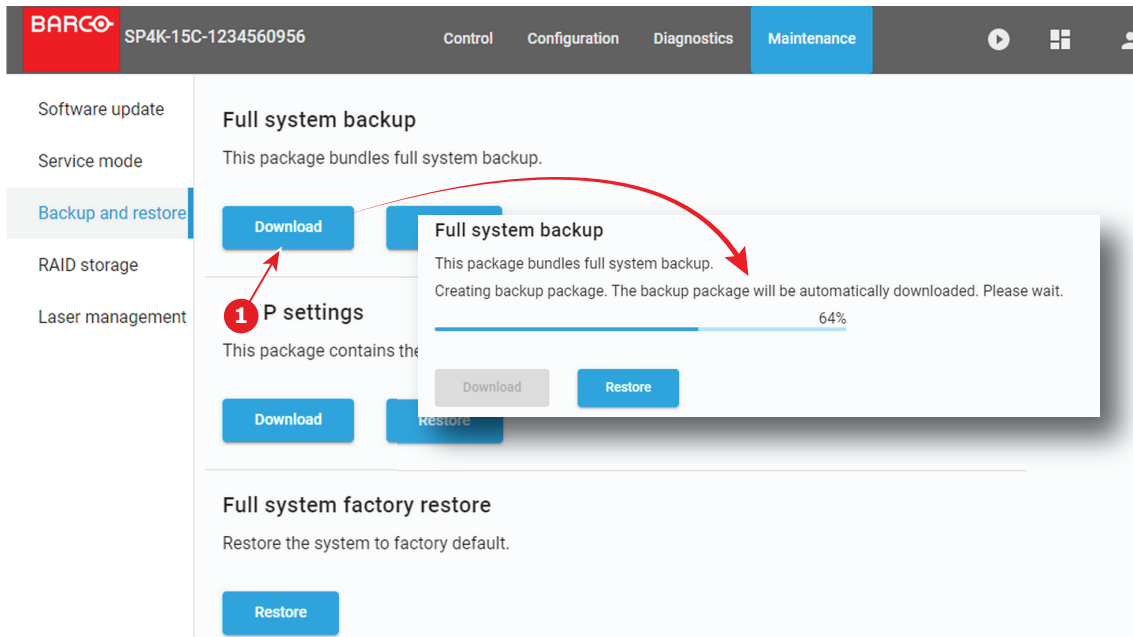

Image 17-9

A full backup tar file is created. The name of file contains the projector type, serial number and a time stamp. E.g. FULL-backup-SP4K-15C-2590153431-2019-04-10T061205Z.tar

The file is stored on your local PC in your default download directory.

## How to restore

1. While in *Maintenance > Backup and restore*, click **Browse** in the *full system backup* pane (reference 1).

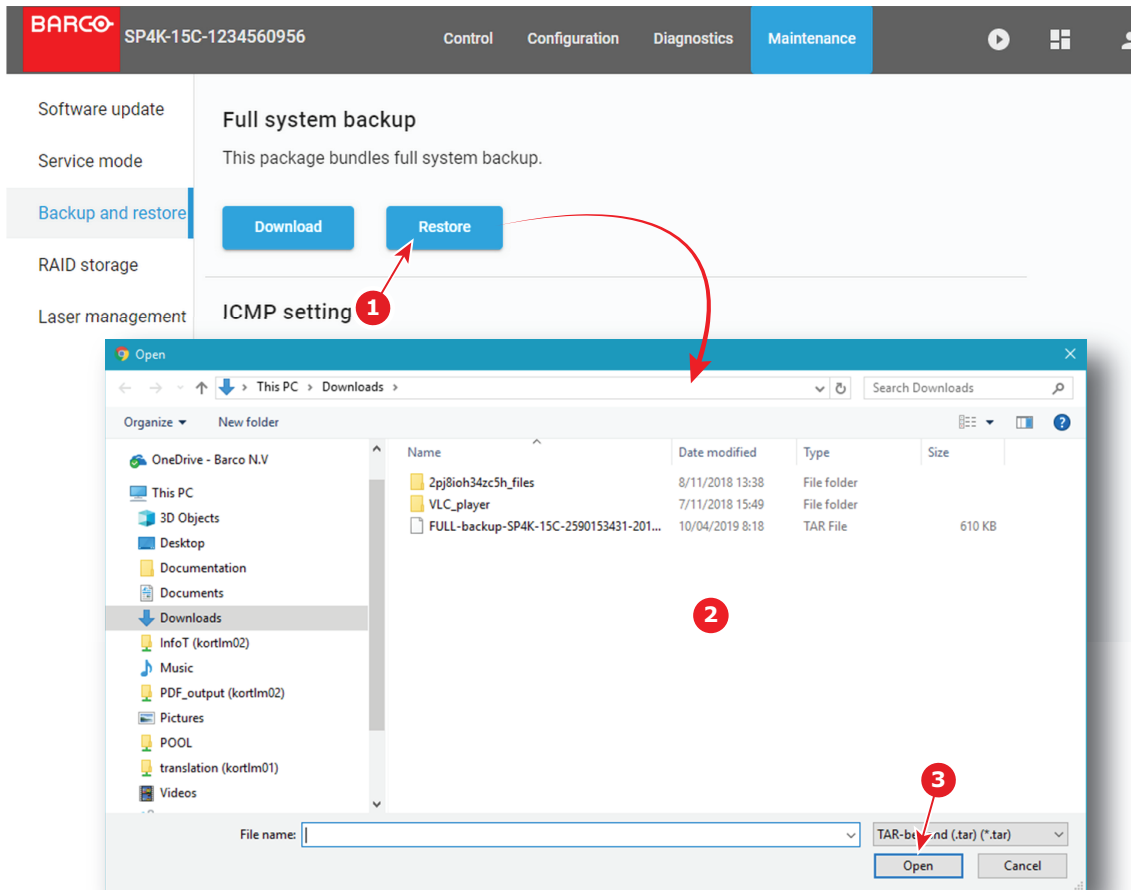

Image 17–10

A browser window opens.

2. Browse to the full backup file (reference 2). A backup file has the extension tar.
3. Click **Open** (reference 3).

A progress bar is displayed to indicate the status of the upload process, then after few moments select settings window is displayed.

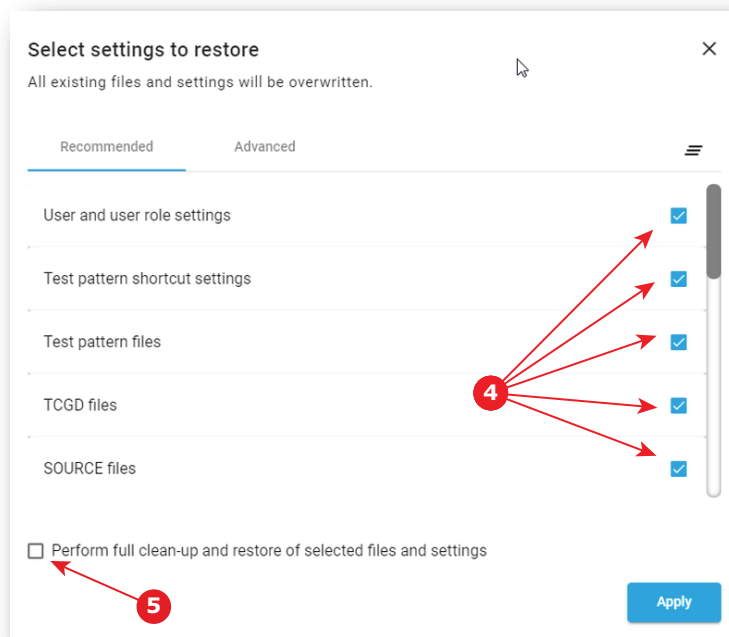

Image 17–11

4. If there are any undesired file selected, deselect the undesired files (reference 4). Check *Perform full clean-up and restore of selected settings* (reference 5) allows to clean up (and restore the default values) of selected files before applying the new settings.

5. Click **Apply**.

Current projector configuration will be overwritten with selected one.

## 17.3.2 Download and restore ICMP settings

### Location & access

Menu: Maintenance > Backup and restore

Level : Administrator, Service technician

### What can be done

Allows to save or restore media player settings by using specific backup package. It is recommended to create such a backup package (e. g. after initial installation) and store it offline.

Such backup package can be use to restore ICMP settings after a material upgrade (e.g. series 2 to series 4) or a replacement of the unit by a new one (e.g. total device failure).

### How to download

1. While in *Maintenance > Backup and restore*, click **Download** in the *ICMP settings pane* (reference 1).



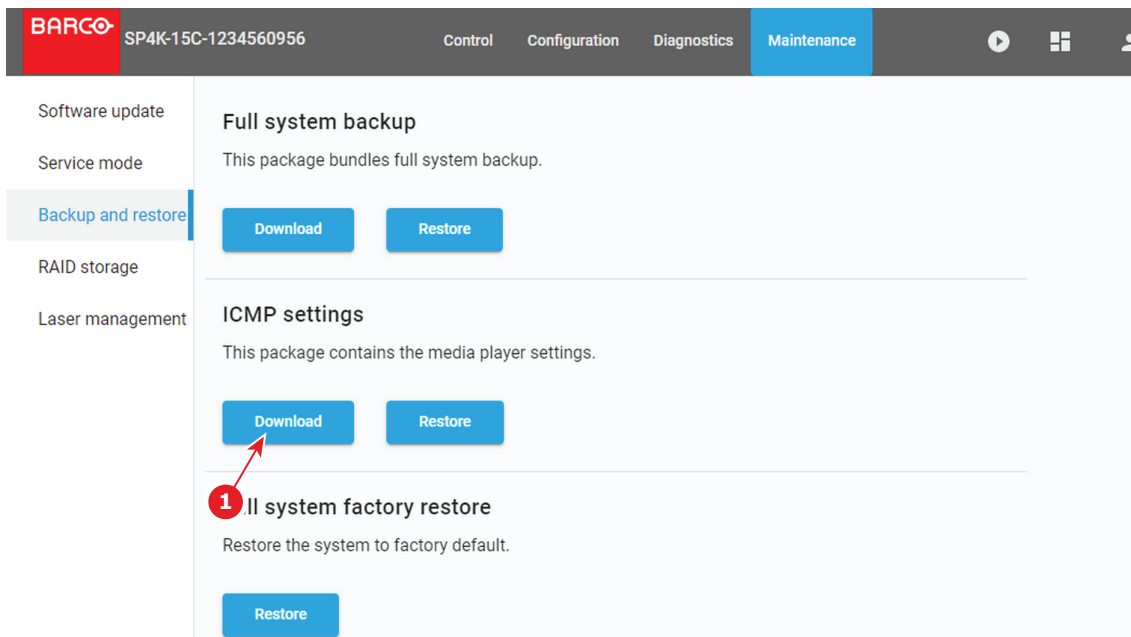

Image 17-12

A setting.xml file is created.

The file is stored on your local PC in your default download directory.

## How to restore

1. While in *Maintenance > Backup and restore*, click **Browse** in the *ICMP settings* pane (reference 1).

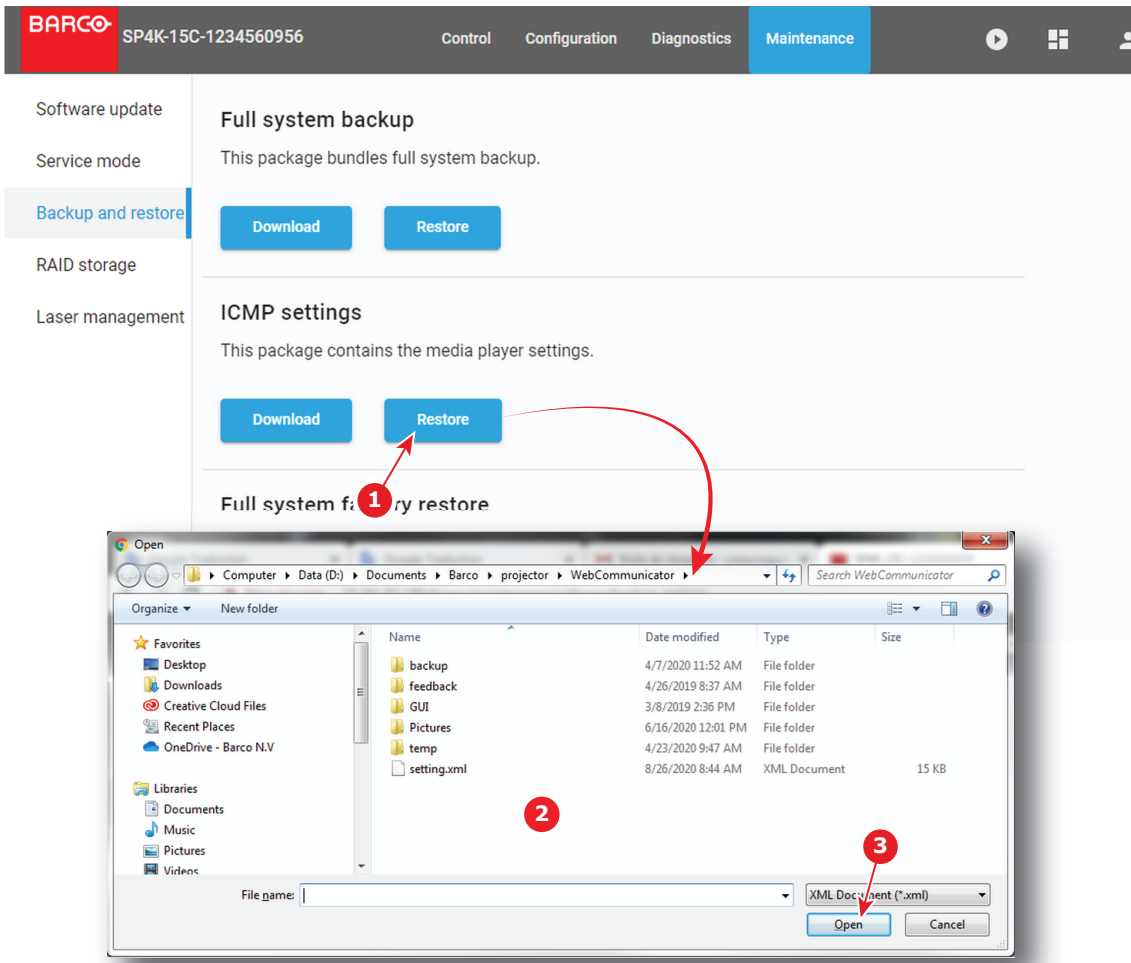

Image 17-13

A browser window opens.

2. Browse to the backup file (reference 2). A backup file has the extension xml.
3. Click **Open** (reference 3).  
A confirmation window is displayed.
4. Click **Ok** to confirm import of ICMP settings (current ICMP configuration will be overwritten).

### 17.3.3 Factory restore

#### Location & access

Menu: Maintenance > Backup and restore

Level : Administrator, Service technician

#### About restoring factory settings

When a factory restore is request, the following is restored:

- restore the mainboard values to defaults
- restore the calibrated mainboard values to factory calibrated values
- restore the ICMP-X to default values
- restore the ICMP-X backup package
- restore the "default clone package"

The restore settings feature allows to replace the current settings with the default factory values.

Overview of the ICMP-X settings:

<b>Global setting</b>	<b>Description</b>	<b>Default value</b>
Auditorium name	Name of the auditorium displayed on the user interface (front end application)	Auditorium
Host name	Name assigned to the ICMP to identify the device in the theater network	Not deleted nor modified when restoring settings
IP address	Parameters that define the network interface	The network parameters are not deleted after restoring settings but the DHCP parameter is enabled.

<b>User setting</b>	<b>Description</b>	<b>Default value</b>
User list	The list of users and their access levels to the ICMP functionalities	Admin → USER_ADMINISTRATOR show → USER_SHOW_MANAGER st →

<b>Server setting</b>	<b>Description</b>	<b>Default value</b>
Server list	The list of servers, remote directories and libraries where the contents are stored	Set to blank (empty)

<b>Player setting</b>	<b>Description</b>	<b>Default value</b>
Audio delay (ms)	Audio delay is used to correct the synchronization between sound and picture	0
Audio output frequency (kHz)	Allows set the sound for the audio output	48000
Video output resolution	Allows set the video resolution of the ICMP (2K or 4K)	Auto

<b>Audio setting</b>	<b>Description</b>	<b>Default value of audio channel label</b>
AES1	AES output 1	CH01, L
AES2	AES output 2	CH02, R
AES3	AES output 3	CH03, C
AES4	AES output 4	CH04, LFE
AES5	AES output 5	CH05, Ls
AES6	AES output 6	CH06, Rs
AES7	AES output 7	CH07, HI
AES8	AES output 8	CH08, VI-N
AES9	AES output 9	CH09, Lc
AES10	AES output 10	CH10, Rc
AES11	AES output 11	CH11, Lrs
AES12	AES output 12	CH12, Rrs
AES13	AES output 13	CH13, DBOX
AES14	AES output 14	CH14, Sync
AES15	AES output 15	CH15
AES16	AES output 16	CH16

Scheduler setting	Description	Default value
Scheduler at startup	Default state of the scheduler at the ICMP startup	The scheduler value doesn't change after restore factory settings
Maximum delay allowed (in mins)	Maximum delay allowed for which the ICMP will attempt to start a scheduled show from its scheduled start time.	10
Preselection Delay (in mins)	Based on this value, the ICMP will attempt to select a scheduled show in advanced for the given values.	30
History length (in days)	Length of the schedule history.	30
Maximum play trigger delay (in seconds)		0

## How to restore

1. While in *Maintenance > Backup and restore*, click **Restore** in the *Full system factory restore* pane (reference 1)

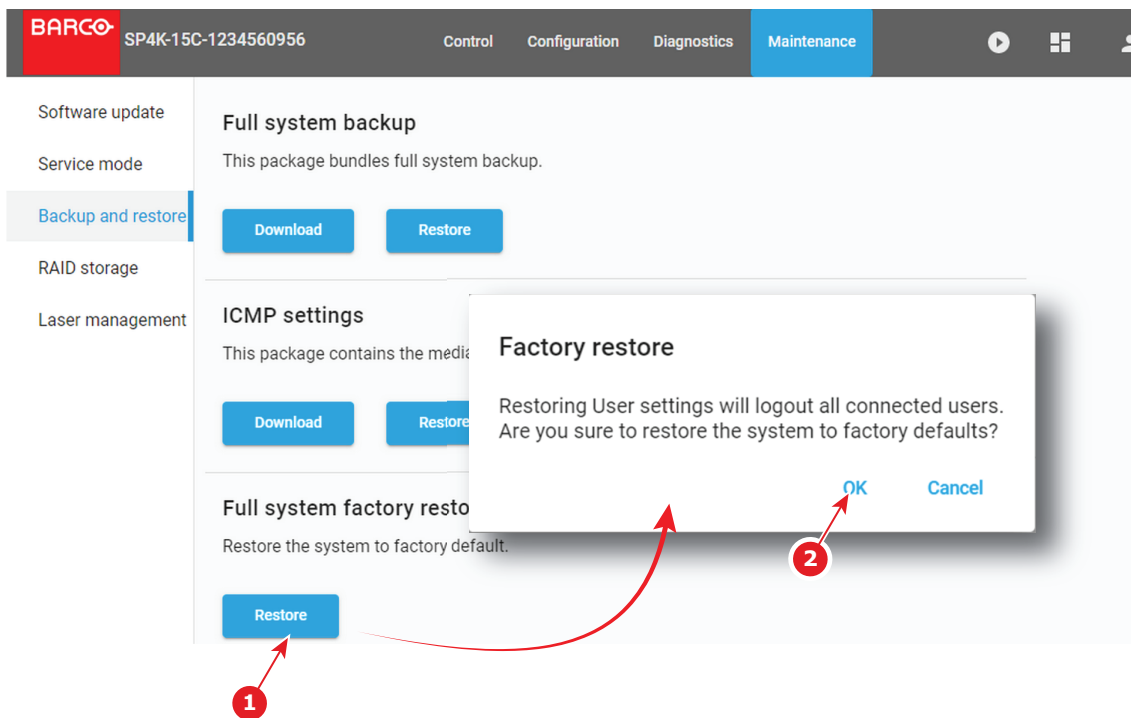

Image 17-14

A Factory restore window opens with a warning that the user settings will be restored and all connected users will be logged out.

2. If you want to continue with the factory restore, click **OK** (reference 2).

## 17.4 Raid Storage

### 17.4.1 Raid status

#### Location & access

Menu: Maintenance > Raid Storage

Level : Administrator, Service technician

## Overview

While in *Maintenance > RAID Storage*, the RAID status can be found in the Raid pane.

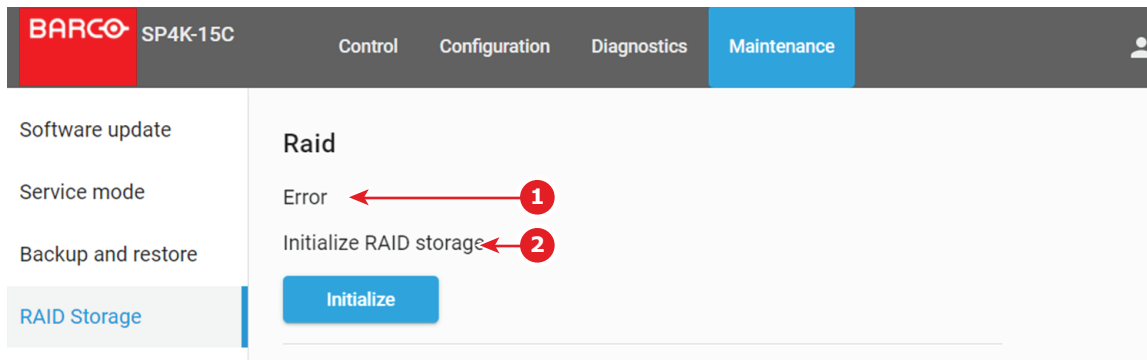

Image 17–15

- Storage state (reference 1)
- RAID status (reference 2)

### 17.4.2 Initialize RAID storage

#### Location & access

Menu: Maintenance > RAID storage

Level : Administrator, Service technician



Inserting a 1TB hard disk in a 2TB system will result in a degraded condition. The 1TB drive will not be adopted in the raid. Only 2 of the 3 drives are active and there is no raid protection in case one of the drives fails. The system will work without redundancy.

Inserting a 2TB hard disk in a 1TB system triggers a rebuild and the 2TB drive is adopted in the raid as a 1TB drive.

#### How to initialize

1. While in *Maintenance > RAID Storage*, click **Initialize** in the Raid pane (reference 1)

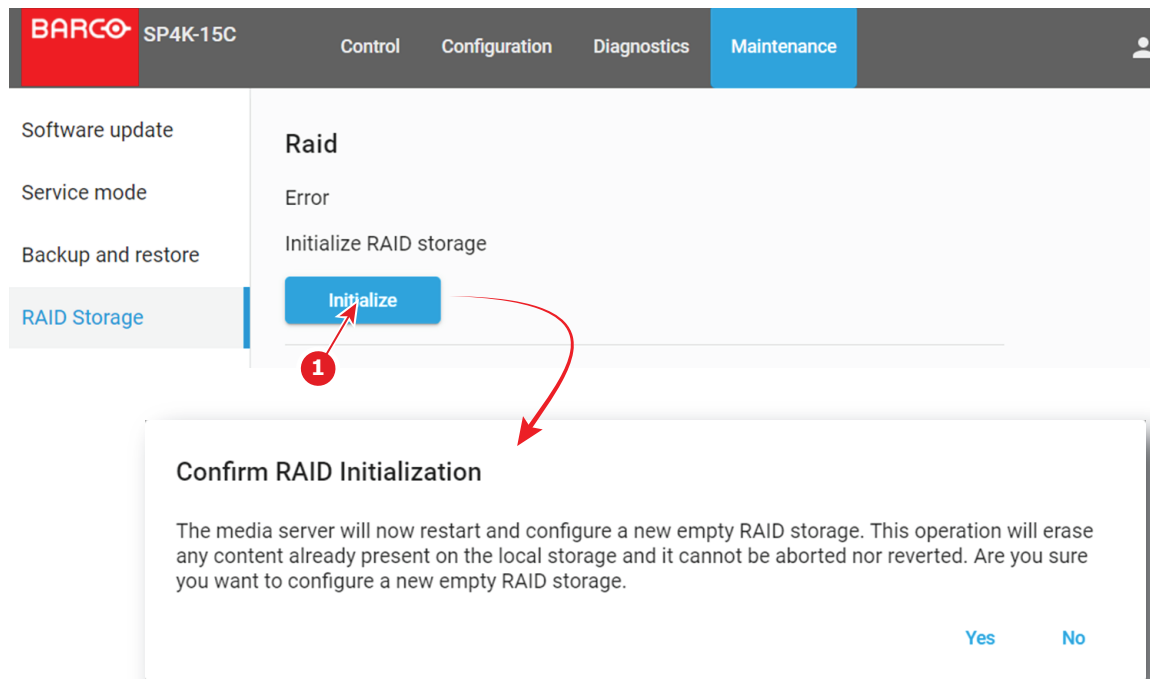

Image 17-16

A confirmation RAID initialization window opens.

RAID initialization erases any content present on the local storage. This process can be aborted nor reverted.

**2.** Are you sure to continue?

▶ If yes, Click **Yes**.

The system will restart and configure a new empty RAID storage. This operation will erase any content already present on the local storage. This operation cannot be aborted nor reverted.

You will see the 3 HDD activity LED's blinking continuously. This means that the file system is being initialized and can take up to 30 minutes! **It is strongly recommended NOT to power down, reset, upgrade or ingest during that period.**

The file system is completely initialized when the 3 HDD activity LED's are off.

▶ If no, click **No** to stop the process.



When mixing 1TB and 2TB drives, error messages will be displayed.

### 17.4.3 File system check

#### Location & access

Menu: Maintenance > RAID storage

Level : Administrator, Service technician

#### File system check

1. While in *Maintenance > RAID Storage*, click **Check** to start a file system check (reference 1).

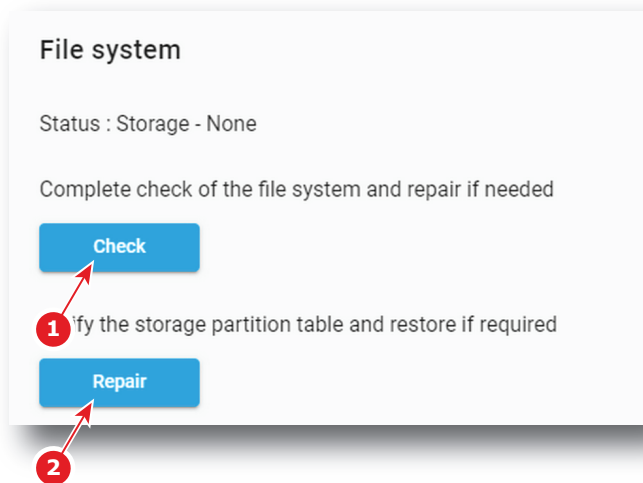

Image 17-17

The system runs a file system check, reports the errors and repairs. This procedure can take several minutes.

## Verify storage partition

1. While in *Maintenance > RAID Storage*, click **Repair** to verify the storage partition table and to restore if necessary (reference 2).

# 17.5 Laser management

## 17.5.1 Laser Bank status

### Location & access

Menu: Maintenance > Laser Management

Level : Administrator, Service technician

### Overview

Depending to the projector model, light source are build up with different Red, Green or Blue 2 or 3 banks laser plates.

While in *Maintenance > Laser Management*, the status of each laser bank can be found by selecting a laser color source (reference 1) then clicking on a laser plate (reference 2) to display banks combined inside.

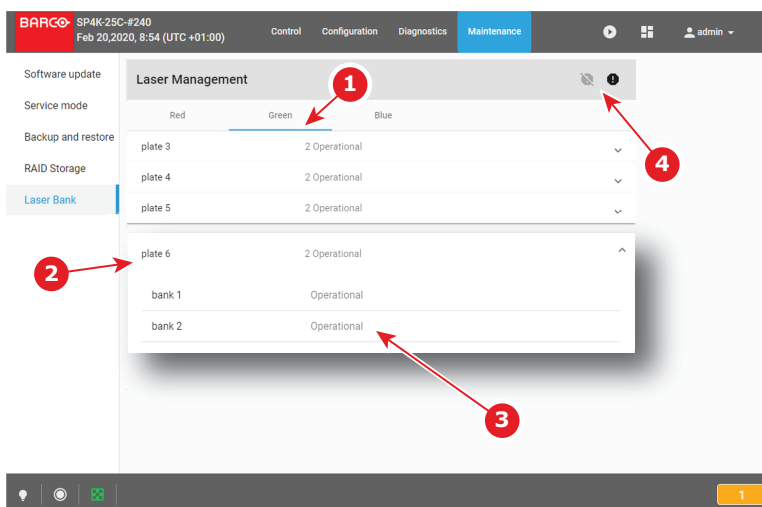

Image 17-18

Status (reference 3) is *Operational* when laser bank is up and running.

If the system detect an issue on a laser bank its status (reference 3) is change to *warning*. A non-functional laser bank doesn't prevent projector operation, but multiple notifications will be triggered regularly.

Use **deactivate** and **activate** buttons (reference 4) to hide/unhide these notifications. When the Laser Bank notifications was deactivated, status (reference 3) of concerned banks is change to *blocked*.



It's recommended to resolve laser bank issues as soon as possible to prevent future issues with the projector and allows providing a complete performance during the show.

## How deactivate/activate Laser Bank notifications

1. While in *Maintenance > Laser Management*, click on *deactivate* button (reference 2) to hide notifications triggered by system when some laser banks are in *warning* status (reference 1).

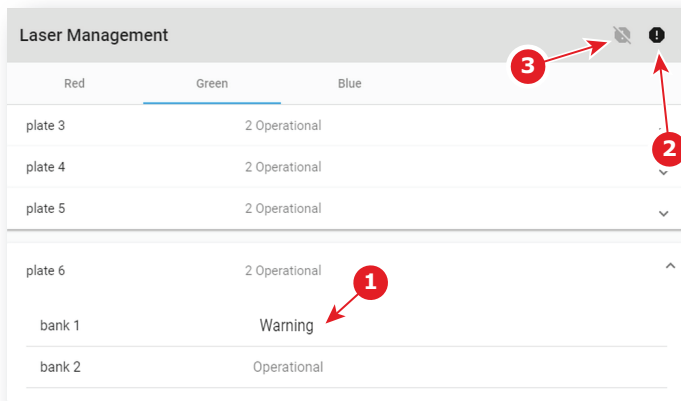

Image 17–19

Status of all Laser banks currently in *Warning* status changes to *Blocked* and related notifications are no longer raised.

2. Click on *activate* button (reference 3) to activate again notifications triggered by system when some laser banks are not non-functional.

All Laser banks currently in *Blocked* status changes to *Warning* status and notifications related to these issues are send again.



# Preventive maintenance actions

# 18

18.1	1 month maintenance actions .....	338
18.2	3 month maintenance actions .....	338

## Maintenance program

The maintenance program is subdivided in time frames. The maintenance actions described in this chapter can be done by a trained projectionist. Note that there are also annually and 4 yearly maintenance actions (not included in this manual) which must be done by certified service personnel who are familiar with potential hazards of the product and all product safety checks. Contact your service partner for more information about maintenance services.

## 18.1 1 month maintenance actions

### MAINTENANCE TYPE A (perform every month)



The 1 month maintenance actions, listed below, may be performed by a trained projectionist who is familiar with potential hazards associated with the product.

No.	Maintenance action	Remarks
1	Check the surface of the lens output side for dust. (it is not needed to remove the lens from the projector). Only clean if necessary.	Clean the lens output side in case dust is clearly visible upon the surface. <b>Note:</b> if the lens was removed from the projector, a manual "Lens Home & Return" action must be executed to calibrate the position of the lens in relation to the Lens Holder. This way the references of the existing 'lens files' remain valid. See user guide for more information.
2	Check the porthole (both sides) for dust.	Clean the porthole in case dust is clearly visible upon the surface. Use an optical cloth.

## 18.2 3 month maintenance actions

### MAINTENANCE TYPE B (perform every three months)



The 3 month maintenance actions, listed below, may be performed by a trained projectionist who is familiar with potential hazards associated with the product.

No.	Maintenance action	Remarks
1	Clean the front/back/side air inlet vents.	Use a vacuum cleaner.
2	Clean the housing of your projector.	Removal overall dust accumulation on projector covers. See cleaning instructions in this manual.
3	Verify the clock of the ICMP-X with a real time clock. Correct the internal clock if it has drifted. <b>Note:</b> This action is not required if NTP has been configured on the ICMP-X. In this case NTP will automatically correct the internal clock.	See user guide for detailed instructions on NTP and clock correction.

# Maintenance procedures

# 19

19.1	Checking the front filters.....	340
19.2	Checking the rear dust filters .....	341
19.3	Checking the LDM dust filter .....	342
19.4	Vacuum cleaning of the dust filters .....	342
19.5	Washing and drying the dust filters .....	343
19.6	Cleaning the lens.....	344
19.7	Cleaning the exterior of the projector .....	345
19.8	Authorization to clear a security warning on the projector .....	345



**WARNING:** All procedures described in this chapter may only be performed by TRAINED PROJECTIONISTS or qualified SERVICE PERSONNEL.

## About this chapter

This chapter describes several maintenance procedures for your Freya projector.

## 19.1 Checking the front filters

### Required tools

No tools required.

### How to check the front dust filters

1. Remove the front cover. For more info, refer to [“Removal of the front cover”, page 348.](#)
2. Detach the dust filter from the holder.

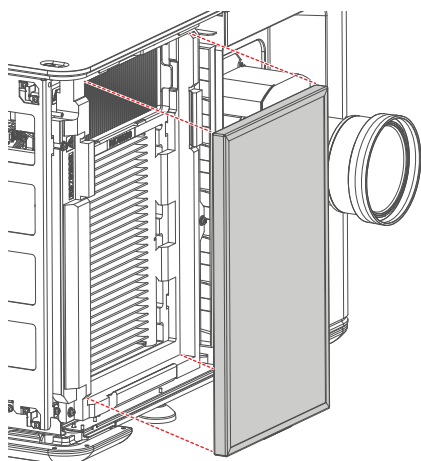

Image 19-1

The DMD filter becomes visible.

3. Detach the DMD filter from its holder.

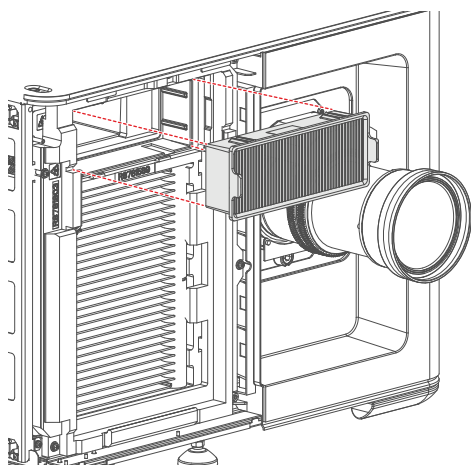

Image 19-2

4. Check the “air in” side of the dust filters for **dust** and/or **grease**.

In case the filter is contaminated with grease wash and dry the dust filter. See cleaning procedure [“Washing and drying the dust filters”, page 343.](#)

In case the filter contains dust but doesn't feel greasy then vacuum clean the dust filter. See procedure [“Vacuum cleaning of the dust filters”, page 342.](#)



**Note:** Grease on the filter can build up after several months in an environment contaminated with greasy air. Note that areas where popcorn is consumed are subject to greasy air.



**Tip:** Take into account that the time needed to dry the dust filters may be 24 hours or more. For that, it's recommended to have a second set of dust filters which can be used while cleaning the first set.

- Place clean dust filters in the filter holder. Make sure the filters are fully inserted and respect the airflow of the filter, which should be pointed inwards.

**!** **Caution:** UNDER NO CIRCUMSTANCES SHOULD WET FILTERS BE INSTALLED BACK INTO THE PROJECTOR. THIS CAN HAVE SERIOUS SAFETY CONSEQUENCES AS WELL AS JEOPARDIZE THE INTERNAL OPTICS OF THE SYSTEM.

- Mount the front cover. For more info, refer to [“Mounting the front cover”](#), page 350.

## 19.2 Checking the rear dust filters

### Required tools

No tools required.

### How to check the rear dust filters

- Remove the rear cover. For more info, refer to [“Removal of the rear cover”](#), page 348.
- Detach the desired dust filter (left, right or both) from the holder.

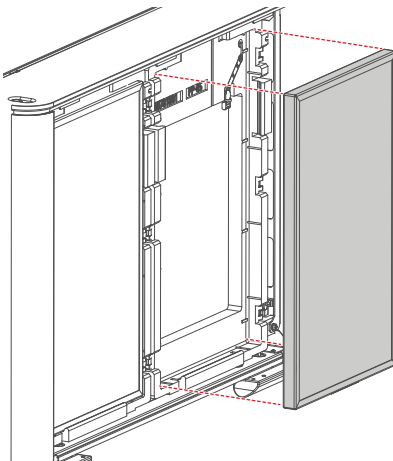

Image 19-3

- Check** the “air in” side of the dust filter for **dust** and/or **grease**.

In case the filter is contaminated with grease wash and dry the dust filter. See cleaning procedure [“Washing and drying the dust filters”](#), page 343.

In case the filter contains dust but doesn't feel greasy then vacuum clean the dust filter. See procedure [“Vacuum cleaning of the dust filters”](#), page 342.



**Note:** Grease on the filter can build up after several months in an environment contaminated with greasy air. Note that areas where popcorn is consumed are subject to greasy air.



**Tip:** Take into account that the time needed to dry the dust filters may be 24 hours or more. For that, it's recommended to have a second set of dust filters which can be used while cleaning the first set.

- Place a clean dust filter in the filter holder. Make sure the filter is fully inserted and respect the airflow of the filter, which should be pointed inwards.

**!** **Caution:** UNDER NO CIRCUMSTANCES SHOULD WET FILTERS BE INSTALLED BACK INTO THE PROJECTOR. THIS CAN HAVE SERIOUS SAFETY CONSEQUENCES AS WELL AS JEOPARDIZE THE INTERNAL OPTICS OF THE SYSTEM.

- Mount the front cover. For more info, refer to [“Mounting the rear cover”](#), page 349.

## 19.3 Checking the LDM dust filter

### Required tools

No tools required.

### How to check the LDM dust filters

1. Check the exact location of the LDM dust filter. It is located on the operator side, underneath the LDM and the elca box.
2. Detach the dust filter from the holder and slide it out.

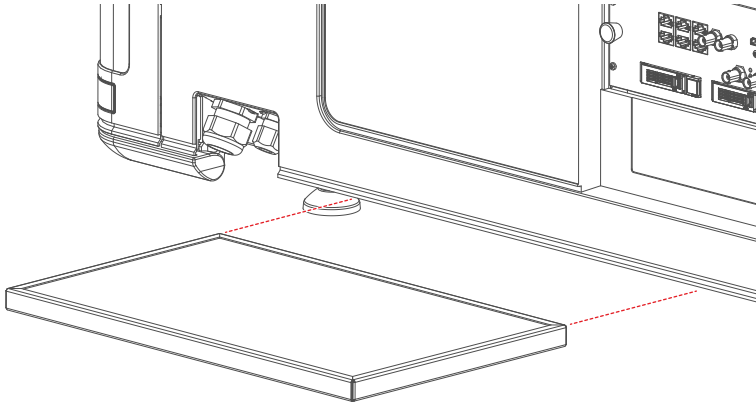

Image 19-4

3. **Check** the “air in” side of the dust filter for **dust** and/or **grease**.

In case the filter is contaminated with grease wash and dry the dust filter. See cleaning procedure “[Washing and drying the dust filters](#)”, page 343.

In case the filter contains dust but doesn't feel greasy then vacuum clean the dust filter. See procedure “[Vacuum cleaning of the dust filters](#)”, page 342.



**Note:** Grease on the filter can build up after several months in an environment contaminated with greasy air. Note that areas where popcorn is consumed are subject to greasy air.



**Tip:** Take into account that the time needed to dry the dust filters may be 24 hours or more. For that, it's recommended to have a second set of dust filters which can be used while cleaning the first set.

4. Place a clean dust filter in the filter holder. Make sure the filter is fully inserted and respect the airflow of the filter, which should be pointed inwards.



**Caution:** UNDER NO CIRCUMSTANCES SHOULD WET FILTERS BE INSTALLED BACK INTO THE PROJECTOR. THIS CAN HAVE SERIOUS SAFETY CONSEQUENCES AS WELL AS JEOPARDIZE THE INTERNAL OPTICS OF THE SYSTEM.

## 19.4 Vacuum cleaning of the dust filters

### When to vacuum clean the dust filters?

The dust filters should be checked every month. If the filters are contaminated with dust then cleaning the filters with a vacuum cleaner should be sufficient. In case the filters feel greasy these must be washed. See cleaning procedure “[Washing and drying the dust filters](#)”, page 343.



Grease on the filter can build up after several months in an environment contaminated with greasy air. Note that areas where popcorn is consumed are subject to greasy air.



This procedure assumes that the dust filters are removed from their slots.

## Required tools

Vacuum cleaner with soft brush suction nozzle.

## How to vacuum-clean the dust filter?

1. Carefully vacuum the air inlet side of the dust filter. Use a vacuum cleaner with a soft brush suction nozzle. The air inlet side of the dust filter is the side which is surrounded with a glue edge.

 *Tip:* Lightly tap the filter on its dusty side to expel heavy dust contamination.

 *Tip:* Compressed air is also permitted to clean the filters but take care not to damage them.

 *Caution:* Do not damage the dust filter. Replace damaged dust filters immediately.

# 19.5 Washing and drying the dust filters

## About filter washing and drying

For environments where popcorn grease and such can contaminate the filters, Barco advises the client to purchase one extra set of filters to cover drying time, as well as taking following extra precautions and instructions pertaining to filter cleaning and drying.

## Cleansing agent

To clean sticky, greasy dust filters we suggest usage of **Sodium carbonate** crystals ( $\text{Na}_2\text{CO}_3$ ). Sodium carbonate (Often called **washing soda**, **soda crystals**, or **sal soda** in the detergent section of stores) is widely used to effectively remove oil, grease, alcohol stains ... The product itself is relatively safe, sodium carbonate is used in toothpastes and as a food additive (E500). Potential Hazards are described in the section "Hazards", page 387.

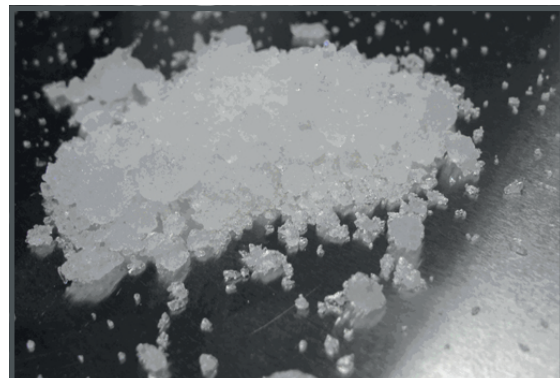

Image 19-5 Sodium carbonate crystals.



This cleaning procedure assumes that the filters are already removed from their slots.



Take into account that the time needed to dry the dust filters may be 24 hours or more. For that, it's recommended to have a second set of dust filters which can be used while cleaning the first set.

## Required tools

- Bucket with hot water
- Sodium carbonate, 30 gram (handful) per liter hot water

## How to wash and dry the dust filters?

1. Make a solution with a ratio of 30 gram (a handful) sodium carbonate to 1 liter **hot water**.

2. Soak the dust filters in the solution for **30 to 60 minutes**. The grease should be dissolved after 1 hour.
3. If the dust filter is still clogged repeat this procedure from step 1.
4. Rinse the dust filters with clean water to flush all grease residue away.
5. Shake out all excess liquid by repeatedly swinging the filter to-and-fro in a centrifugal action.
6. Then allow the filters to **dry thoroughly**.



*Note:* Drying time of the dust filters can be up to 24h or more. Drying time can be shorter when being done in a well-ventilated area.



*Tip:* To speed-up drying, allow the filter(s) to dry at 50°C max in a well ventilated room.



**CAUTION:** UNDER NO CIRCUMSTANCES SHOULD WET FILTERS BE INSTALLED BACK INTO THE PROJECTOR. THIS CAN HAVE SERIOUS SAFETY CONSEQUENCES AS WELL AS JEOPARDIZE THE INTERNAL OPTICS OF THE SYSTEM.



**CAUTION:** Do not install/use damaged dust filters. Replace damaged dust filters immediately with new dust filters of the same type. See <https://my.barco.com> for the correct replacement part.

## 19.6 Cleaning the lens



To minimize the possibility of damage to optical coatings, or scratches to lens surfaces follow the cleaning procedure as described here precisely.

### Required tools

- Compressed air
- Clean micro fiber lens cleaning cloth (e.g. Toraysee® cloth(s))
- Clean cotton cloth
- Lens cleaner (e.g. ZEISS lens cleaner, Purosol™ or other water based lens cleaner products)

### How to clean the lens?

1. Blow off dust with clean compressed air (or pressurized air cans<sup>4</sup>).
2. Clean with lens cleaner together with a clean lens cleaning cloth to remove the dust and contamination. Use big wipes in one single direction.
  -  **Warning:** Do not wipe back and forwards across the lens surface as this tends to grind dirt into the coating.
3. Use a dry lens cleaning cloth to remove left liquid or stripes. Polish with small circles.
4. If there are still fingerprints on the surface, wipe them off with lens cleaner together with a clean lens cleaning cloth. Polish again with a dry one.



If smears occur when cleaning lenses, replace the cloth. Smears are the first indication of a dirty cloth.

4. Pressurized air cans are not efficient if there is too much dust on the surface, the pressure is too low



## 19.7 Cleaning the exterior of the projector

### How to clean the exterior of the projector ?

1. Switch off the projector and unplug the projector from the mains power net.
2. Clean the housing of the projector with a damp cloth. Stubborn stains may be removed with a cloth lightly dampened with a mild detergent solution.

## 19.8 Authorization to clear a security warning on the projector

### When is an authorization required to clear the security warning?

A media player security warning is triggered in the following cases:

- If a board is removed from or inserted into the card cage.
- If the link between ICP and IMB/IMS is removed.
- If the sealed compartment has been opened.

An authorization will be required to clear the security warning. Using the Web Communicator as a show manager, you can create an authorization pin code in case one of these security warnings is triggered.

### Required tools

- Authorization pin code
- Web Communicator

### Authorization procedure to clear security warning

1. Ensure that all modules and boards are properly installed.
2. Start up the projector (READY or ON mode).
3. Log onto the projector using Web Communicator.
4. In the notifications menu (both in Web Communicator or on the touch display), spot the error that can be cleared and press **Clear**.

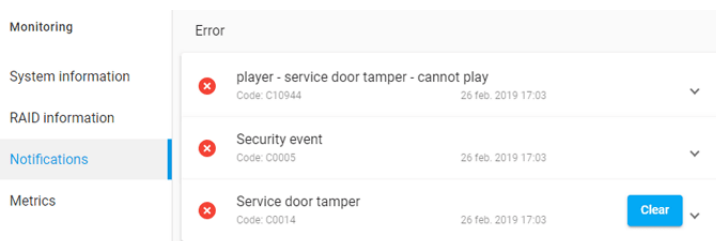

Image 19–6

A pop-up window will be prompted with input field and numeric display.

5. Enter the authorization pin code and confirm by pressing Start.

A pop-up window will be prompted with a countdown timer and instructions to press the key button within the time limit.



Image 19–7

6. Press the key button on the Cinema Controller (reference 1, [Image 19–8](#)).

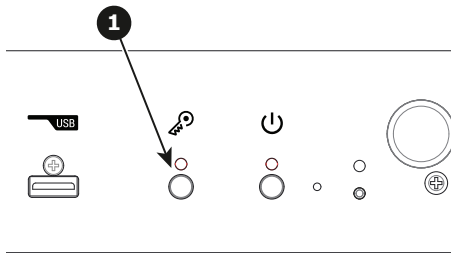

Image 19–8 Location of the key button



Each attempt to clear the security warning and its result (both successfully and unsuccessfully) is logged inside the projector.

# Removal and installation of projector covers without frame

# 20

20.1	Removal of the front cover.....	348
20.2	Removal of the rear cover .....	348
20.3	Mounting the rear cover .....	349
20.4	Mounting the front cover.....	350

## About this chapter

Most maintenance and service procedures demand removing one or more of the projector covers to gain access to the parts to maintain or to service. To avoid redundancy, all procedures about cover removing or installing are grouped together in this chapter. The maintenance and servicing procedures also refer to this chapter if required. The procedures in this chapter describe, with detailed step by step actions and illustrations, how to remove or install the projector covers for a projector without frame. Note that the covers may only be removed by qualified service personnel.

## 20.1 Removal of the front cover



If the front cover is the only cover you need to remove (e.g. when checking / replacing the filter), there is no need to turn off the projector.

### Required tools

No tools required.

### How to remove

1. Slide the front cover to the side of the Input & Communication Unit and remove it.



*Note:* The handles do not click open. They are fixed into the cover.

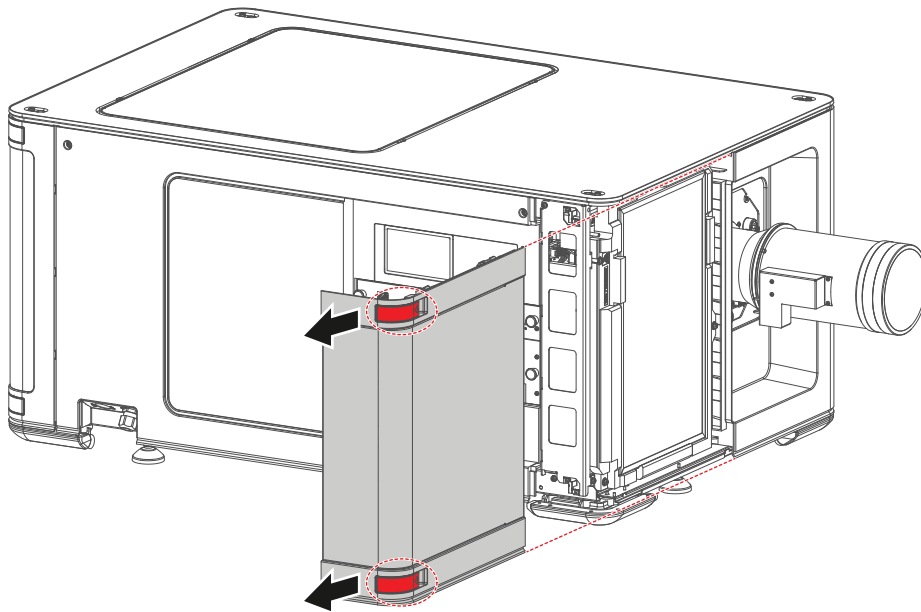

Image 20-1 Sliding the front cover away from the projector

## 20.2 Removal of the rear cover



If the rear cover is the only cover you need to remove (e.g. when checking / replacing the filter), there is no need to turn off the projector.

### Required tools

No tools required.

### How to remove

1. Slide the rear cover to the side of the Input & Communication unit and remove it.



*Note:* The handles do not click open. They are fixed into the cover.

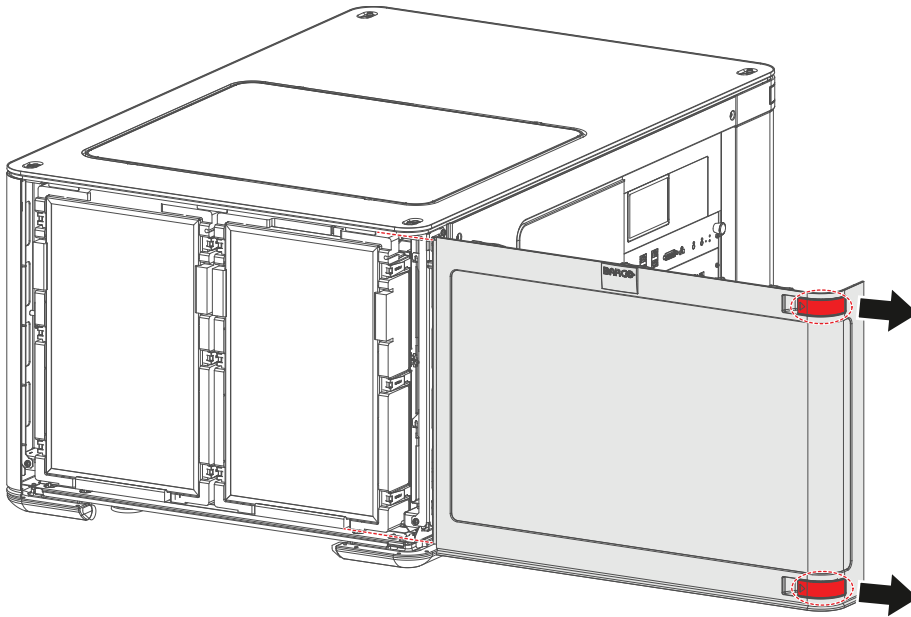

Image 20–2 Sliding the rear cover away from the projector

## 20.3 Mounting the rear cover

### Required tools

No tools required.

### How to mount

1. Place the cover over the cover hook on the bottom of the projector frame (reference 1).
2. Slide the clips in the rear cover over the cover hooks in the top of the frame (reference 2).

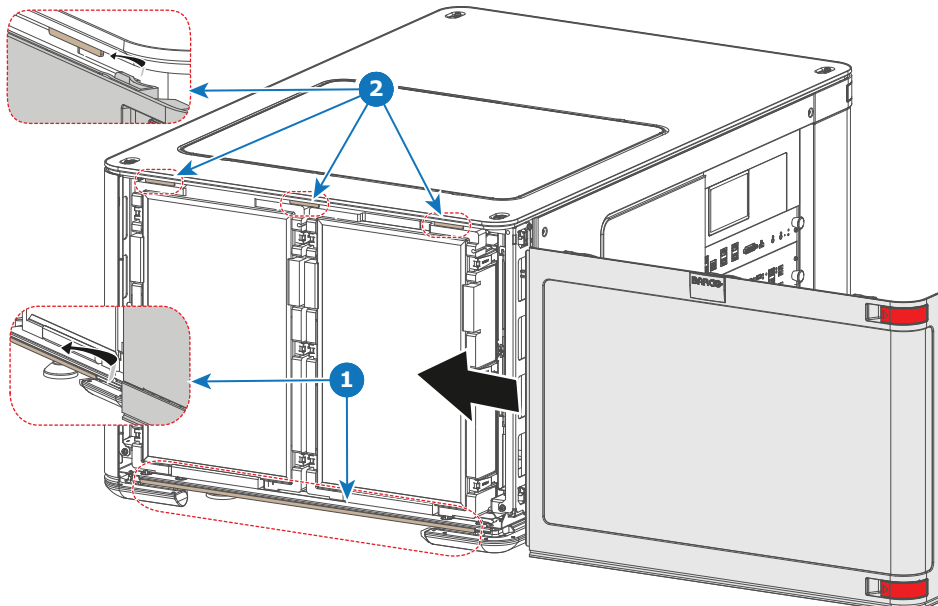

Image 20–3 Sliding in the rear cover

## 20.4 Mounting the front cover

### Required tools

No tools required.

### How to mount

1. Place the cover over the cover hook on the bottom of the projector frame (reference 1).
2. Slide the clips in the front cover over the cover hooks in the top of the frame (reference 2).

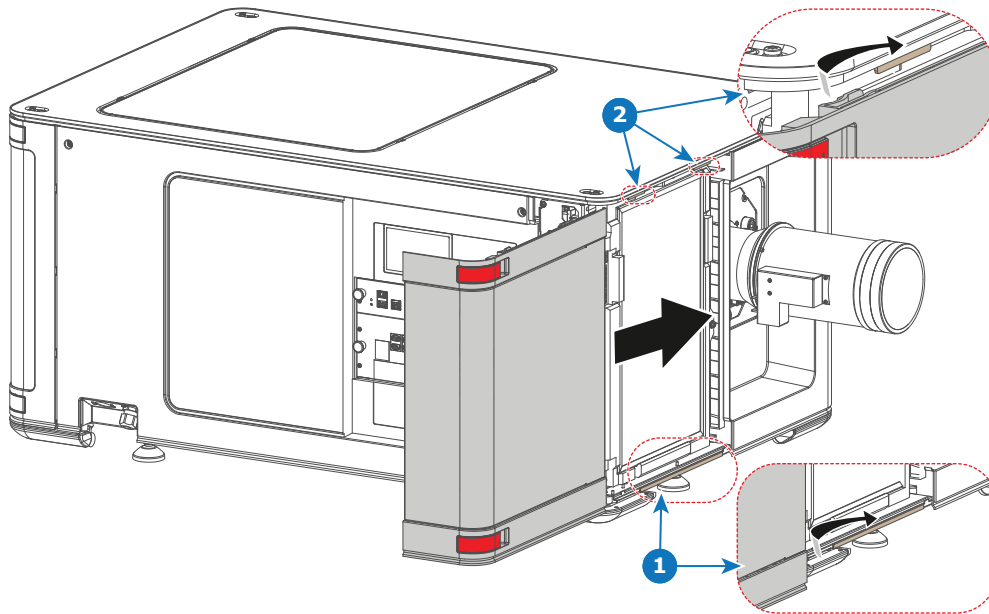

Image 20–4 Sliding in the front cover

# Removal and installation of projector covers with reinforcement frame

# 21

21.1	Removal of the front cover.....	352
21.2	Removal of the rear cover .....	352
21.3	Mounting the rear cover .....	353
21.4	Mounting the front cover.....	355

## About this chapter

Most maintenance and service procedures demand removing one or more of the projector covers to gain access to the parts to maintain or to service. To avoid redundancy, all procedures about cover removing or installing are grouped together in this chapter. The maintenance and servicing procedures also refer to this chapter if required. The procedures in this chapter describe, with detailed step by step actions and illustrations, how to remove or install the projector covers for a projector with reinforcement frame. Note that the covers may only be removed by qualified service personnel.

## 21.1 Removal of the front cover



If the front cover is the only cover you need to remove (e.g. when checking / replacing the filter), there is no need to turn off the projector.

### Required tools

Allen wrench 4 mm

### How to remove

1. Unlock the safety bracket on the side of the projector. Use a 4 mm Allen wrench to remove the hex screw locking the bracket (reference 1).

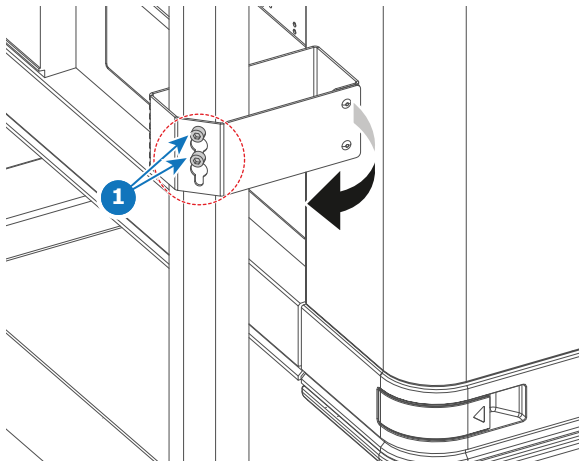

Image 21-1

2. Rotate and move the bracket to a position it won't hinder you while removing the front cover.
3. Slide the front cover to the side of the Input & Communication Unit towards the frame bar (reference 2) and remove it (reference 3).



*Note:* The handles do not click open. They are fixed into the cover.

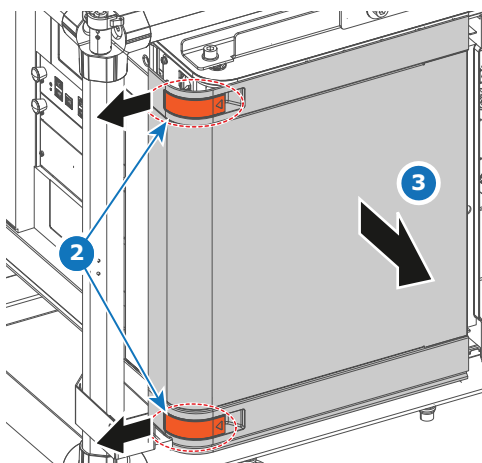

Image 21-2 Sliding the front cover towards the frame bar and removing it.

## 21.2 Removal of the rear cover



If the rear cover is the only cover you need to remove (e.g. when checking / replacing the filter), there is no need to turn off the projector.



## Required tools

Allen wrench 4 mm

## How to remove

1. Unlock the safety bracket on the side of the projector. Use a 4 mm Allen wrench to remove the hex screw locking the bracket (reference 1).

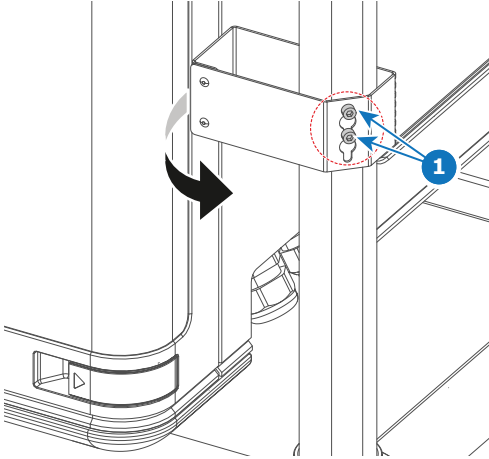



Image 21-3

2. Rotate and move the bracket to a position it won't hinder you while removing the rear cover.
3. Slide the rear cover towards the bar of the frame (reference 2) as much as possible.

 **Note:** The handles do not click open. They are fixed into the cover.

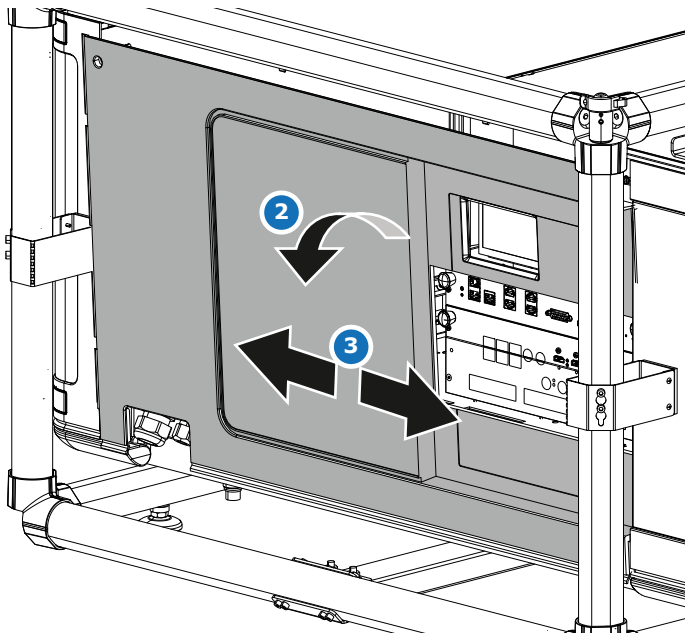

Image 21-4 Sliding the front cover towards the frame bar and removing it.

4. Tilt the rear cover a bit and remove it (reference 3).

## 21.3 Mounting the rear cover

### Required tools

Allen wrench 4 mm

## How to mount

1. Place the cover over the cover hook on the bottom of the projector frame (reference 1), while making sure it fits next to the frame bar.
2. Place the topside of the cover near the cover hooks on the top of the rear frame (reference 2).
3. Slide the clips in the rear cover over the cover hooks.

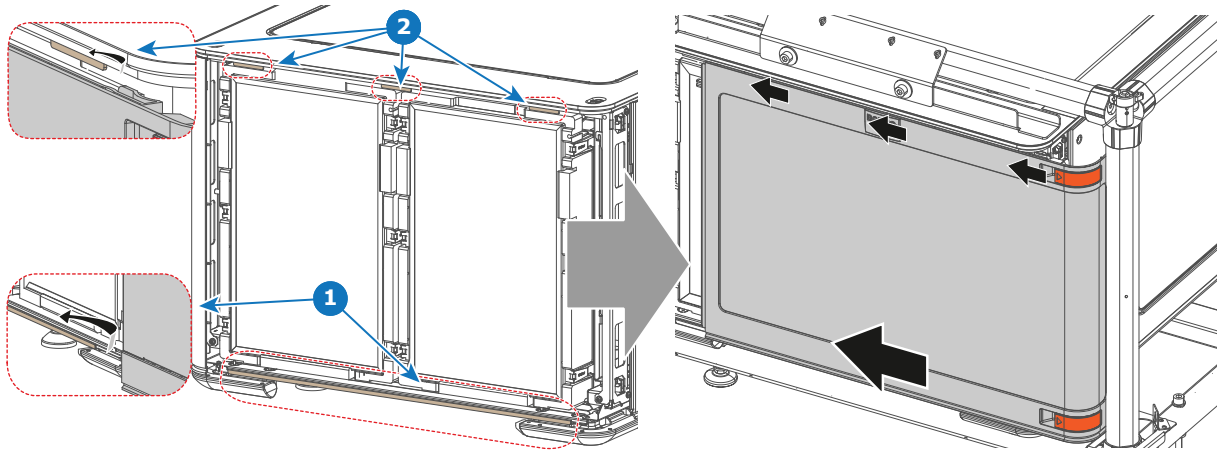

Image 21-5 Sliding in the rear cover

4. Move the locking bracket (reference 3) to the position of the holes in the frame bar (reference 4).

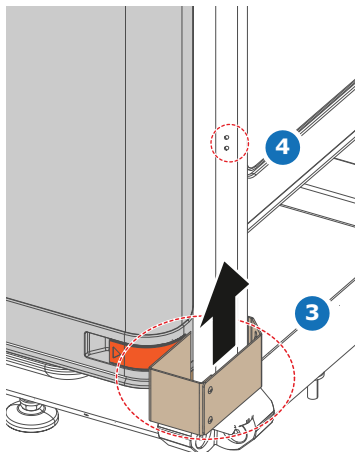

Image 21-6 Positioning the safety bracket

5. Lock the safety bracket in its place. Use a 4 mm Allen wrench to drive in the screw.

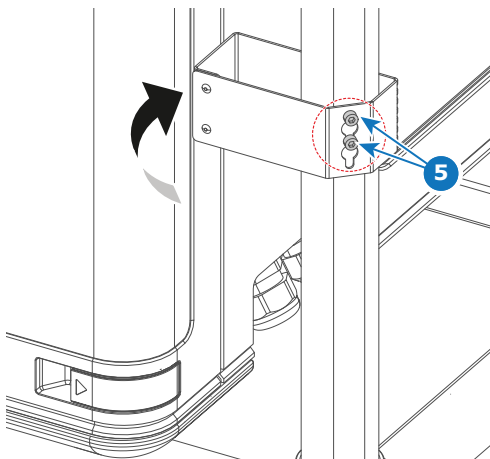

Image 21-7 Locking the safety bracket

## 21.4 Mounting the front cover

### Required tools

Allen wrench 4 mm

### How to mount

1. Place the cover over the longer cover hook on the bottom of the projector frame (reference 1).
2. Slide the clips in the front cover over the smaller cover hooks in the top of the frame (reference 2).

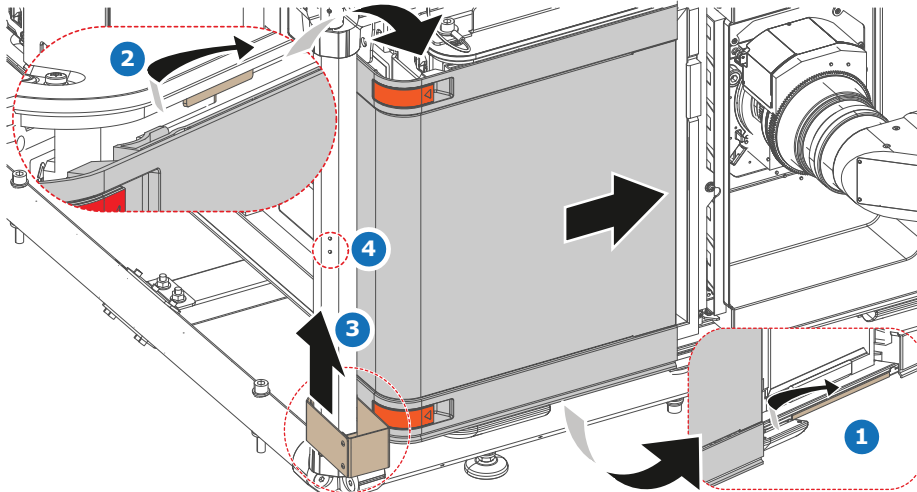

Image 21–8 Sliding in the front cover

3. Move the locking bracket (reference 3) to the position of the holes in the frame bar (reference 4)
4. Lock the safety bracket in place. Use a 4 mm Allen wrench to drive in the two screws.

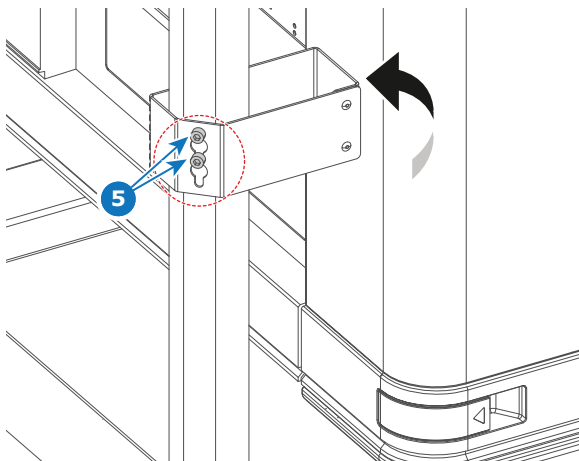

Image 21–9 Locking the safety bracket



# Specifications

# A

A.1	Specifications Freya .....	358
A.2	Specification Freya MKII .....	360
A.3	Specification Freya+ .....	362
A.4	Specifications of the ICMP-X .....	364
A.5	ICMP-X SDI specifications .....	365
A.6	ICMP-X HDMI 2.0 specifications .....	368

## A.1 Specifications Freya

### Specifications

<b>Projector type</b>	Three chip DLP
<b>Technology</b>	3x 0.98" DC4K TRP
<b>Resolution</b>	4,096 x 2,160 (4K)
<b>Aspect ratio</b>	1.89:1
<b>Light source</b>	RGB Laser
<b>Light output</b>	7,500 ANSI Lumens
<b>Contrast ratio</b>	2,400:1 Sequential 950:1 ANSI
<b>Brightness uniformity</b>	80% at Sides 75% at Corners
<b>Lens range</b>	<p><b>Type B Lenses:</b>  <b>(R98565252)</b> - Zoom Lens 1.38" HC 4K: 1.58 – 2.41:1  <b>(R98565262)</b> - Zoom Lens 1.38" HC 4K: 1.88 – 2.60:1  <b>(R98565272)</b> - Zoom Lens 1.38" HC 4K: 2.00 – 2.94:1  <b>(R98565282)</b> - Zoom Lens 1.38" HC 4K: 2.30 – 3.65:1  <b>(R98565292)</b> - Zoom Lens 1.38" HC 4K: 2.79 – 4.68:1</p> <p><b>Type C Lenses:</b>  <b>(R9801414)</b> - TLD+ ULTRA LENS: 0.80 - 1.16:1  <b>(R9862005)</b> - TLD+ ULTRA LENS: 1.09 - 1.40:1</p>
<b>Optical lens shift</b>	<p><b>Type B Lenses:</b>  56% Up and Down  29% Left and Right</p> <p><b>Type C Lenses:</b>  15% Up and 35% Down  7.5% Left and Right</p>
<b>Tilt</b>	15° Forwards 15° Backwards
<b>Color correction</b>	P7
<b>Color gamut</b>	DCI P3 (98.5% of Rec.2020; when measured in xy-color coordinates)
<b>Image processing</b>	Alchemy - Integrated Cinema Media Processor (ICMP)
<b>WARP</b>	N/A
<b>Orientation</b>	Pedestal / Table Top
<b>Network connection</b>	10/100 Ethernet via RJ45 connection
<b>HDR</b>	HDR10
<b>3D</b>	Active glasses systems and polarization systems on silver screens are supported. Color separation systems are not supported.
<b>Inputs</b>	Barco Alchemy ICMP included in the projector: 2 x HDMI2.0a (up to 4K 2D 60fps) 2 x 3G-SDI inputs

	16 x AES/EBU audio channels (2 x RJ45) 8 x GPI, 8 x GPO (4 x RJ45) 2 x Gbe for content connectivity & ingest 2 x front-accessible USB 3.0 for fast ingest 2 x front-accessible USB 2.0 DCI 4K 2D up to 60fps* DCI 4K 3D (24 or 30fps per eye)* DCI High Frame Rates 2K 3D up to 120fps (60fps per eye) JPEG 2000 bit-rates up to 625 Mbps MPEG-2 (4:2:0 and 4:2:2 up to 60fps)
<b>DCI</b>	DCI Compliant
<b>Integrated storage</b>	3.9TB effective storage (RAID-5) via 3 x 2TB Hot-swappable 2.5" hard-drives
<b>Control</b>	RS232, TCP/IP, 8 x GPIO
<b>Power requirements</b>	Single Phase: 200 - 240V, L1 + N + PE, 9A, 50 - 60Hz (Y) Triple Phase: 200 - 240 / 346 - 415V, 3W + N + PE, 8A, 50/60Hz Triple Phase: 200 - 240, 3W + PE, 8A, 50/60Hz
<b>Power consumption</b>	1.4kW (3W in Eco Mode)
<b>Noise level (typical at 25°C/ 77°F)</b>	48 dB(A) - Min (ambient temperature below 20°C) 50 dB(A) - Normal 60 dB(A) - Max (ambient temperature over 35°C)
<b>Operating temperature</b>	10 - 40°C (104F) Max. (at Sea Level)
<b>Operating humidity</b>	20 - 80% Relative Humidity
<b>BTU per hour</b>	4,600 BTU/h
<b>Airflow requirements</b>	Air Inlet (from Rear w/Feet Down): Front / Rear / Bottom (at user input side) Exhaust (from Rear w/Feet Down): Top
<b>Exhaust airflow</b>	300 CFM
<b>Dimensions (WxLxH)</b>	Excluding Lens <b>C Type Lens Holder:</b> 710 x 1,070 x 547 mm 27.95 x 42.13 x 21.54 inches <b>B Type Lens Holder:</b> 710 x 1,132 x 547 mm 27.95 x 44.55 x 21.54 inches
<b>Weight</b>	Excluding Lens 90kg / 198.5lbs
<b>Warranty</b>	Limited 3 years parts and labor Extendable up to 5 years
<b>Safety requirements</b>	Class 1 - Risk Group 3

## A.2 Specification Freya MKII

### Specifications

<b>Projector type</b>	Three chip DLP
<b>Technology</b>	3x 0.98" DC4K TRP
<b>Resolution</b>	4,096 x 2,160 (4K)
<b>Aspect ratio</b>	1.89:1
<b>Light source</b>	RGB Laser
<b>Light output</b>	7,500 ANSI Lumens
<b>Contrast ratio</b>	5,500:1 Sequential 1,000:1 ANSI
<b>Brightness uniformity</b>	80% at Sides 75% at Corners
<b>Lens range</b>	<b>Type B Lenses:</b> <b>(R98565253)</b> - Zoom Lens 1.38" VHC 4K: 1.58 – 2.41:1 <b>(R98565263)</b> - Zoom Lens 1.38" VHC 4K: 1.89 – 2.60:1 <b>(R98565273)</b> - Zoom Lens 1.38" VHC 4K: 2.00 – 2.94:1 <b>(R98565283)</b> - Zoom Lens 1.38" VHC 4K: 2.30 – 3.65:1 <b>(R98565293)</b> - Zoom Lens 1.38" VHC 4K: 2.80 – 4.69:1 <b>Type C Lenses:</b> <b>(R98620053)</b> - TLD+ VHC ULTRA LENS: 1.09 - 1.40:1 <b>(R98620103)</b> - TLD+ VHC ULTRA LENS: 1.28 - 1.74:1
<b>Optical lens shift</b>	<b>Type B Lenses:</b> 55% Up and Down 30% Left and Right <b>Type C Lenses:</b> 21% Up and 50% Down 10% Left and Right
<b>Tilt</b>	<b>Freya:</b> 15° Forwards 15° Backwards <b>Freya Arcitechural:</b> 90° Forwards 90° Backwards
<b>Color correction</b>	P7
<b>Color gamut</b>	DCI P3 (98.5% of Rec.2020; when measured in xy-color coordinates)
<b>Image processing</b>	Alchemy - Integrated Cinema Media Processor (ICMP)
<b>WARP</b>	N/A
<b>Orientation</b>	Pedestal / Table Top
<b>Network connection</b>	10/100 Ethernet via RJ45 connection
<b>HDR</b>	HDR10
<b>3D</b>	Active glasses systems and polarization systems on silver screens are supported.



	Color separation systems are not supported.
<b>Inputs</b>	Barco Alchemy ICMP included in the projector: 2 x HDMI2.0a (up to 4K 2D 60fps) 2 x 3G-SDI inputs 16 x AES/EBU audio channels (2 x RJ45) 8 x GPI, 8 x GPO (4 x RJ45) 2 x Gbe for content connectivity & ingest 2 x front-accessible USB 3.0 for fast ingest 2 x front-accessible USB 2.0 DCI 4K 2D up to 60fps* DCI 4K 3D (24 or 30fps per eye)* DCI High Frame Rates 2K 3D up to 120fps (60fps per eye) JPEG 2000 bit-rates up to 625 Mbps MPEG-2 (4:2:0 and 4:2:2 up to 60fps)
<b>DCI</b>	DCI Compliant
<b>Integrated storage</b>	3.9TB effective storage (RAID-5) via 3 x 2TB Hot-swappable 2.5" hard-drives
<b>Control</b>	RS232, TCP/IP, 8 x GPIO
<b>Power requirements</b>	Single Phase: 200 - 240V, L1 + N + PE, 9A, 50 - 60Hz (Y) Triple Phase: 200 - 240 / 346 - 415V, 3W + N + PE, 8A, 50/60Hz Triple Phase: 200 - 240, 3W + PE, 8A, 50/60Hz
<b>Power consumption</b>	1.4kW (3W in Eco Mode)
<b>Noise level (typical at 25°C/ 77°F)</b>	48 dB(A) - Min (ambient temperature below 20°C) 50 dB(A) - Normal 60 dB(A) - Max (ambient temperature over 35°C)
<b>Operating temperature</b>	10 - 40°C (104F) Max. (at Sea Level)
<b>Operating humidity</b>	20 - 80% Relative Humidity
<b>BTU per hour</b>	4,600 BTU/h
<b>Airflow requirements</b>	Air Inlet (from Rear w/Feet Down): Front / Rear / Bottom (at user input side) Exhaust (from Rear w/Feet Down): Top
<b>Exhaust airflow</b>	300 CFM
<b>Dimensions (WxLxH)</b>	<b>Freya: (excl. Lens)</b> <b>C Type Lens Holder:</b> 710 x 1,070 x 547 mm 27.95 x 42.13 x 21.54 inches <b>B Type Lens Holder:</b> 710 x 1,132 x 547 mm 27.95 x 44.55 x 21.54 inches <b>Freya Arcitechural: (excl. Lens)</b> <b>C Type Lens Holder:</b> TBC x TBC x TBC mm TBC x TBC x TBC inches <b>B Type Lens Holder:</b> TBC x TBC x TBC mm

	TBC x TBC x TBC inches
<b>Weight</b>	<b>Freya: (excl. Lens)</b> 90kg / 198.5lbs <b>Freya Arcitechural: (excl. Lens)</b> TBC kg / TBC lbs
<b>Warranty</b>	Limited 3 years parts and labor Extendable up to 5 years
<b>Safety requirements</b>	Class 1 - Risk Group 3

## A.3 Specification Freya+

### Specifications

<b>Projector type</b>	Three chip DLP
<b>Technology</b>	3x 0.98" DC4K TRP
<b>Resolution</b>	4,096 x 2,160 (4K)
<b>Aspect ratio</b>	1.89:1
<b>Light source</b>	RGB Laser
<b>Light output</b>	13,500 ANSI Lumens
<b>Contrast ratio</b>	5,500:1 Sequential 1,000:1 ANSI
<b>Brightness uniformity</b>	80% at Sides 75% at Corners
<b>Lens range</b>	<b>Type B Lenses:</b> (R98565253) - Zoom Lens 1.38" VHC 4K: 1.58 – 2.41:1 (R98565263) - Zoom Lens 1.38" VHC 4K: 1.89 – 2.60:1 (R98565273) - Zoom Lens 1.38" VHC 4K: 2.00 – 2.94:1 (R98565283) - Zoom Lens 1.38" VHC 4K: 2.30 – 3.65:1 (R98565293) - Zoom Lens 1.38" VHC 4K: 2.80 – 4.69:1 <b>Type C Lenses:</b> (R98620053) - TLD+ VHC ULTRA LENS: 1.09 - 1.40:1 (R98620103) - TLD+ VHC ULTRA LENS: 1.28 - 1.74:1
<b>Optical lens shift</b>	<b>Type B Lenses:</b> 55% Up and Down 30% Left and Right <b>Type C Lenses:</b> 21% Up and 50% Down 10% Left and Right
<b>Tilt</b>	<b>Freya+:</b> 15° Forwards 15° Backwards <b>Freya+ Arcitechural:</b> 90° Forwards 90° Backwards

<b>Color correction</b>	P7
<b>Color gamut</b>	DCI P3 (98.5% of Rec.2020; when measured in xy-color coordinates)
<b>Image processing</b>	Alchemy - Integrated Cinema Media Processor (ICMP)
<b>WARP</b>	N/A
<b>Orientation</b>	Pedestal / Table Top
<b>Network connection</b>	10/100 Ethernet via RJ45 connection
<b>HDR</b>	HDR10
<b>3D</b>	Active glasses systems and polarization systems on silver screens are supported. Color separation systems are not supported.
<b>Inputs</b>	Barco Alchemy ICMP included in the projector: 2 x HDMI2.0a (up to 4K 2D 60fps) 2 x 3G-SDI inputs 16 x AES/EBU audio channels (2 x RJ45) 8 x GPI, 8 x GPO (4 x RJ45) 2 x Gbe for content connectivity & ingest 2 x front-accessible USB 3.0 for fast ingest 2 x front-accessible USB 2.0 DCI 4K 2D up to 60fps* DCI 4K 3D (24 or 30fps per eye)* DCI High Frame Rates 2K 3D up to 120fps (60fps per eye) JPEG 2000 bit-rates up to 625 Mbps MPEG-2 (4:2:0 and 4:2:2 up to 60fps)
<b>DCI</b>	DCI Compliant
<b>Integrated storage</b>	3.9TB effective storage (RAID-5) via 3 x 2TB Hot-swappable 2.5" hard-drives
<b>Control</b>	RS232, TCP/IP, 8 x GPIO
<b>Power requirements</b>	Single Phase: 200 - 240V, L1 + N + PE, 9A, 50 - 60Hz (Y) Triple Phase: 200 - 240 / 346 - 415V, 3W + N + PE, 8A, 50/60Hz Triple Phase: 200 - 240, 3W + PE, 8A, 50/60Hz
<b>Power consumption</b>	1.4kW (3W in Eco Mode)
<b>Noise level (typical at 25°C/ 77°F)</b>	48 dB(A) - Min (ambient temperature below 20°C) 50 dB(A) - Normal 60 dB(A) - Max (ambient temperature over 35°C)
<b>Operating temperature</b>	10 - 40°C (104F) Max. (at Sea Level)
<b>Operating humidity</b>	20 - 80% Relative Humidity
<b>BTU per hour</b>	4,600 BTU/h
<b>Airflow requirements</b>	Air Inlet (from Rear w/Feet Down): Front / Rear / Bottom (at user input side) Exhaust (from Rear w/Feet Down): Top
<b>Exhaust airflow</b>	300 CFM
<b>Dimensions (WxLxH)</b>	<b>Freya+: (excl. Lens)</b> <b>C Type Lens Holder:</b>

	<p>710 x 1,070 x 547 mm 27.95 x 42.13 x 21.54 inches</p> <p><b>B Type Lens Holder:</b> 710 x 1,132 x 547 mm 27.95 x 44.55 x 21.54 inches</p> <p><b>Freya+ Arcitechural: (excl. Lens)</b></p> <p><b>C Type Lens Holder:</b> TBC x TBC x TBC mm TBC x TBC x TBC inches</p> <p><b>B Type Lens Holder:</b> TBC x TBC x TBC mm TBC x TBC x TBC inches</p>
<b>Weight</b>	<p><b>Freya+: (excl. Lens)</b> 90kg / 198.5lbs</p> <p><b>Freya Arcitechural+: (excl. Lens)</b> TBC kg / TBC lbs</p>
<b>Warranty</b>	<p>Limited 3 years parts and labor Extendable up to 5 years</p>
<b>Safety requirements</b>	<p>Class 1 - Risk Group 3</p>

## A.4 Specifications of the ICMP-X

### Specifications

<b>Integrated Cinema Media Processor</b>	<p>DCI 4K 2D up to 60fps DCI 4K 3D (24 or 30 fps per eye) DCI High Frame Rates 2K 3D up to 120fps (60fps per eye) JPEG 2000 bit-rates up to 625Mbps Dual-channel color-correction MPEG-2 (4:2:0 and 4:2:2 up to 60fps) 2x HDMI2.0a (up to 4K 2D 60fps) 2x 3G-SDI inputs 16x AES/EBU audio channels (2x RJ45) 8x GPI, 8x GPO (4x RJ45) 2x Gbe for content connectivity &amp; ingest 2x front-accessible USB 3.0 for fast ingest 2x front-accessible USB 2.0 Video and audio watermarking: Civolution NexGuard Closed captioning devices: Support for SMPTE 430-10 Streaming of Live IP content</p>
<b>Barco Web Commander</b>	<p>Projector dashboard Projector control board Show player/editor/scheduler Automation, 3D, Ingest Smart projector status Via HTML5 web browsers including iOS &amp; Android tablets Compatible with free Barco CineMate iOS &amp; Android app</p>

<b>Barco Commander (for touch panel controller)</b>	Projector control board Show Player/Editor/Scheduler Automation, 3D, ingest Dynamic DCP playlists & intermission Smart projector status
<b>Barco (Web) Communicator</b>	Projector installation & configuration Projector update & maintenance Barco CineMate App (iOS & Android) - free
<b>Integrated storage</b>	2TB effective storage (RAID-5) / 3x 1TB Hot-swappable 2.5" hard-drives 4TB effective storage (RAID-5) / 3x 2TB Hot-swappable 2.5" hard-drives 8TB effective storage (RAID-5) / 3x 4TB Hot-swappable 2.5" solid state drives
<b>Options</b>	ICMP License for HDMI2.0 HDR ICMP License for Live IP
<b>Compatibility</b>	Barco Alchemy is supported by the following Theater Management System (TMS) brands: AAM Screenwriter, Ymagis Melody, CFG-Barco, Unique RosettaBridge, ADDE, CinéDigital Manager, GDC, Proyecson, Real Image, Sony, Hollywoodsoftware/Comscore TCC, Kinoton Barco Alchemy is supported by 4DX Experience

## A.5 ICMP-X SDI specifications

### 3G-SDI



Serial Digital Interface (SDI) is a serial link standardized by ITU-R BT.656 and the Society of Motion Picture and Television Engineers (SMPTE). SDI transmits uncompressed digital video over 75-ohm coaxial cable within studios, and is seen on most professional video infrastructure equipment. The first revision of the standard, SMPTE 259M, was defined to carry digital representation of analog video such as NTSC and PAL over a serial interface and is more popularly known as standard-definition (SD) SDI. The data rate required to transmit SD SDI is 270 Mbps. With the advent of high-definition (HD) video standards such as 1080i and 720p, the interface was scaled to handle higher data rates of 1.485 Gbps. The 1.485-Gbps serial interface is commonly called the HD SDI interface and is defined by SMPTE 292M, using the same 75-ohm coaxial cable. Studios and other video production facilities have invested heavily on the hardware infrastructure for coaxial cable and have a vested interest in extending the life of their infrastructure. Fortunately, SMPTE recently ratified a new standard called SMPTE 424M that doubles the SDI data rates to 2.97 Gbps using the same 75-ohm coaxial cable. This new standard, also called 3-Gbps (3G)-SDI, enables higher resolution of picture quality required for 1080p and digital cinema.

### SDI terminology

#### Standard HD-SDI signal (Single Link)

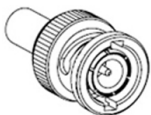

1.5Gb/s



HD 4:2:2

Standard HD-SDI allows for a single 4:2:2 image to be carried on one cable at 1.485 Gb/s. The image uses the Y Cb Cr colorspace and uses a bit depth of 10 bit per color component.

Due to the data rate limitations only 23.976, 24, 25, 29.970 and 30 fps streams are achievable.

### Dual-Link HD-SDI signal

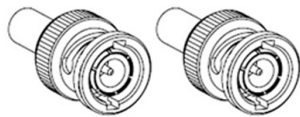

1.5Gb/s



1080p 50/60<sup>5</sup>  
or  
1080p 4:4:4

Dual-Link HD-SDI is mainly two standard HD-SDI signals carrying a single image stream split between the two cables. The main advantage is that color subsampling is no longer required, and the image can be transmitted in 4:4:4 quality, which then also allows the RGB (or XYZ) color space to be used.

The main link will contain a standard HD-SDI signal, the second (enhancement) link contains the missing Cb and Cr samples.

Depending on the implementation the enhancement link could also contain extra information to increase the bit depth.

### 3G HD-SDI signal

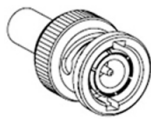

3Gb/s



1080p 50/60 (Level A)  
or  
1080p 4:4:4 (Level B)

3G HD-SDI uses a higher data rate (2.97 Gb/s). This allows a single cable interface to achieve the same capabilities of a Dual-Link HD-SDI implementation.

In direct mapping (level A) this is used to achieve higher frame rates. (50, 59.940 and 60 fps streams are supported).

### Dual Stream 3G HD-SDI signal

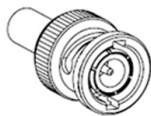

3Gb/s



HD 4:2:2 Signal #1  
and  
HD 4:2:2 Signal #2

Dual Stream 3G is a specific variant of the 3G signal which combines two completely separate 4:2:2 image streams into a single 3G signal. This can be used to transmit stereoscopic streams by keeping the left and right eye signals together.

## SMPTE 292M STANDARD 1.485 Gb/s HD-SDI SIGNALS

### Standard HD-SDI (SMPTE 292M) formats

SMPTE Standard	Source Resolution	Frame Rate	Display Rate	Scan Type
SMPTE 296M	1280 x 720	23.976	23.976	Progressive Y Cb Cr 4:2:2 10-Bit
		24	24	
		25	25	
		29.970	29.970	
		30	30	
		50	50	
		59.940	59.940	
SMPTE 274M SMPTE 428-8	1920 x 1080 2048 x 1080	23.976	23.976	Progressive Y Cb Cr 4:2:2 10-Bit
		24	24	
		25	25	
		29.97	29.97	
		30	30	

5. Not supported in Alchemy

<b>SMPTE Standard</b>	<b>Source Resolution</b>	<b>Frame Rate</b>	<b>Display Rate</b>	<b>Scan Type</b>
SMPTE 274M SMPTE 428-9 (SMPTE RP211)	1920 x 1080 2048 x 1080	23.976 24 25 29.97 30	23.976 24 25 29.97 30	Segmented frame Y Cb Cr 4:2:2 10-Bit
SMPTE 274M	1920 x 1080	25 29.970 30	50 59.940 60	Interlaced Y Cb Cr 4:2:2 10-Bit

**Dual-Link HD-SDI (SMPTE 372M) formats**

<b>SMPTE Standard</b>	<b>Source Resolution</b>	<b>Frame Rate</b>	<b>Display Rate</b>	<b>Scan Type</b>
SMPTE 274M SMPTE 428-8	1920 x 1080 2048 x 1080	23.976 24 25 29.970 30	23.976 24 25 29.970 30	Progressive Y Cb Cr 4:2:2 12-Bit only Y Cb Cr 4:4:4 10 or 12-Bit RGB (XYZ) 4:4:4 10 or 12-Bit
SMPTE 274M SMPTE 428-9 (SMPTE RP211)	1920 x 1080 2048 x 1080	23.976 24 25 29.970 30	23.976 24 25 29.970 30	Segmented frame Y Cb Cr 4:2:2 12-Bit only Y Cb Cr 4:4:4 10 or 12-Bit RGB (XYZ) 4:4:4 10 or 12-Bit
SMPTE 274M	1920 x 1080	25 29.970 30	50 59.940 60	Interlaced Y Cb Cr 4:2:2 12-Bit only Y Cb Cr 4:4:4 10 or 12-Bit RGB (XYZ) 4:4:4 10 or 12-Bit

**Standard HD-SDI (2 × SMPTE 292M) formats<sup>6</sup>**

<b>SMPTE Standard</b>	<b>Source Resolution</b>	<b>Frame Rate</b>	<b>Display Rate</b>	<b>Scan Type</b>
SMPTE 292M SMPTE 428-8	1920 x 1080 2048 x 1080	23.976 24 25 29.97 30	47.952 48 50 59.940 60	Progressive Y Cb Cr 4:2:2 10-Bit
SMPTE 292M SMPTE 428-9 (SMPTE RP211)	1920 x 1080 2048 x 1080	23.976 24 25 29.97 30	47.952 48 50 59.940 60	Segmented frame Y Cb Cr 4:2:2 10-Bit

The standard HD-SDI interfaces support the Y Cb Cr colorspace (both legal and full range) using 4:2:2 color subsampling.

The Dual-Link HD-SDI interface can be used to carry a single 4:4:4 image, having a color depth of 10 or 12 bit per component. Both RGB (XYZ) and Y Cb Cr color spaces are supported.

6. mainly used to carry stereoscopic images.

## SMPTE 424M 3G HD-SDI 2.970 Gb/s SIGNALS

### 3G HD-SDI (SMPTE 425) formats

SMPTE Standard	Source Resolution	Frame Rate	Display Rate	Scan Type
SMPTE 296M	1280 x 720	23.976	23.976	Progressive Y Cb Cr 4:4:4 10-Bit RGB (XYZ) 4:4:4 10-Bit
		24	24	
		25	25	
		29.970	29.970	
		30	30	
		50	50	
		59.940	59.940	
SMPTE 274M <sup>7</sup>	1920 x 1080	50	50	Progressive Y Cb Cr 4:2:2 10-Bit
		59.940	59.940	
		60	60	
SMPTE 274M	1920 x 1080	23.976	23.976	Progressive Y Cb Cr 4:2:2 12-Bit only Y Cb Cr 4:4:4 10 or 12-Bit RGB (XYZ) 4:4:4 10 or 12-Bit
		24	24	
		25	25	
		29.97	29.97	
SMPTE 274M	1920 x 1080	50	50	Interlaced Y Cb Cr 4:2:2 12-Bit only Y Cb Cr 4:4:4 10 or 12-Bit RGB (XYZ) 4:4:4 10 or 12-Bit
		59.940	59.940	
		60	60	
SMPTE 428-9	2048 x 1080	23.976	23.976	Progressive Y Cb Cr 4:4:4 12-Bit RGB (XYZ) 4:4:4 12-Bit
		24	24	

### Dual Stream 3G HD-SDI (SMPTE 425) formats

SMPTE Standard	Source Resolution	Frame Rate	Display Rate	Scan Type
SMPTE 292M SMPTE 428-9	1920 x 1080 2048 x 1080	23.976	47.952	Progressive Y Cb Cr 4:2:2 10-Bit
		24	48	
		25	50	
		29.970	59.940	
		30	60	

## A.6 ICMP-X HDMI 2.0 specifications

### HDMI



HDMI (High-Definition Multimedia Interface) is a compact audio/video interface for transferring uncompressed video data and compressed/uncompressed digital audio data from a HDMI-compliant device ("the source device") to a compatible computer monitor, video projector, digital television, or digital audio device. HDMI is a digital replacement for existing analog video standards.

### HDMI 2.0 specifications

#### HDMI

7. only supported in 3G level A mapping, others formats are supported in both level A and level B mapping.



Both HDMI 2.0 inputs are fully compliant with the HDMI 1.4, 1.4a, 1.4b, 2.0 and 2.0a revisions of the HDMI specification.

Full Range and Limited Range Quantization are supported for all specified formats.

BT.709 and DCI-P3 are supported for all formats. For HDR content (UHD and 4K only) the BT.2020 color coding is supported.

All video streams should have a progressive scan order, with the exception of 1920x1080i 60 fps (interlaced scan).

#### HDCP

Both HDMI 2.0 inputs are HDCP 1.4 & HDCP 2.2 compliant.

#### HDR (SMPTE ST 2084)

HDR (High Dynamic Range) is supported on all UHD and 4K formats.

This includes SMPTE ST 2084 (static metadata) and BT.2020 color coding. Requires a license!

### HDMI 2.0 Cable requirements

All HDMI cables should work with HDMI 2.0 receivers. There is no such thing as a “4K HDMI cable” even though this is sometimes sold this way. But of course there are quality differences. The “high-speed” cables would be preferred over the “standard-speed” cables. They usually work at higher cable lengths than the standard-speed ones.



The “Premium Certified HDMI” cables are tested to work with high bandwidth as is the case with 4K HDR content. These can be more expensive though. When using active and/or optical cables you should verify if the integrated receiver and sender are HDMI certified to guarantee to work compliant with the HDMI protocol. You can request the HDMI certificate to the manufacturer of the cable.



The ICMP is not supporting Ethernet-over-HDMI and such specific cables are thus not required.

### HDMI 2.0 Supported 2D Formats

Format	Frame Rate	Color coding	Bit depth
1280x720	23.976	RGB	8
	24	YCbCr 4:4:4	10
	25	YCbCr 4:2:2	12
	29.97		
	30		
	50		
	59.94		
1280x720	60		
	100	RGB	8
	119.88	YCbCr 4:4:4	
1920x1080 2048x1080	120	YCbCr 4:2:2	
	23.976	RGB	8
	24	YCbCr 4:4:4	10
	25	YCbCr 4:2:2	12
	29.97		

Format	Frame Rate	Color coding	Bit depth
	30 50 59.94 60		
1920x1080 2048x1080	100 119.88 120	RGB YCbCr 4:4:4 YCbCr 4:2:2	8
3840x2160 4096x2160	23.976 24 25 29.97 30	RGB YCbCr 4:4:4 YCbCr 4:2:2	8 10 12
3840x2160 4096x2160	50 59.94 60	RGB YCbCr 4:4:4 YCbCr 4:2:2	8

### HDMI 2.0 Supported 3D (Frame Packing) Formats

Format	Frame Rate	Color coding	Bit depth
1920x1080 2048x1080	23.976 24 25 29.97 30	RGB YCbCr 4:4:4 YCbCr 4:2:2	8 10 12
1920x1080 2048x1080	50 59.94 60	RGB YCbCr 4:4:4 YCbCr 4:2:2	8
3840x2160 4096x2160	23.976 24 25 29.97, 30	RGB YCbCr 4:4:4 YCbCr 4:2:2	8 10 12
3840x2160 4096x2160	50 59.94 60	RGB YCbCr 4:4:4 YCbCr 4:2:2	8

### HDMI 2.0 Supported Audio Formats

Format	Sample Rate	Sample coding	Bit depth
2.0	32	L-PCM	16
2.1	44.1		20
5.1	48		24
7.1	88.2 96		

### HDMI 2.0 Supported Dual (Twin) Link Formats (2D formats only)

Format	Frame Rate	Color coding	Bit depth
1920x1080 2048x1080	23.976 24 25 29.97 30 50 59.94 60	RGB YCbCr 4:4:4 YCbCr 4:2:2	8
3840x2160 4096x2160	23.976 24 25 29.97 30 50 59.94 60	RGB YCbCr 4:4:4 YCbCr 4:2:2	8



Both HDMI2 inputs (port A & port B) should have to same Format, Frame Rate and Color coding.



Port A should contain the 8 most significant bits of the pixel data, where port B should contain the 8 least significant bits of the pixel data. The pixel data will be reconstructed using the all 8 bits of port A and using the 4 most significant bits of port B.

### HDMI 2.0 Supported Passive 3D Formats (3D formats only)

Format	Frame Rate	Color coding	Bit depth
1920x1080 2048x1080	24 30	RGB YCbCr 4:4:4 YCbCr 4:2:2	8 10 12
1920x1080 2048x1080	60	RGB YCbCr 4:4:4 YCbCr 4:2:2	8
3840x2160 4096x2160	24 30	RGB YCbCr 4:4:4 YCbCr 4:2:2	8



In Passive 3D HDMI2 input port A should contain the pixel data of Left Eye and HDMI2 input port B should contain the pixel data for Right Eye.



# Pin configurations

# B

B.1	About General Purpose Inputs & Outputs (GPIO).....	374
B.2	Pin configurations of the communication ports .....	375
B.3	Pin configurations of the ICMP-X communication ports.....	378
B.4	Pin configurations of the inputs .....	380

## B.1 About General Purpose Inputs & Outputs (GPIO)



The Barco Cinema Controller and the Barco ICMP-X are equipped with GPIO ports. The electrical specifications described in this chapter are the same for both GPIO ports.

### General Purpose inputs

The Barco Cinema Controller and the Barco ICMP-X have each eight (8) opto-isolated general purpose inputs available. These inputs are used to trigger the execution of macro files. For more explanation about the association of a macro to a GPI, consult the user guide of the Communicator.

### Input voltage

The inputs can be directly driven from a TTL or CMOS output.

- The shape of the pulse must be rectangular.
- The duration of the pulse must be at least 50 milliseconds (shorter pulses are considered as a switch bounce)
- Minimum voltage :  $V_{\min} = +5 \text{ V}$
- Maximum voltage Cinema Controller:  $V_{\max} = +24 \text{ VDC}$
- Maximum voltage ICMP-X=  $+18 \text{ VDC}$

### External power supply

When interfacing with contact closure outputs, an external power supply needs to be provided. Depending upon the configuration a suitable pull-up resistor needs to be added as well.

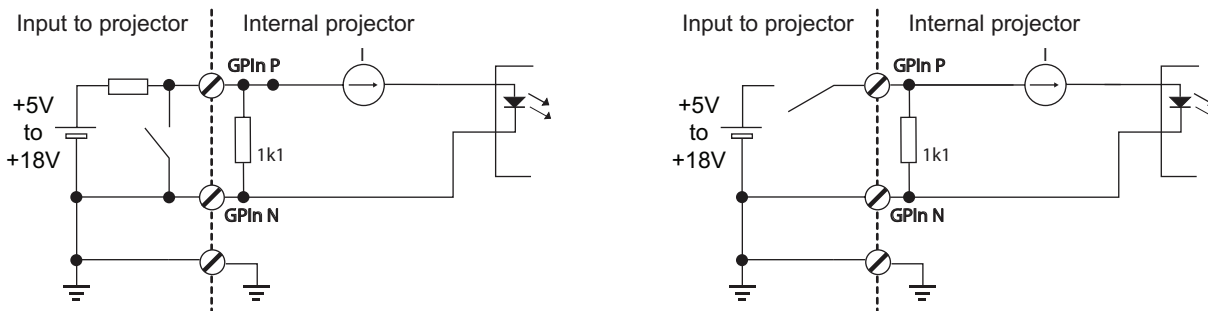

Image B-1

### Cables

When long cable connections are required the use of shielded cables with twisted pairs is recommended. One twisted pair is to be assigned to each GP Input pair.

### How to make the connection

When the power supply used to provide the DC voltage is isolated from ground (for example in the case of an AC adapter) it is recommended that the minus pole of that power supply is connected to ground (or to the projector chassis). This will avoid high common mode voltages at the projector GP Inputs. If that same power supply is used for other parts of the system, take care not to create ground loops. In any case when shielded cables are used that shield should be connected to the projector chassis.

### General Purpose outputs

The Barco Cinema Controller and the Barco ICMP-X have each eight (8) opto-isolated outputs available. Four (4) of the outputs on the Cinema Controller are dedicated for TI. The other general purpose outputs can be controlled via software.

## About an output

The output can generate a falling edge, rising edge, toggle or continuous toggle.

- **Generate Falling Edge** – generate a falling edge on the external GPO port if the present state of the output is high. If the present state of the external GPO is low, no edge will be generated.
- **Generate Rising Edge** – generate a rising edge on the external GPO port if the present state of the output is low. If the present state of the external GPO is high, no edge will be generated.
- **Generate Toggle** – generate a toggle on the external GPO port. If the present state of the output is low, a rising edge will be generated, followed by a falling edge. If the present state of the output is high, a falling edge will be generated, followed by a rising edge. Pulse width = 20 milliseconds.
- **Generate Continuous Toggle** - This command will generate a continuous toggle of the external GPO port. This toggle will continue until a *Generate Falling Edge*, *Generate Rising Edge*, or *Generate Toggle* command is received. The rate of toggle is 24 Hz. .

## Output transistor

- Maximum output driving voltage :  $V_{max} = 24 V$
- Maximum current :  $I_{max} = 30 mA$
- Maximum power dissipation : 120 mW

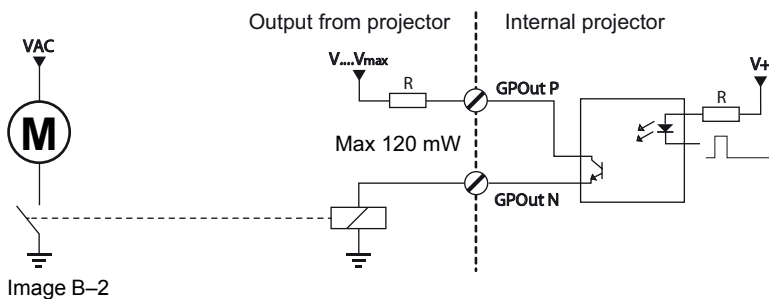

Image B-2



When the GPO driver inside the projector becomes powerless the GPO state changes to the default state. The default GPO state depends on the external system connected with the GPO port (pull-up or pull-down circuitry).

## GPIO and projector ECO mode

The Freya projector is equipped with an “ECO” mode, in which a minimum of features are available. Entering or leaving ECO mode can be done with GPIO of the Cinema Controller via a predefined Macro (not editable). However, this cannot be done with the GPIO of the ICMP-X.

The GPO signals of the ICMP will return to their default output level when the projector is switched to ECO mode. This could generate unexpected "Falling Edge" triggers at the output pins. Also when awakening the projector (from ECO mode to READY mode) the GPO signals of the ICMP may generate unexpected "Rising Edge" events.

## GPO and projector switching On or Off

The GPO signals of the Cinema Controller and ICMP will return to their default output level when the projector is switched to OFF. This could generate unexpected "Falling Edge" triggers at the output pins. Also during power-on the GPO signals may generate unexpected "Rising Edge" events.

# B.2 Pin configurations of the communication ports

## Ethernet port

			10/100 Base-T — RJ45 port	1000 Base-T — RJ45 port
Pin	Pair	Color	Description	Description
1	3	white/green	TXD+	TX0+
2	3	green	TXD-	TX0-

			10/100 Base-T — RJ45 port	1000 Base-T — RJ45 port
Pin	Pair	Color	Description	Description
3	2	white/orange	RXD+	RX0+
4	1	blue	—	TX1+
5	1	white/blue	—	TX1-
6	2	orange	RXD-	RX0-
7	4	white/brown	—	Rx1+
8	4	brown	—	RX1-

**General Purpose Input (GPI):**

GPI 1-4		
RJ-45 pin nr	Definition	GPI Name
1	GPI 1 P	GPI 1, reserved for 3D L/R input reference
2	GPI 1 N	
3	GPI 2 P	GPI 2, reserved for 3D L/R display reference
4	GPI 2 N	
5	GPI 3 P	GPI 3, reserved for power control
6	GPI 3 N	
7	GPI 4 P	GPI 4 (free)
8	GPI 4 N	

GPI 5-8		
RJ-45 pin nr	Definition	GPI Name
1	GPI 5 P	GPI 5 (free)
2	GPI 5 N	
3	GPI 6 P	GPI 6 (free)
4	GPI 6 N	
5	GPI 7 P	GPI 7 (free)
6	GPI 7 N	
7	GPI 8 P	GPI 8 (free)
8	GPI 8 N	

**General Purpose Output (GPO):**

GPO 1-4		
RJ-45 pin nr	Definition	GPI Name
1	GPO 1 P	GPO 1, reserved for 3D L/R output reference
2	GPO 1 N	
3	GPO 2 P	GPO 2, reserved
4	GPO 2 N	
5	GPO 3 P	GPO 3, reserved
6	GPO 3 N	
7	GPO 4 P	GPO 4 (free)



<b>GPO 1-4</b>		
<b>RJ-45 pin nr</b>	<b>Definition</b>	<b>GPI Name</b>
8	GPO 4 N	

<b>GPO 5-8</b>		
<b>RJ-45 pin nr</b>	<b>Definition</b>	<b>GPI Name</b>
1	GPO 5 P	GPO 5 (free)
2	GPO 5 N	
3	GPO 6 P	GPO 6 (free)
4	GPO 6 N	
5	GPO 7 P	GPO 7 (free)
6	GPO 7 N	
7	GPO 8 P	GPO 8 (free)
8	GPO 8 N	

### Peripheral Port

<b>Pin</b>	<b>Name</b>
1	+5V
2	SCL
3	SDA
4	+24V
5	GND

### 3D connector

<b>Pin</b>	<b>Name</b>	<b>Pin</b>	<b>Name</b>
1	+12V	9	+12V
2	Grnd	10	3D Input Reference -
3	Grnd	11	3D Display Reference +
4	RS232 RX	12	3D Display Reference -
5	RS232 TX	13	CONN_3D MODE -
6	CONN_3D_MODE +	14	CONN_SYNC -
7	CONN_SYNC +	15	-
8	3D Input Reference +		

## B.3 Pin configurations of the ICMP-X communication ports

### RJ-45 pin configuration

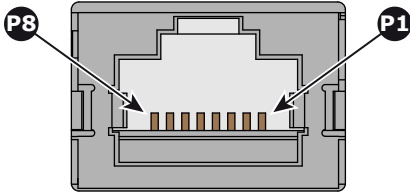

Image B-3

### Audio Channels:

AUDIO-AES 1-8		
Audio channel	AES pair	RJ-45 pin
1, 2	1 +	1
	1 -	2
3, 4	2 +	3
	2 -	6
5, 6	3 +	4
	3 -	5
7, 8	4 +	7
	4 -	8

AUDIO-AES 9-16		
Audio channel	AES pair	RJ-45 pin
9, 10	5 +	1
	5 -	2
11, 12	6 +	3
	6 -	6
13, 14	7 +	4
	7 -	5
15, 16	8 +	7
	8 -	8

### General Purpose Output:

GPO 1-4	
Definition	RJ-45 pin
EXT_GPOUT_1_P	1
EXT_GPOUT_1_N	2
EXT_GPOUT_2_P	3
EXT_GPOUT_2_N	4

<b>GPO 1-4</b>	
<b>Definition</b>	<b>RJ-45 pin</b>
EXT_GPOUT_3_P	5
EXT_GPOUT_3_N	6
EXT_GPOUT_4_P	7
EXT_GPOUT_4_N	8

<b>GPO 5-8</b>	
<b>Definition</b>	<b>RJ-45 pin</b>
EXT_GPOUT_5_P	1
EXT_GPOUT_5_N	2
EXT_GPOUT_6_P	3
EXT_GPOUT_6_N	4
EXT_GPOUT_7_P	5
EXT_GPOUT_7_N	6
EXT_GPOUT_8_P	7
EXT_GPOUT_8_N	8

**General Purpose Input:**

<b>GPI 1-4</b>	
<b>Definition</b>	<b>RJ-45 pin</b>
EXT_GPIN_1_P	1
EXT_GPIN_1_N	2
EXT_GPIN_2_P	3
EXT_GPIN_2_N	4
EXT_GPIN_3_P	5
EXT_GPIN_3_N	6
EXT_GPIN_4_P	7
EXT_GPIN_4_N	8

<b>GPI 5-8</b>	
<b>Definition</b>	<b>RJ-45 pin</b>
EXT_GPIN_5_P	1
EXT_GPIN_5_N	2
EXT_GPIN_6_P	3
EXT_GPIN_6_N	4
EXT_GPIN_7_P	5

<b>GPI 5-8</b>	
<b>Definition</b>	<b>RJ-45 pin</b>
EXT_GPIN_7_N	6
EXT_GPIN_8_P	7
EXT_GPIN_8_N	8

### About 568A and 568B on an Ethernet connector RJ-45

TIA/EIA-568A and -568B are two standards for connecting Category 3 and Category 5 wire to connectors. Both are appropriate for high speed data, though 568B is somewhat more common for installed wiring and 568A is more common in jumpers. There is no performance advantage either way. The only real difference between the two is the order in which the pairs are used (orange and green).

Hold a cable as if to plug it into a wall jack, the locking tab down (contacts facing you). The contacts are numbered 1-8 from left to right. Here's what you will see:

<b>RJ-45 Pin Number (Left &gt;Right copper side)</b>	<b>568A</b>		<b>568B</b>		<b>AES -1-8</b>
1	White/Green			White/Orange	AES 1&2 +plus
2	Green			Orange	AES 1&2 +minus
3	White/Orange			White/Green	AES 3&4 +plus
4	Blue			Blue	AES 5&6 +minus
5	White/Blue			White/Blue	AES 5&6 +plus
6	Orange			Green	AES 3&4 +minus
7	White/Brown			White/Brown	AES 7&8 +plus
8	Brown			Brown	AES 7&8 +minus

568A and 568B may be used interchangeably in a system SO LONG AS both ends of a given cable are terminated the same way.

568A + 568B wiring is a crossover cable.

568A + 568A wiring is a straight cable.

568B + 568B wiring is a straight cable.

The mapping of the channels is done according to the Ethernet wiring scheme and gives us 100 Ohm per pair.

## B.4 Pin configurations of the inputs

### DVI-D

<b>DVI IN A &amp; B</b>							
1	RX2-	7	DDC Data	13	nc	19	RX0 Shield
2	RX2+	8	nc	14	+5V	20	nc
3	RX2 Shield	9	RX1-	15	GND	21	nc
4	nc	10	RX1+	16	Hot Plug Detect	22	TMDS Clock Shield

<b>DVI IN A &amp; B</b>							
5	nc	11	RX1 Shield	17	RX0-	23	TMDS RXC+
6	DDC Clock	12	nc	18	RX0+	24	TMDS RXC-



# Regulatory information

# C

C.1	Product compliance .....	384
C.2	Taiwan RoHS compliance.....	385
C.3	China RoHS compliance .....	386
C.4	Turkey RoHS compliance.....	387
C.5	Disposal information .....	387
C.6	Hazards .....	387
C.7	Production address.....	388
C.8	Contact information.....	388
C.9	Download Product Manual .....	388

## C.1 Product compliance

### EurAsian Conformity (EAC)



This product complies with the Safety of Low-Voltage Equipment (LVE Technical Regulation 004/2011, CU TR 004/2011) and the Electromagnetic Compatibility of Technical Products (EMC Technical regulation, CU TR 020/2011)

### Federal Communications Commission (FCC Statement)

This equipment has been tested and found to comply with the limits for a class A digital device, pursuant to Part 15 of the FCC rules. These limits are designed to provide reasonable protection against harmful interference when the equipment is operated in a commercial environment. This equipment generates, uses, and can radiate radio frequency energy and, if not installed and used in accordance with the instruction manual, may cause harmful interference to radio communications. Operation of this equipment in a residential area may cause harmful interference, in which case the user will be responsible for correcting any interference at his own expense

Changes or modifications not expressly approved by the party responsible for compliance could void the user's authority to operate the equipment

FCC responsible: Barco Inc.  
3059 Premiere Parkway Suite 400  
30097 Duluth GA, United States  
Tel: +1 678 475 8000

### EMC notices

#### EN55032/CISPR32 Class A MME (MultiMedia Equipment)

**Warning :** This equipment is compliant with Class A of CISPR 32. In a residential environment this equipment may cause radio interference.

#### GB/T 9254 A級ITE(信息技术设备)

**警告：**此為A級產品。在生活環境中，該產品可能會造成無線電干擾。在這種情況下，可能需要用戶對干擾採取切實可行的措施。

#### BSMI Taiwan Class A statement:

**警告使用者：**此為甲類資訊技術設備，於居住環境中使用，可能會造成射頻擾動，在此情況下，使用者會被要求採取某些適當的對策。

### BSMI Reporting Obligor Information / 報驗義務人資訊

- 一、 商品在國內產製時，為商品之產製者或輸出者。  
但商品委託他人產製，並以在國內有住所或營業所之委託者名義，於國內銷售或輸出時，為委託者。
- 二、 商品在國外產製時，為商品之輸入者。  
但商品委託他人輸入，並以在國內有住所或營業所之委託者名義，於國內銷售時，為委託者。
- 三、 商品之產製者、輸出者、委託產製或委託輸出入者不明或無法追查時，為銷售者。  
前項所稱產製者，包括具有下列情形之一者：
  - 一、 組裝者：商品由個別零組件以組裝銷售。
  - 二、 修改者：符合檢驗規定之商品於進入市場前，為銷售目的而修改。



## C.2 Taiwan RoHS compliance

### 限用物質含有情況標示聲明書 (Declaration of the Presence Condition of the Restricted Substances Marking)

設備名稱：數位電影投影機，型號(型式)：SP4K-12C Equipment name: Digital Cinema Projector, Type designation: SP4K-12C						
單元 Unit	限用物質及其化學符號 Restricted substances and its chemical symbols					
	鉛 Lead (Pb)	汞 Mercury (Hg)	鎘 Cadmium (Cd)	六價鉻 Hexavalent chromium (Cr6+)	多溴聯苯 Polybromi- nated biphenyls (PBB)	多溴二苯醚 Polybromi- nated diphenyl ethers (PBDE)
印製電路板配件 Printed Circuit Assemblies	—	○	—	○	○	○
外接電(線)纜 External Cables	—	○	○	○	○	○
內部線路 Internal wiring	—	○	○	○	○	○
鏡頭支架 Lens holder	—	○	○	○	○	○
光學鏡頭 Optical lenses	—	○	○	○	○	○
鐳射 Laser	—	○	○	○	○	○
螺帽, 螺釘(栓), 螺旋(釘), 墊圈, 緊固件 Nuts, bolts, screws, washers, fasteners	—	○	○	○	○	○
電源供應器 Power Supply Unit	—	○	○	○	○	○
風扇 Fan	—	○	○	○	○	○
泵 Pump	—	○	○	○	○	○

備考1. “超出0.1 wt %”及“超出0.01 wt %”係指限用物質之百分比含量超出百分比含量基準值。  
Note 1 : “Exceeding 0.1 wt %” and “exceeding 0.01 wt %” indicate that the percentage content of the restricted substance exceeds the reference percentage value of presence condition.

備考2. “○”係指該項限用物質之百分比含量未超出百分比含量基準值。  
Note 2 : “○” indicates that the percentage content of the restricted substance does not exceed the percentage of reference value of presence.

備考3. “—”係指該項限用物質為排除項目。  
Note 3 : The “—” indicates that the restricted substance corresponds to the exemption.

## C.3 China RoHS compliance

### 中国大陆 RoHS (Chinese Mainland RoHS)

根据中国大陆《电器电子产品有害物质限制使用管理办法》（也称为中国大陆RoHS），以下部分列出了Barco产品中可能包含的有毒和/或有害物质的名称和含量。中国大陆RoHS指令包含在中国信息产业部MCV标准：“电子信息产品中有毒物质的限量要求”中。

According to the “Management Methods for the Restriction of the Use of Hazardous Substances in Electrical and Electronic Products” (Also called RoHS of Chinese Mainland), the table below lists the names and contents of toxic and/or hazardous substances that Barco’s product may contain. The RoHS of Chinese Mainland is included in the MCV standard of the Ministry of Information Industry of China, in the section “Limit Requirements of toxic substances in Electronic Information Products”.

零件项目(名称) Component Name	有毒有害物质或元素 Hazardous Substances or Elements					
	铅 (Pb)	汞 (Hg)	镉 (Cd)	六价铬 (Cr6+)	多溴联苯 (PBB)	多溴二苯醚 (PBDE)
印制电路配件 Printed Circuit Assemblies	X	O	X	O	O	O
外接电(线)缆 External cables	X	O	O	O	O	O
内部线路 Internal wiring	X	O	O	O	O	O
镜头支架 Lens holder	X	O	O	O	O	O
光学镜头 Optical lenses	X	O	O	O	O	O
激光发生器 Laser	X	O	O	O	O	O
螺帽,螺钉(栓),螺旋(钉),垫圈,紧固件 Nuts, bolts, screws, washers, fasteners	X	O	O	O	O	O
电源供应器 Power Supply Unit	X	O	O	O	O	O
风扇 Fan	X	O	O	O	O	O
泵 Pump	X	O	O	O	O	O

本表格依据SJ/T 11364的规定编制

This table is prepared in accordance with the provisions of SJ/T 11364.

O: 表示该有毒有害物质在该部件所有均质材料中的含量均在 GB/T 26572 标准规定的限量要求以下。

O: Indicates that this toxic or hazardous substance contained in all of the homogeneous materials for this part is below the limit requirement in GB/T 26572.

X: 表示该有毒有害物质至少在该部件的某一均质材料中的含量超出 GB/T 26572 标准规定的限量要求。

X: Indicates that this toxic or hazardous substance contained in at least one of the homogeneous materials used for this part is above the limit requirement in GB/T 26572.



在中国大陆销售的相应电子信息产品（EIP）都必须遵照中国大陆《电子电气产品有害物质限制使用标识要求》标准贴上环保使用期限（EFUP）标签。Barco产品所采用的EFUP标签（请参阅实例，徽标内部的编号使用于指定产品）基于中国大陆的《电子信息产品环保使用期限通则》标准。

All Electronic Information Products (EIP) that are sold within Chinese Mainland must comply with the “Marking for the restriction of the use of hazardous substances in electrical and electronic product” of Chinese Mainland, marked with the Environmental Friendly Use Period (EFUP) logo. The number inside the EFUP logo that Barco uses (please refer to the photo) is based on the “General guidelines of environment-friendly use period of electronic information products” of Chinese Mainland.

## C.4 Turkey RoHS compliance

### Turkey RoHS compliance



Türkiye Cumhuriyeti: AEEE Yönetmeliğine Uygundur.  
[Republic of Turkey: In conformity with the WEEE Regulation]

## C.5 Disposal information

### Disposal Information



Waste Electrical and Electronic Equipment (WEEE)

This symbol on the product indicates that, under the European Directive 2012/19/EU governing waste from electrical and electronic equipment, this product must not be disposed of with other municipal waste. Please dispose of your waste equipment by handing it over to a designated collection point for the recycling of waste electrical and electronic equipment. To prevent possible harm to the environment or human health from uncontrolled waste disposal, please separate these items from other types of waste and recycle them responsibly to promote the sustainable reuse of material resources.

For more information about recycling of this product, please contact your local city office or your municipal waste disposal service. For details, please visit the Barco website at: <http://www.barco.com/AboutBarco/weee>

### Disposal of batteries in the product



This product contains batteries covered by the Directive 2006/66/EC which must be collected and disposed of separately from municipal waste.

If the battery contains more than the specified values of lead (Pb), mercury (Hg) or cadmium (Cd), these chemical symbols will appear below the crossed-out wheeled bin symbol.

By participating in separate collection of batteries, you will help to ensure proper disposal and to prevent potential negative effects on the environment and human health.

## C.6 Hazards

### Safety notice Sodium Carbonate (Na<sub>2</sub>CO<sub>3</sub>)

According to the Safety Data Sheet (SDS), Sodium Carbonate could cause serious eye irritation.

### Safety Data Sheets for Hazardous Chemicals

For safe handling information on chemical products, consult the Safety Data Sheet (SDS). SDSs are available upon request via [safetydatasheets@barco.com](mailto:safetydatasheets@barco.com).

## C.7 Production address

### Factories

**Barco NV (BELGIUM)**

President Kennedypark 35, B-8500 Kortrijk

**Barco Visual (Beijing) Electronics Co. Ltd.****巴可伟视（北京）电子有限公司**

No.16 Changsheng Road, Changping District, 102200, Beijing, P.R.C

北京市昌平区中关村科技园区昌平园昌盛路16号 邮政编码：102200

### Made in information

The made in country is indicated on the product ID label on the product itself.

### Production date

The month and year of production is indicated on the product ID label on the product itself.

## C.8 Contact information

### Barco contact information

Registered office address: President Kennedypark 35, 8500 Kortrijk, Belgium

Contact address: Beneluxpark 21, 8500 Kortrijk, Belgium

### Importers contact information

To find your local importer, contact Barco directly or one of Barco's regional offices via the contact information given on Barco's web site, [www.barco.com](http://www.barco.com).

## C.9 Download Product Manual

### Download Product Manual

Product manuals and documentation are available online at [www.barco.com/td](http://www.barco.com/td).

Registration may be required; follow the instructions given on the website.

**IMPORTANT!** Read Installation Instructions before connecting equipment to the mains power supply.

# Glossary

## **3G-SDI**

Serial Digital Interface (SDI) is a serial link standardized by ITU-R BT.656 and the Society of Motion Picture and Television Engineers (SMPTE). SDI transmits uncompressed digital video over 75-ohm coaxial cable within studios, and is seen on most professional video infrastructure equipment. The first revision of the standard, SMPTE 259M, was defined to carry digital representation of analog video such as NTSC and PAL over a serial interface and is more popularly known as standard-definition (SD) SDI. The data rate required to transmit SD SDI is 270 Mbps. With the advent of high-definition (HD) video standards such as 1080i and 720p, the interface was scaled to handle higher data rates of 1.485 Gbps. The 1.485-Gbps serial interface is commonly called the HD SDI interface and is defined by SMPTE 292M, using the same 75-ohm coaxial cable. Studios and other video production facilities have invested heavily on the hardware infrastructure for coaxial cable and have a vested interest in extending the life of their infrastructure. Fortunately, SMPTE recently ratified a new standard called SMPTE 424M that doubles the SDI data rates to 2.97 Gbps using the same 75-ohm coaxial cable. This new standard, also called 3-Gbps (3G)-SDI, enables higher resolution of picture quality required for 1080p and digital cinema.

## **Default Gateway**

A router that serves as an entry point into and exit point out of a network. For example, a local network (LAN) may need a gateway to connect it to a wide area network (WAN) or to the Internet.

## **DHCP**

Dynamic host configuration protocol. DHCP is a communications protocol that lets network administrators manage centrally and automate the assignment of IP addresses in an organization's network. Using the Internet Protocol, each machine that can connect to the Internet needs a unique IP address. When an organization sets up its computer users with a connection to the Internet, an IP address must be assigned to each machine. Without DHCP, the IP address must be entered manually at each computer and, if computers move to another location in another part of the network, a new IP address must be entered. DHCP lets a network administrator supervise and distribute IP addresses from a central point and automatically sends a new IP address when a computer is plugged into a different place in the network.

## **DNS server**

Computers, Projectors, Touch panels connected to a network are referenced by their IP address. The only problem is that remembering IP addresses is not easy. If you need to use hundreds of addresses then it will become impossible to remember them. This is why domain names are created. Internet names (domain and host names) are just aliases to these IP addresses. When you use an Internet address it is automatically translated to an IP address. In fact a program or device that translates those Internet names to IP addresses is called a DNS Server.

**HD**

Hazard Distance (HD) is the distance measured from the projection lens at which the intensity or the energy per surface unit becomes lower than the applicable exposure limit on the cornea or on the skin. The light beam is considered (to be) unsafe for exposure if the distance from a person to the light source is less than the HD.

**HDMI**

HDMI (High-Definition Multimedia Interface) is a compact audio/video interface for transferring uncompressed video data and compressed/uncompressed digital audio data from a HDMI-compliant device ("the source device") to a compatible computer monitor, video projector, digital television, or digital audio device. HDMI is a digital replacement for existing analog video standards.

**Host name**

This is the name that will be returned, along with the IP address in response to the UDP broadcast query for projectors/touch panels.

**IP**

Internet Protocol. The network layer of TCP/IP. Required for communication with the internet.

**LSC file**

Light sensor calibration file

**LSC**

Light sensor calibration

**NTP**

Network Time Protocol

**SPL**

Show play list

**Subnet mask**

A number that is used to identify a subnetwork so that IP addresses can be shared on a local area network.

**UDP**

User Datagram Protocol

## List of tools

Allen wrench 4 mm  
Authorization pin code  
Bucket with hot water  
Clean cotton cloth  
Clean micro fiber lens cleaning cloth (e.g. Toraysee® cloth(s))  
Compressed air  
Lens cleaner (e.g. ZEISS lens cleaner, Purosol™ or other water based lens cleaner products)  
Photospectrometer  
Sodium carbonate, 30 gram (handful) per liter hot water  
Spectroradiometer  
Vacuum cleaner with soft brush suction nuzzle.  
Web Communicator





# Index

## Numbers/Symbols

3D  
  Configuration 127  
3D file 127  
  Activate 138  
  Backup 142  
  Configuration 129, 131–134, 136–144  
  Create 129  
  Delete 143–144  
  Edit 137  
  Editor 131–134, 136  
  Export 141  
  Import 140  
  Rename 139

## A

Access level 60  
Account  
  Modify 56  
Activate  
  3D file 138  
  ECO mode 81  
  Input file 152  
  Lens 115  
  Lens file 122  
  LSC file 194  
  Macro 70  
  Macros 97  
  PCF 107  
  SCC file 215  
  Screen file 169  
  Test patterns 77, 177  
Add  
  Devices 230  
Address  
  Made in 388  
  Production 388  
Administrator 60  
  Password 54  
Analysis 315

  Diagnostic package 317  
    Self test 316  
Application appearance 56  
Audio channel 274  
  Modify 275  
Authorization  
  Security warning  
    Clear 345  
Automation  
  Media server 230  
Automation settings  
  Export 250  
  Import 251

## B

Backup 325  
  3D file 142  
  Full system 325  
  ICMP settings 328  
  Input file 156  
  Lens file 125  
  Macros 103  
  PCF 111  
  Screen file 173  
  Test patterns 182  
Batteries  
  Disposal 387  
Battery  
  Disposal 387

## C

Calibrate  
  Lens 116  
Calibration  
  Light sensor 192  
certificate  
  Add 258  
Check  
  Dust filter 340–342  
Cleaning

- Exterior 345
- Filters 342
- Filters (wet) 343
- Lens 344
- CLO mode 197
- Clock 186
- Close
  - Dowser 73
- Color calibration
  - about 207
  - Light source 202
  - White point calibration 202
- Process overview 202
- Spatial color calibration file
  - activate 215
  - create 217
  - Delete 216
  - Delete several files 220
  - export 219
  - import 219
  - rename 215
- White Point 204
- White point calibration 202
- Commands
  - Add 91
  - Delete 93
  - Edit 93
  - Macros 91, 93–94
  - Order 94
- Communication protocol (HTTPS)
  - Invalid certificate issue 50
  - Overview 50
- Compliance
  - Product 384
- Configuration
  - 3D file 131, 139–144
  - 3D files 129, 131–134, 136–138
  - certificate
    - Add 258
  - Certificate 255
  - Color calibration 201
    - Light source 202
  - GPI 221
  - GPIO 221
  - GPO 221
  - ICMP-X 38
  - Input file 147, 149–150, 153–156, 158, 171
  - Input files 146, 151–152
  - Lens file 121–122
  - License 255
    - Add 256
    - Delete 256
  - Light output 191
  - Macros 88–90, 95–97, 99–105
  - Media server 263
    - Audio channel 274
    - Content settings 264
    - Immersive sound settings 273
    - Player 270
    - Scheduler settings 271
  - Media server automation 229–230
    - Groups 233
    - Input cues 237
    - System cues 237
    - User cues 237
- Overview 66
- Projector 87
  - 3D file 127
  - Image orientation 188
  - Image Orientation 188
  - Input file 145
  - Internal clock 185
  - Lens position 118
  - Lens selection 114
  - PCF 105
  - Screen file 159
  - Test patterns 176
- Projector automation 221
- Projector color 207
- Projector registration
  - Add 260
- Screen file 161, 172–175
- Screen files 160, 162–163, 167–169
- Spatial color calibration 214
- System access 277
  - Manage users 285
  - Marriage pin code 290
  - Multi projectors 298
  - Network configuration 278
  - SNMP 294
- Test patterns 176–177, 184
- Configuration (general)
  - Process overview 65
- Connectivity 31
- Contact address 388
- Contact information 388
- Content settings
  - Create device 264
  - Delete device 269
  - Edit device 267
  - Modify device 267
  - Overview 264
- Control
  - Macro 70
  - Projector 69
    - Dowser 71
    - Lens 71
    - Light 71
  - Macros control 70
  - Power 80
  - Reboot 80
  - Scheduler 83–84
  - Test patterns 76
  - Test patterns 76, 78
- Control key shortcut
  - Lens 75
- Control menu
  - Test patterns 77
- Corrected Colors
  - Verify 211
- create
  - SCC file 217
- Create
  - 3D file 129
  - Input file 146
  - Lens file 119

- Light sensor calibration file 193
- LSC file 193
- Macros 89
- PCF 106
- Screen file 160
- Create from active state
  - Macros 90
- Cues
  - Input cues 237
  - System cues 237
  - User cues 237

## D

- Dark screen
  - Detection 273
- Dashboard
  - Web Communicator 59
- Date
  - Production 388
- Daylight Saving Time 186
- Deactivate
  - Test patterns 78, 177
- Delete
  - 3D file 143–144
  - Input file 158
  - Lens file 126–127
  - LSC file 195
  - Macros 104–105
  - PCF 113
  - SCC file 216
  - Screen file 174–175
  - Several SCC files 220
  - Test patterns 184
- Devices
  - Media server 230
- Diagnostic package 317
  - Read out 318
- Diagnostics
  - Analysis 315
    - Diagnostic package 317
    - Self test 316
  - Monitoring 307
    - Metrics 312
    - Notifications 309
    - RAID information 309
    - System information 308
- Disposal 387
  - Battery 387
- Disposal of batteries 387
- Download
  - Product manual 388
- Dowser 71
  - Open/Close 73
- Drying
  - Filters 343
- DST
  - Daylight Saving Time 186
- Dust filter
  - Front
    - Replace 340
  - LDM
    - Replace 342

- Rear
  - Replace 341

## E

- ECO mode 80–81
- Edit
  - 3D file 137
  - Commands 93
  - Input file 151
  - Lens file 121
  - LSC file 195
  - Macros 90, 95
  - Screen file 168
- Editor
  - 3D file 131–134, 136
  - Input file 147, 149–150
  - Screen file 161–163, 167
- Enclosed projection 24
- Environmental information
  - Disposal 387
  - RoHS compliance 386
    - Taiwan 385
    - Turkey 387
- EurAsian Conformity (EAC) 384
- Exclusion zone 15
- Export
  - 3D file 141
  - Input file 155
  - Lens file 124
  - Macros 102
  - PCF 110
  - SCC file 219
  - Screen file 172
  - Test patterns 181
- Exterior
  - Cleaning 345

## F

- Factory restore 330
- File system
  - Check 334
- Filters
  - Cleaning 342
  - Cleaning (wet) 343
- Focus
  - Lens 74
- Front cover
  - Mounting 350, 355
  - Removal 348, 352
- Front dust filter
  - Replace 340

## G

- General considerations 14
- General Purpose I/O 374
- Getting started 27
- GPI
  - Allocate a macro 222
- GPIO 374

- Configuration 221
- GPI
  - Allocate a macro 222
- GPO Event 224
- GPO Status
  - Change 226
- Group
  - Delete 236
  - Edit 235
  - Media server automation 233
  - New 233
  - Rename 235
- Groups
  - Export 250
  - Import 251
- GUI
  - Overview 46

**H**

- Hazard Distance 22, 24
  - Modifying optics 26
- Hazardous Chemicals 19, 387
- Hazards 387
- HDD
  - Remove 41
    - ICMP 42
  - Status LEDs 39
  - Troubleshooting 39
- HDMI 2.0
  - Specifications 368
- High Brightness precautions 22
- HTTPS 50

**I**

- ICMP-X 37
  - configuration 38
  - Reboot 82
  - Reset 44
- Image orientation
  - Settings 188
- Image Orientation
  - Settings 188
- Immersive sound settings 273
- Import
  - 3D file 140
  - Input file 154
  - Lens file 123
  - Macros 101
  - PCF 109
  - Screen file 172
  - Test patterns 180
- Importer 388
- Input cue
  - Automation cues 237
- Input cues
  - Commands 242
  - Devices 242
  - Edit action 250
  - Export 250
  - Import 251

- New 247
- Input file 145
  - Activate 152
  - Backup 156
  - Configuration 146–147, 149–156, 158, 171
  - Create 146
  - Delete 158
  - Edit 151
  - Editor 147, 149–150
  - Export 155
  - Import 154
  - Rename 153, 171
- Internal clock 38, 186
  - Settings 185

**L**

- Language
  - Modify 57
- Laser Bank 335
  - Deactivate/activate notifications 336
  - Status 335
- Laser management 335
- Laser Management
  - Deactivate/activate notifications 336
- LDM dust filter
  - Replace 342
- Lens 71
  - Activate 115
  - Calibrate 116
  - Cleaning 344
  - Control key shortcut 75
  - Focus 74
  - Position 118
  - Select 114
  - Shift 74
  - Zoom 74
- Lens file 118
  - Activate 122
  - Backup 125
  - Configuration 121–122
  - Create 119
  - Delete 126–127
  - Edit 121
  - Export 124
  - Import 123
  - Rename 122
- Lens position file 119
- License
  - Add 256
  - Delete 256
  - Open source 61
- Light 71
- Light output
  - Configuration 191
  - Light sensor
    - Calibration file 193–196
- Light output mode
  - Constant Light Output (CLO) 197
  - Normal 197
- Light sensor
  - Calibration 192
- Light source

- Color calibration 204
- White point calibration 202
- Light Source
  - on-off 72
  - Power 72

- Linking to preset
  - Macros 99

- Logout
  - Web Communicator 55

- LSC file
  - Activate 194
  - Create 193
  - Delete 195
  - Editing 195
  - Rename 196

## M

### Macro

- Activate 70
- Control 70
- Projector 70

- Macro control 70
  - Overview 70

### Macros 88

- Activate 97
- Backup 103
- Commands 90–91, 93–94
- Configuration 89–90, 95–97, 99–105
- Create 89
- Create from active state 90
- Delete 104–105
- Edit 90, 95
- Editor 90
- Export 102
- Import 101
- Linking to preset 99
- Rename 96
- Save as cue 99
- Unlink from preset 100

### Maintenance 321, 339

- 3 month 338
- Backup 325
- Backup and restore
  - Full system 325
  - ICMP settings 328
- Laser Bank
  - Status 335
- Laser management 335
- Laser Management
  - Deactivate/activate notifications 336
- Raid storage 332
  - File system 334
  - Initialize 333
  - Status 332
- Restore 325
  - Factory 330
- Service mode 325
- Software
  - Update 322

- Maintenance program 337
  - 1 Month 338

### Manage users

- About 285

- Create
  - Delete 290
  - Modify 288
  - New 287

- Menu access control
  - Editor 285

### Marriage

- Pin code
  - About 290
  - Delete 292
  - Modify 293
  - New 291

### Marros

- Configuration 88

### MCGD files 207

### Media server

- Audio channel 274
  - About 274
  - Modify 275
- Configuration 263
- Content settings 264
  - Create device 264
  - Delete device 269
  - Edit device 267
  - Modify device 267
  - Overview 264
- Immersive sound settings 273

### Player 270

- About settings 270
- Modify settings 270

### Reboot 82

- Scheduler settings 271
  - About 271
  - Modify 272

### Media server automation

- Automation settings
  - Export 250
  - Import 251
- Commands 242
- Devices 230, 242
  - Add 230
  - Delete 232
  - Export 233
  - Import 233
  - Update 231

### Groups 233

- Delete 236
- Edit 235
- Export 236, 250
- import 251
- Import 236
- New 233
- Rename 235

### Input cues 237

- Edit action 250
- Export 250
- Import 251
- New 247

### System cues 237

- Add actions 245
- Export 250
- Import 251

### User cues 237

- Delete 244
- Edit 239, 243
- Export 250
- Import 251
- Rename 243
- Menu tree 62
- Modifying
  - Account 56
  - Language 57
  - Password 56
  - Theme 57
  - Time format 57
- Monitoring
  - Diagnostics 307
  - Notifications 309
  - RAID information 309
  - System information 308
- Multi projectors 298
  - Linked CLO 302
    - Adding slave 302
    - Deleting slave 304
    - Modifying slave 304
    - Verify secure connection 303
  - Linked ICMP 300
    - Adding slave 300
    - Deleting slave 302
    - Modifying slave 301
- Overview 298

## N

- Network configuration
  - Auditorium name 280
  - Domain 281
  - Host name 281
  - Network address
    - Automatic 282
    - Manually 282
  - Overview 278
- Network Time Protocol 38, 186
- Notice on optical radiation
  - Optical radiation 14
- Notice on safety 14
- Notifications 309
- NTP
  - Network Time Protocol 186

## O

- OFF mode 80
- Offset
  - Secure clock 186
- ON mode 80
- on-off
  - Light Source 72
  - Test pattern 73
- Open
  - Dowser 73
- Open source
  - License 61
- Operation in 24/7 Mode 33
- Order

- Commands 94
- Overview
  - Process 66
  - User Interface 46

## P

- Password
  - Administrator 54
  - Modify 56
- PCF 105
  - Activate 107
  - Backup 111
  - Create 106
  - Delete 113
  - Export 110
  - Import 109
  - Rename 108
- Picture 159
- Pin code
  - Marriage 290
    - About 290
    - Create new 291
    - Delete 292
    - Modify 293
- Pin configuration
  - Communication ports 375
  - Inputs 380
- Pin configurations 373
  - ICMP-X 378
- Player
  - About settings 270
  - Modify settings 270
- Position
  - Lens 118
- Power
  - Control 80
  - ECO mode 81
  - Light Source 72
  - Mode 80–81
- Power Cycle
  - Power states 28
- Prerequisites
  - projector configuration 66
- Process
  - Overview 66
- Product safety labels 20
- Production
  - Address 388
  - Date 388
- Projector
  - 3D file 127, 129, 131–134, 136–144
  - Configuration 87
  - Dowser 71
    - Power 73
  - ECO mode 81
  - Image orientation 188
  - Image Orientation 188
  - Input file 145–147, 149–156, 158, 171
  - Internal clock 185–186
  - Lens 71
    - Control key shortcut 75
    - Focus 74

- Shift 74
- Zoom 74
- Lens file 121–122
- Lens position 118
- Lens selection 114
- Light 71
- Light Source
  - on-off 72
  - Power 72
- Macro 70
- Macros 88–90, 95–97, 99–105
- Macros control 70
  - Overview 70
- Mode 80
- PCF 105
- Power 80
- Reboot 82
- Scheduler 83–84
- Screen file 159–163, 167–169, 172–175
- Test pattern
  - on-off 73
- Test patterns 76–78, 176–177, 184
  - Assign to shortcut 178
  - Remove from shortcut 179
- Projector automation
  - GPI
    - Allocate a macro 222
  - GPO Event
    - Allocation 224
  - GPO Status
    - Change 226
- Projector color
  - MCGD file
    - Create 208
    - Delete 210
    - Edit 208
    - Export 209
    - Import 209
- Projector Color
  - Color calibration 207
- Projector configuration
  - Prerequisites 66
  - process overview 65
- Projector covers
  - With frame 351
  - Without frame 347
- Projector registration
  - Add 260

**R**

- RAID information 309
- Raid storage 332
  - File system
    - Check 334
  - Initialize 333
  - Status 332
- READY mode 80
- Rear cover
  - Mounting 349, 353
  - Remove 348, 352
- Rear dust filter
  - Replace 341

- Rear projection 24
- Reboot 80
  - Media server 82
  - Projector 82
- Registered office 388
- Regulatory information 383
- Removal
  - Front cover 348, 352
- Remove
  - HDD 41
  - ICMP 42
- Rename
  - 3D file 139
  - Input file 153, 171
  - Lens file 122
  - LSC file 196
  - Macros 96
  - PCF 108
  - SCC file 215
- Replace
  - Dust filter
    - Front 340
    - LDM 342
    - Rear 341
- Reset
  - ICMP-X 44
  - Password
    - Administrator 54
- Restore 325
  - Factory 330
  - Full system 325
  - ICMP settings 328
- Restricted access location 15
- RoHS
  - Taiwan 385

## S

- Safety 13
  - Battery explosion 18
  - Electrical shock 16
  - Fire hazard 17
  - Hazard Distance 22, 24
  - Hazardous Chemicals 19, 387
  - Important instructions 16
  - Personal injury 17
  - Projector damage 18
  - reinforcement frame 19
  - Safety Data Sheet (SDS) 19, 387
  - Servicing 18
- Safety Data Sheet (SDS) 19, 387
- Safety training 15
- Save as cue
  - Macros 99
- SCC file
  - Activate 215
  - create 217
  - Delete 216
  - Delete several files 220
  - Export 219
  - Import 219
  - Rename 215
- SCC files 214

- Scheduler 83
    - Add an automatic start or stop 84
    - Control 83
    - Remove an automatic start or stop 84
  - Scheduler settings
    - About 271
    - Modify 272
  - Screen file 159
    - Activate 169
    - Backup 173
    - Configuration 160–163, 167–169, 172–175
    - Create 160
    - Cropping (active area) 162
    - Delete 174–175
    - Edit 168
    - Editor 161–163, 167
    - Export 172
    - Import 172
    - Masking 167
    - Scaling 163
  - SDI
    - Specifications 365
  - Search 58
  - Secure clock 186
  - Select
    - Lens 114
  - Self test 316
  - Server secure clock 186
  - Service mode 325
  - Service Technician 60
  - Set
    - Date 186
    - Time 186
  - Shift
    - Lens 74
  - Show Manager 60
  - Signing out
    - Web Communicator 55
  - SNMP 294
    - Add
      - New receiver 296
    - Delete
      - Receiver 296
    - Modify IP
      - Receiver 297
    - New receiver
      - Add 296
    - Overview 294
    - Receiver
      - Delete 296
      - Modify IP 297
    - Resend interval
      - Modify 295
  - Software
    - Update 322
  - Spatial color
    - calibration 214
  - Spatial color calibration
    - about 214
  - Specifications 357
    - Freya 358
    - Freya MKII 360
    - Freya+ 362
    - HDMI 2.0 368
    - ICMP-X 364
    - SDI 365
  - Starting up
    - HTTPS communication protocol 50
    - Switching on 30
    - Web Communicator 49
  - Status LEDs 38
    - HDD 39
  - Switch
    - Power mode 81
  - Switching off
    - ECO mode 32
  - Switching on 30
  - System access 277
    - Manage users 285
      - About 285
      - Create 287
      - Delete 290
      - Menu access control editor 285
      - Modify 288
  - Marriage
    - Delete pin code 292
    - Modify pin code 293
    - New pin code 291
    - Pin code 290
  - Multi projectors 298
    - Linked CLO: Adding, modifying, verifying and deleting slave projector 302
    - Linked ICMP: Adding, modifying and deleting slave projector 300
    - Overview 298
  - Network configuration 278
    - Auditorium name 280
    - Domain 281
    - Host name 281
    - Network address 282
    - Overview 278
  - Pin code
    - Marriage 290
  - SNMP 294
    - Delete receiver 296
    - Modify IP 297
    - New receiver 296
    - Overview 294
    - Resend interval 295
  - System cue
    - Automation cues 237
  - System cues
    - Add actions 245
    - Commands 242
    - Devices 242
    - Export 250
    - Import 251
  - System information 308
  - System overview
    - Web Commander 34
    - Web communicator 34
- T**
- Test pattern
    - on-off 73
  - Test patterns



- Activate 77, 177
- Assign to shortcut 178
- Backup 182
- Configuration 176–177, 184
- Control 76
- Control menu 77
- Deactivate 78, 177
- Delete 184
- Export 181
- Import 180
- Remove from shortcut 179
- Theme
  - Modify 57
- Time format
  - Modify 57
- Time zone 186
- Turkey RoHS 387

## U

- Unlink from preset
  - Macros 100
- Usage 15
- User cue
  - Automation cues 237
- User cues
  - Commands 242
  - Delete 244
  - Devices 242
  - Edit 239, 243
  - Export 250
  - Import 251
  - Rename 243
- User definition 14
- User groups
  - Administrator 60
  - Service Technician 60
  - Show Manager 60
- User Interface
  - Overview 46
- User management 285
- User rights 60

## V

- Vacuum
  - Filters 342
- Verify
  - Corrected Colors 211

## W

- Washing
  - Filters 343
- Web Communicator
  - Dashboard 59
  - Graphical User Interface 45
  - GUI 45
  - Signing out 55
  - Starting up 49
- WEEE 387
- White point calibration

- White point tracking 202
- White point Calibration 204

## Z

- Zoom
  - Lens 74







R5910032 /03 | 2022-03-31

[www.barco.com](http://www.barco.com)